

Instituto Federal de Educação, Ciência e Tecnologia de Santa Catarina

Departamento Acadêmico de Eletrônica

Eletrônica de Potência



# Dimensionamento e Especificação de Semicondutores

Prof. Clovis Antonio Petry.

Florianópolis, março de 2026.

# Eletrônica de Potência

O material do curso está disponível em:

1. Moodle para os alunos matriculados na disciplina;
2. Página do professor;
3. Canal no youtube do professor.



<https://moodle.ifsc.edu.br>

ProfessorPetry  
Conhecimento para uma vida plena

PRINCIPAL PROJETO PUBLICAÇÕES CONTATO



**Bem vindo ao Website pessoal de Clovis Antonio Petry**

O objetivo desta página é a divulgação de informações sobre eletrônica, em especial eletrônica de potência. Todos os materiais disponibilizados podem ser livremente utilizados, desde que citados os autores. As disciplinas do semestre corrente podem ser acessadas clicando na imagem da esquerda abaixo. Material didático pode ser encontrado clicando na imagem da direita abaixo.

**Eventos**

**Outubro, 2020**  
**SNCT 2020**  
Semana Nacional de Ciência e Tecnologia 2020, Florianópolis, SC.  
[Acesse...](#)

**Setembro, 2020**  
**COBENGE 2020**  
XLVIII Congresso Brasileiro de Educação em Engenharia (COBENGE) e III Simpósio Internacional de Educação em Engenharia da ABENGE, Bento Gonçalves, RS. [Acesse...](#)



[www.ProfessorPetry.com.br](http://www.ProfessorPetry.com.br)



<https://www.youtube.com>

# Agenda

Esta aula está organizada em:

1. Especificação de semicondutores:
  1. Introdução;
  2. Exemplos de dimensionamento e especificação.
2. Cálculo térmico:
  1. Cálculo térmico aplicado a semicondutores.



# Motivação

O projeto térmico é essencial para o correto funcionamento dos circuitos eletrônicos.

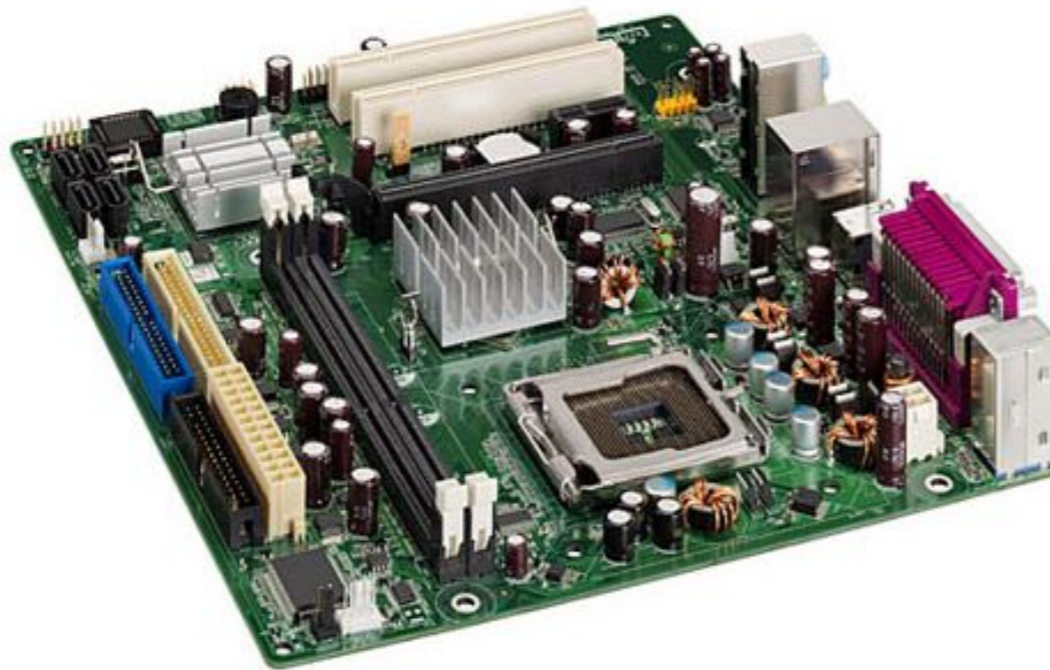

Fonte: imagens disponíveis na internet.

# Dimensionamento e Especificação de Semicondutores

## Exemplo 1:

- Considerando o circuito abaixo:
  - Tensão máxima fornecida pelo painel = 18 V;
  - Corrente máxima fornecida pelo painel = 200 mA;
  - Número de horas em média de insolação = 6 h.

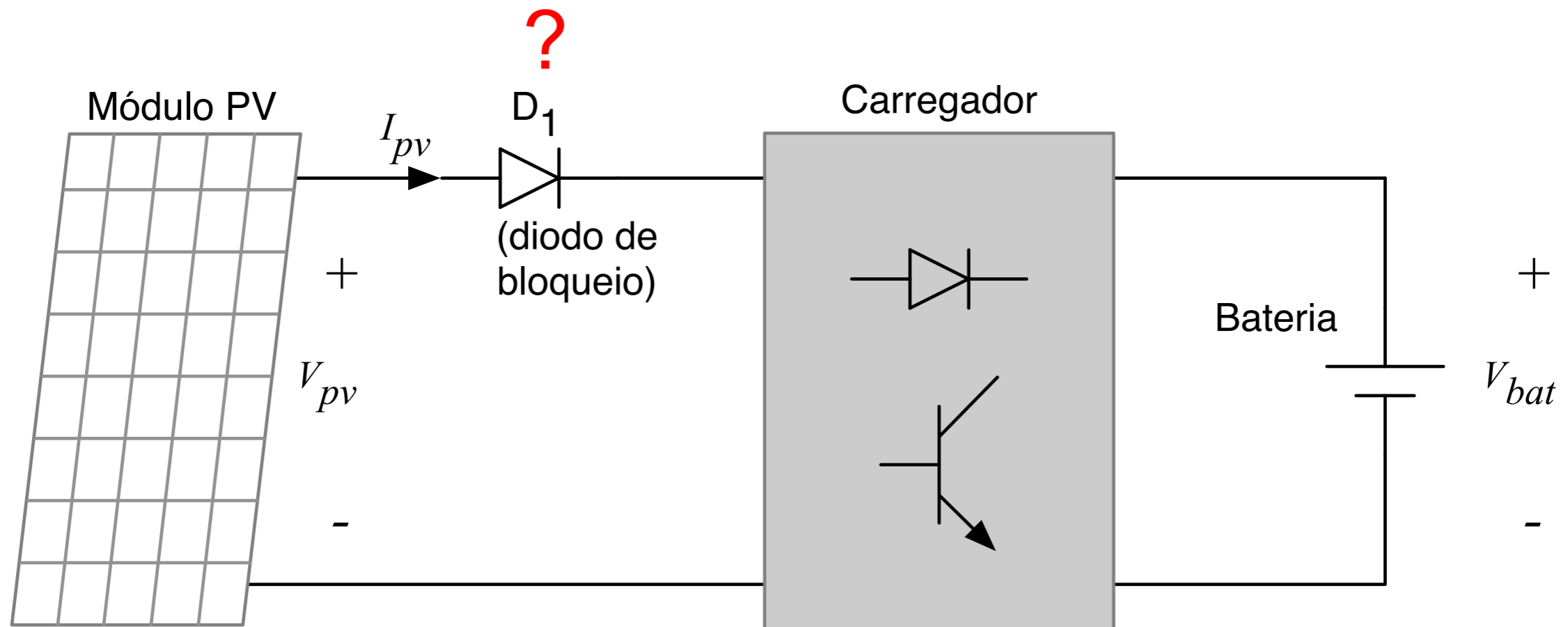

# Dimensionamento e Especificação de Semicondutores

## Exemplo 1:

- Especificando o diodo:
  - Tensão máxima =  $18 \cdot 1,5 > 30 \text{ V}$ ;
  - Corrente máxima =  $200 \cdot 2 > 500 \text{ mA}$ ;
  - Corrente média =  $200 \cdot 1,2 > 250 \text{ mA}$ ;
  - Diodo lento, para corrente contínua.

## Diodes (1822)

ESD Protection Diodes &  
Arrays (129)

Schottky Diodes &  
Rectifiers (374)

Small Signal Switching  
Diodes (112)

Transient Voltage Suppressors  
(TVS) (521)

Tuning Diodes (7)















Zener Diodes (679)



# Dimensionamento e Especificação de Semicondutores

## Exemplo 1:

- Escolhendo o diodo:

Select	Product	Data Sheet	Pb-free	Status	Description	V <sub>RRM</sub> Min (V)	V <sub>F</sub> Max (V)	I <sub>RM</sub> Max (µA)	I <sub>O(rec)</sub> Max (A)	I <sub>FSM</sub> Max (A)	t <sub>rr</sub> Max (ns)	C <sub>j</sub> Max (pF)	Package	Price
<input type="checkbox"/>	<a href="#">MBR0530T1</a>		<input type="checkbox"/>	Active	0.5 A, 30 V Schottky Rectifier	30	0.43 	130 	0.5	5.5			SOD-123 2 LEAD	\$0.1267
<input type="checkbox"/>	<a href="#">MBR0530T1G</a>			Active	0.5 A, 30 V Schottky Rectifier	30	0.43 	130 	0.5	5.5			SOD-123 2 LEAD	\$0.1175
<input type="checkbox"/>	<a href="#">MBR0530T3G</a>			Active	0.5 A, 30 V Schottky Rectifier	30	0.43 	130 	0.5	5.5			SOD-123 2 LEAD	\$0.1175
<input type="checkbox"/>	<a href="#">NSR0530P2T5G</a>			Active	30V 0.5A low VF SOD-923 Schottky Diode	30	0.46 	200 	0.5				SOD-923, 0.40 Max Height	\$0.064

[www.onsemi.com](http://www.onsemi.com)



## Features

- Very Low Forward Voltage Drop - 370 mV @ 100 mA
- Low Reverse Current - 1.4 µA @ 10 V VR
- 500 mA of Continuous Forward Current
- Power Dissipation of 190 mW with Minimum Trace
- Very High Switching Speed
- Low Capacitance - C<sub>T</sub> = 10 pF
- This is a Pb-Free Device

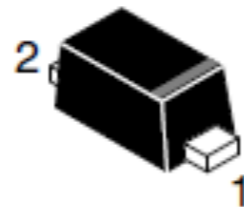

# Dimensionamento e Especificação de Semicondutores

## Exemplo 2:

- Considerando o circuito abaixo:
  - Tensão da rede  $220\text{ V} \pm 20\%$ ;
  - Carga (chuveiro) de  $6800\text{ W}$ ;
  - Pior caso = tiristor conduzindo o tempo todo.

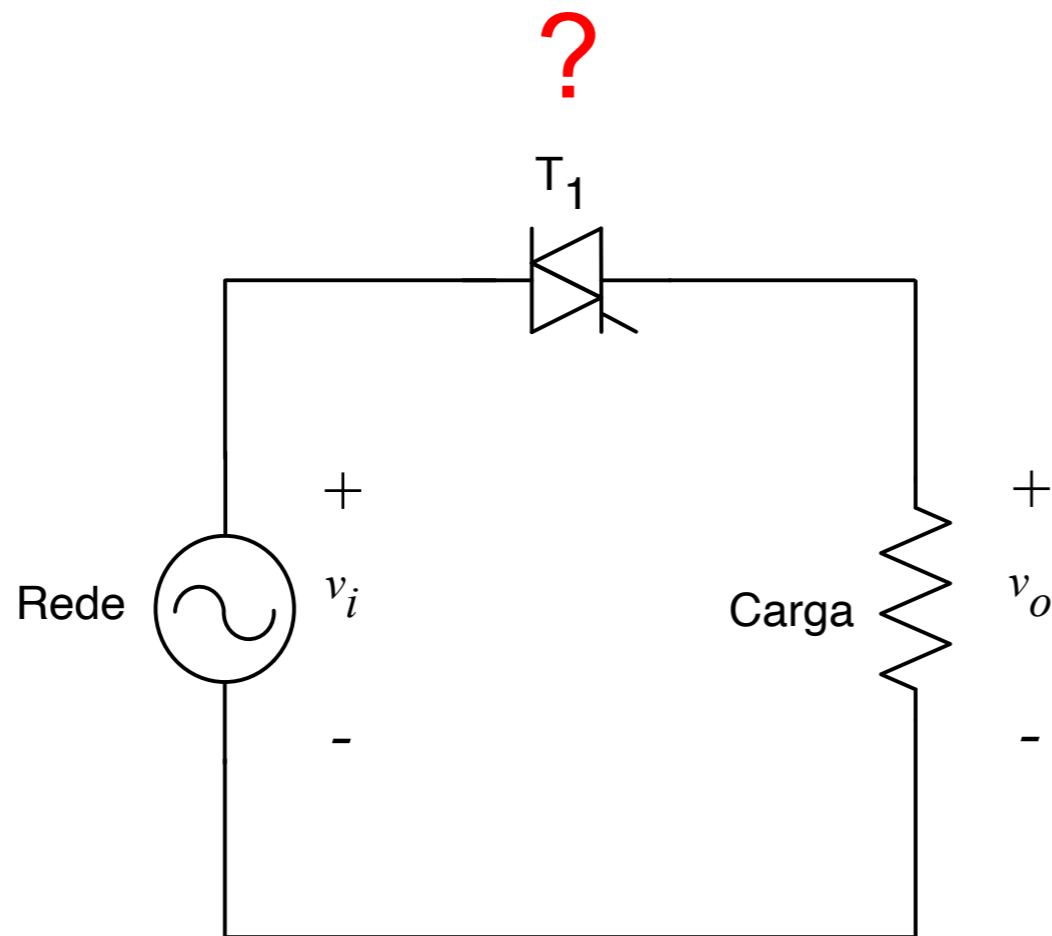

# Dimensionamento e Especificação de Semicondutores

## Exemplo 2:

- Especificando o tiristor:
  - Tensão máxima =  $[(220+20\%) \cdot 1,41] \cdot 1,2 > 500 \text{ V}$ ;
  - Corrente máxima =  $[(6800/220) \cdot 1,41] \cdot 1,2 > 53 \text{ A}$ ;
  - Corrente eficaz =  $(6800/220) \cdot 1,2 > 37 \text{ A}$ ;
  - Tiristor lento, para 60 Hz.

## Thyristors (456)

Programmable Unijunction  
Transistors (PUTs) (12)

SIDACs (11)

Silicon Controlled Rectifiers  
(SCRs) (163)

Thyristor Surge Protection  
Devices (TSPDs) (93)

Triacs (177)



Não atende!!



# Dimensionamento e Especificação de Semicondutores

## Exemplo 2:

- Especificando o tiristor:
  - Tensão máxima =  $[(220+20\%) \cdot 1,41] \cdot 1,2 > 500 \text{ V}$ ;
  - Corrente máxima =  $[(6800/220) \cdot 1,41] \cdot 1,2 > 53 \text{ A}$ ;
  - Corrente eficaz =  $(6800/220) \cdot 1,2 > 37 \text{ A}$ ;
  - Tiristor lento, para 60 Hz.

## Thyristors & AC Switches Families

### SCR

Sensitive Gate SCRs  
Standard SCRs  
Voltage Switches

### Triac

Snubberless High Tj Triacs  
Standard and Snubberless Triacs

### Diac

Diacs

### AC Switches

AC Switch

### ASD Thyristor

Ignitors Industrial  
Ignitors Lighting  
Power Control

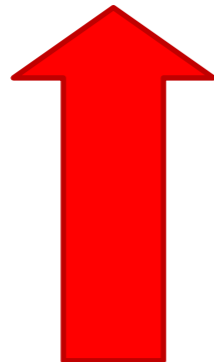

# Dimensionamento e Especificação de Semicondutores

## Exemplo 2:

- Escolhendo o tiristor:

Generic Part Number		Orderable Part Number	Status
<u>BTA40</u>	Purchase	<u>BTA40-600B</u>	Active
	Purchase	<u>BTA40-800B</u>	Active
<u>BTA41</u>	Purchase	<u>BTA41-600BRG</u>	Active
	Purchase Samples	<u>BTA41-800BRG</u>	Active
<u>BTB41</u>	Purchase	<u>BTB41-800BRG</u>	Active
	Purchase Samples	<u>BTB41-600BRG</u>	Active



Symbol	Parameter	BTA40 <sup>(1)</sup>	BTA41 <sup>(1)</sup>	BTB41	Unit
$I_{T(RMS)}$	On-state rms current	40	41	41	A
$V_{DRM}/V_{RRM}$	Repetitive peak off-state voltage	600 and 800	600 and 800	600 and 800	V
$I_{GT}$	Triggering gate current	50	50	50	mA

# Cálculo Térmico

## Cálculo térmico:

- Objetivo de verificar a necessidade de uso de dissipador de calor ou não.
- Modelo térmico:

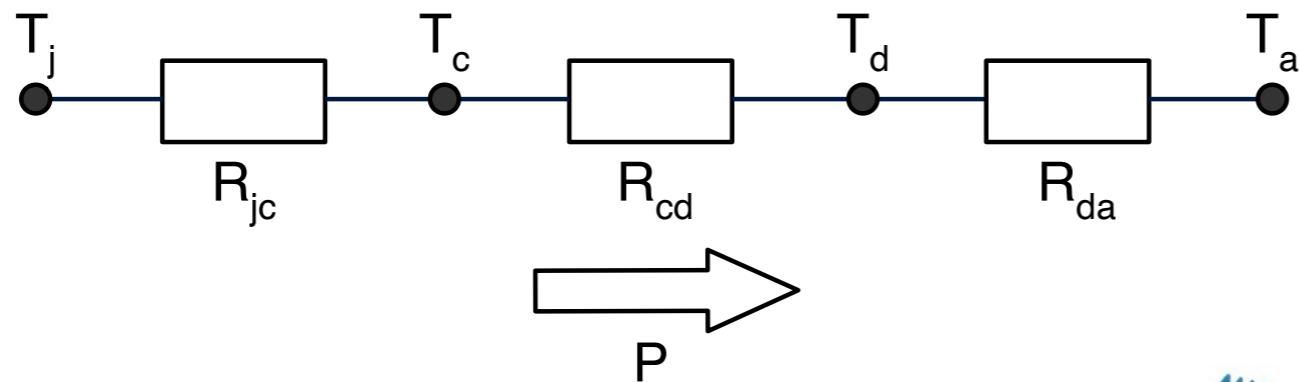

- $T_j$  = temperatura na junção ( $^{\circ}\text{C}$ );
- $T_c$  = temperatura na cápsula ( $^{\circ}\text{C}$ );
- $T_d$  = temperatura no dissipador ( $^{\circ}\text{C}$ );
- $T_a$  = temperatura ambiente ( $^{\circ}\text{C}$ );
- $R_{jc}$  = resistência térmica entre junção e cápsula ( $^{\circ}\text{C}/\text{W}$ );
- $R_{cd}$  = resistência térmica entre cápsula e dissipador ( $^{\circ}\text{C}/\text{W}$ );
- $R_{da}$  = resistência térmica entre dissipador e ambiente ( $^{\circ}\text{C}/\text{W}$ );
- $P$  = potência dissipada no componente (W).



# Cálculo Térmico

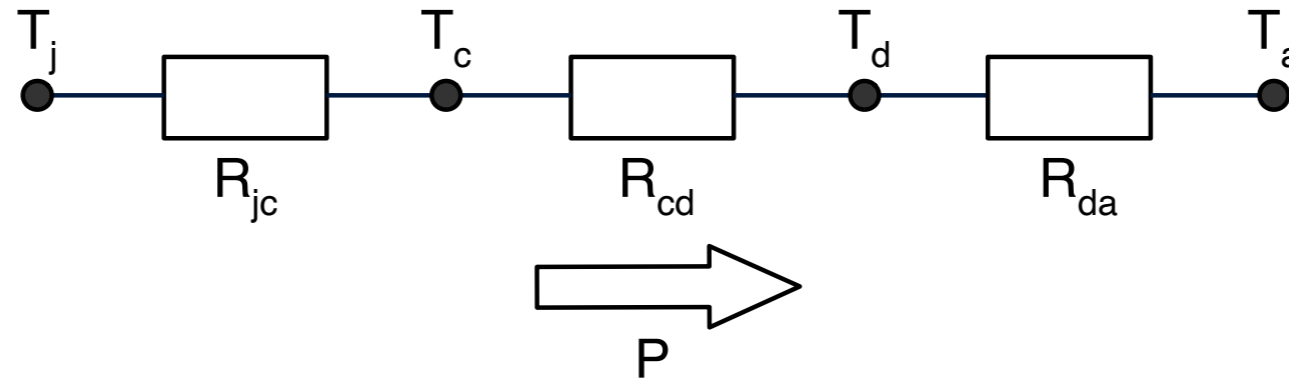

$$R_{ja} = R_{jc} + R_{cd} + R_{da}$$

$$T_j - T_a = R_{ja} \cdot P \quad \Rightarrow \quad R_{ja} = \frac{T_j - T_a}{P}$$

$$R_{da} = R_{ja} - R_{jc} - R_{cd}$$

# Cálculo Térmico

## Exemplo:

- Diodo 1N4007, queda de tensão de 1,1 V, corrente de 0,9 A, temperatura de 30 graus Celsius, resistência térmica entre junção e ambiente de 50 °C/W. Sabendo que a temperatura máxima é de 175 °C. Será preciso usar dissipador?

$$P_D = V_D \cdot I_D = 1,1 \cdot 0,9 = 0,99W$$

$$T_j = T_a + R_{ja} \cdot P = 30 + 50 \cdot 0,99 = 79,5^\circ C$$

Como 79,5 °C é menor do que 175 °C, não precisa dissipador.

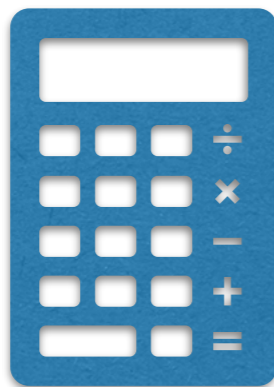

# Cálculo Térmico

## Exemplo:

- MOSFET IRF540 conduzindo 20 A, temperatura ambiente com 40 °C, resistência térmica entre junção e ambiente de 62 °C/W e resistência de 44 mΩ e temperatura máxima na junção de 175 °C. Verificar se precisa dissipador.

$$P_{MOSFET} = R_{DS(on)} \cdot (I_D)^2 = 44m \cdot 20^2 = 17,6W$$

$$T_j = T_a + R_{ja} \cdot P = 40 + 62 \cdot 17,6 = 1131,2^\circ C$$

Como 1131,2 °C é maior do que 175 °C, então precisa dissipador.

$$R_{ja(max)} = \frac{T_j - T_a}{P_{MOSFET}} = \frac{175 - 40}{17,6} = 7,67^\circ C/W$$

$$R_{ja(max)} = R_{jc} + R_{cd} + R_{da} \rightarrow R_{cd} = 1^\circ C/W$$

$$R_{da} = R_{ja(max)} - R_{jc} - R_{cd} = 7,67 - 1 - 1 = 5,67^\circ C/W$$

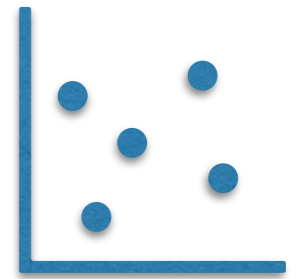
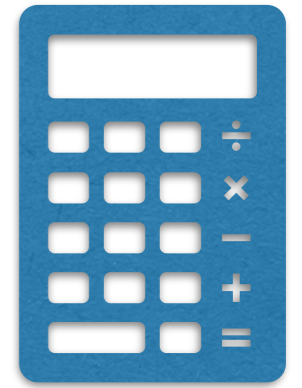

# Cálculo Térmico

## Exemplo:

- Determinar o dissipador necessário:
  - Diodo MSR1560-D;
  - Corrente média = eficaz = 10 A;
  - Temperatura ambiente de 35 °C;
  - Considerar  $R_{cd} = 1 \text{ °C/W}$ ;
  - Considerar apenas as perdas por condução.



# Cálculo Térmico

Online Calculator .. Heatsink - Windows Internet Explorer

http://www.changpuak.ch/electronics/calc\_23.html

Arguivo Editar Exibir Favoritos Ferramentas Ajuda

★ Favoritos

NI LabVIEW - Improving th... Online Calculator .. He... x

Página Segurança

**NAVIGATION**

← go back



**MORE INFORMATION**

Berechnung Kühlkörper

Heatsink Calculation

**LIEBES ELEKTOR TEAM,  
WER HAT'S ERFUNDEN ?**

## ONLINE HEATSINK CALCULATOR

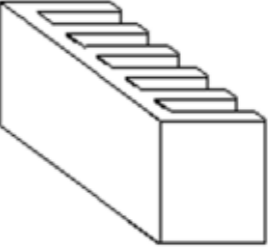
**Transistor**

**Thermal Pad**

**Heatsink**

$T_j$   °C

$R_{th,j-a}$   °C/W

$P_{diss}$   W

$T_a$   °C

$R_{th}$   °C/W

Concluído

Internet | Modo Protegido: Ativado

100%

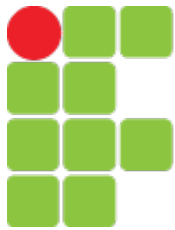

# Cálculo Térmico

Natural Convection for Rectangular Heat Sinks - Windows Internet Explorer

http://www.mhtlab.uwaterloo.ca/NC\_rect.html

## Natural Convection for Rectangular Heat Sinks

Model Specifications	
Configuration:	Single ▾
Solve for:	Source Temperature ▾
Non-Uniform Fin Temperature:	<input type="checkbox"/>
Back Insulated:	<input type="checkbox"/>

### Maximum Outer Dimensions

[What is this?](#)

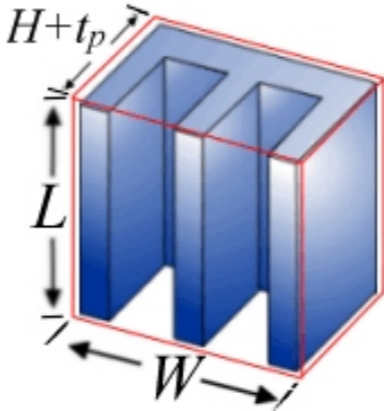

Depth  
 $H + t_p$  [mm]

Length  
 $L$  [mm]

Width  
 $W$  [mm]

### Input Values and Results

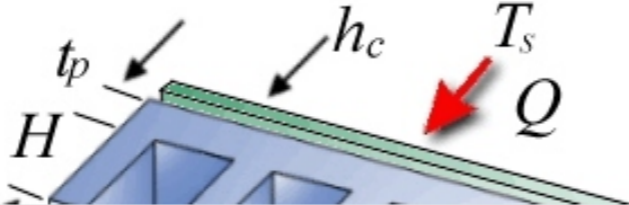

Baseplate Thickness

Contact Conductance  
 $h_c$  [ $W/m^2 \cdot ^\circ C$ ]

Concluído

Internet | Modo Protegido: Ativado

100%

# Próxima Aula

## Retificadores monofásicos:

- Carga resistiva.

