

Centro Federal de Educação Tecnológica de Santa Catarina
Departamento Acadêmico de Eletrônica
Conversores Estáticos

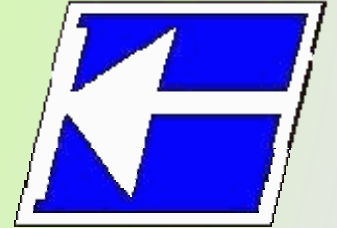

Semicondutores Aplicados
a Conversores CA-CA
IGBTs e MOSFETs

Prof. Clóvis Antônio Petry.

Florianópolis, setembro de 2008.

Bibliografia para esta aula

Capítulo 3: Transistores de potência

1. Semicondutores aplicados a conversores CA-CA.

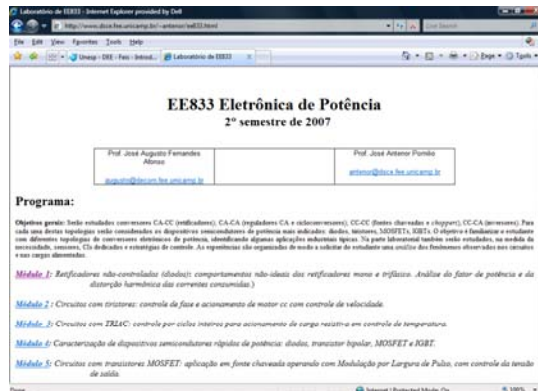
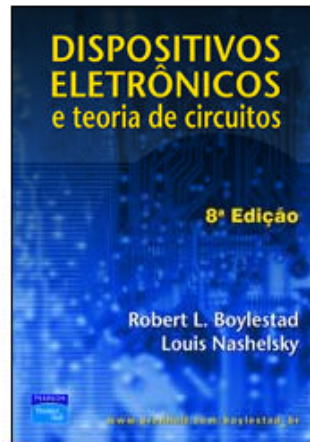
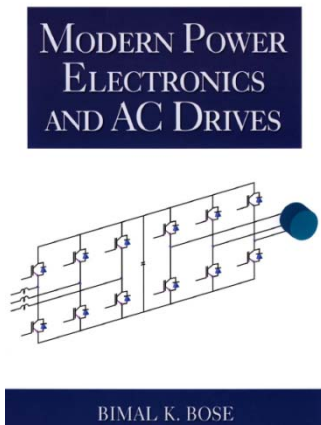

www.cefetsc.edu.br/~petry

<http://www.dsce.fee.unicamp.br/~antenor/>

Nesta aula

Semicondutores aplicados a conversores CA-CA:

1. Introdução;
2. Revisão dos principais componentes semicondutores de potência;
3. MOSFET de potência;
4. IGBT;
5. Comparativo BJT x MOSFET x IGBT.

Quadrantes de condução de semicondutores

Operações Básicas Desejadas

Operação em um quadrante

- ◆ Diodos (bloqueio reverso)
- ◆ SCR (bloqueio direto)
- ◆ Transistor Bipolar
- ◆ IGBT

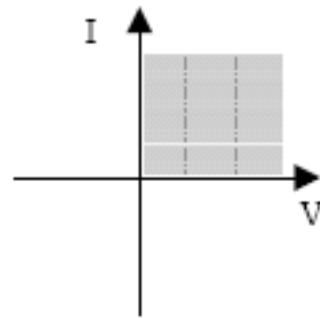

Operação em dois quadrantes com tensão bidirecional

- ◆ SCR (bloqueio direto e reverso)
- ◆ Transistor Bipolar + diodo em série

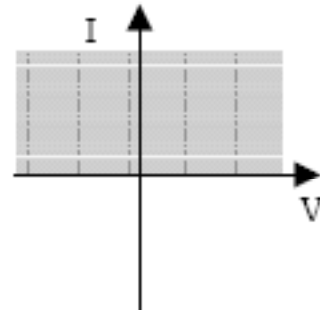

Operação em dois quadrantes com corrente bidirecional

- ◆ MOSFET
- ◆ SCR + diodo em anti-paralelo
- ◆ IGBT + diodo em anti-paralelo
- ◆ Transistor Bipolar + diodo em anti-paralelo

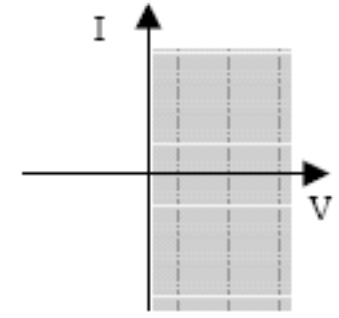

Operação em quatro quadrantes

- ◆ Arranjo de diodos com transistores bipolares

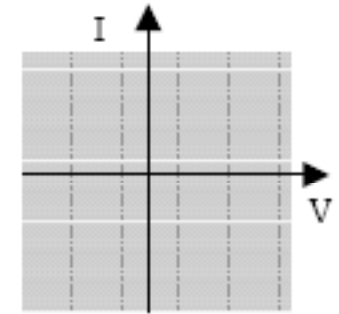

Semicondutores para eletrônica de potência

Semicondutores utilizados em eletrônica de potência:

- Diode
- Thyristor or silicon-controlled rectifier (SCR)
- Triac
- Gate turn-off thyristor (GTO)
- Bipolar junction transistor (BJT or BPT)
- Power MOSFET
- Static induction transistor (SIT)
- Insulated gate bipolar transistor (IGBT)
- MOS-controlled thyristor (MCT)
- Integrated gate-commutated thyristor (IGCT)

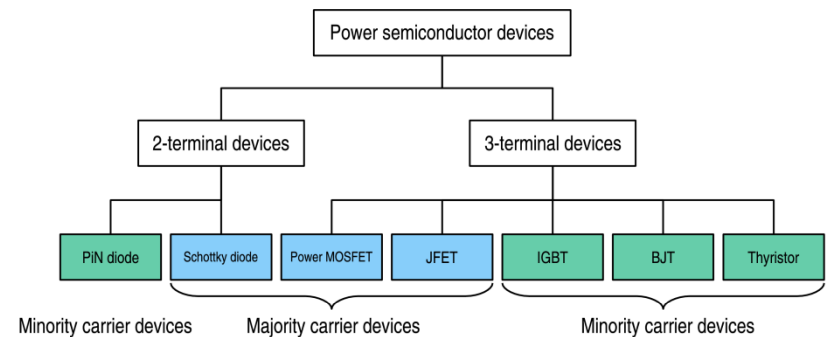

Semicondutores para eletrônica de potência

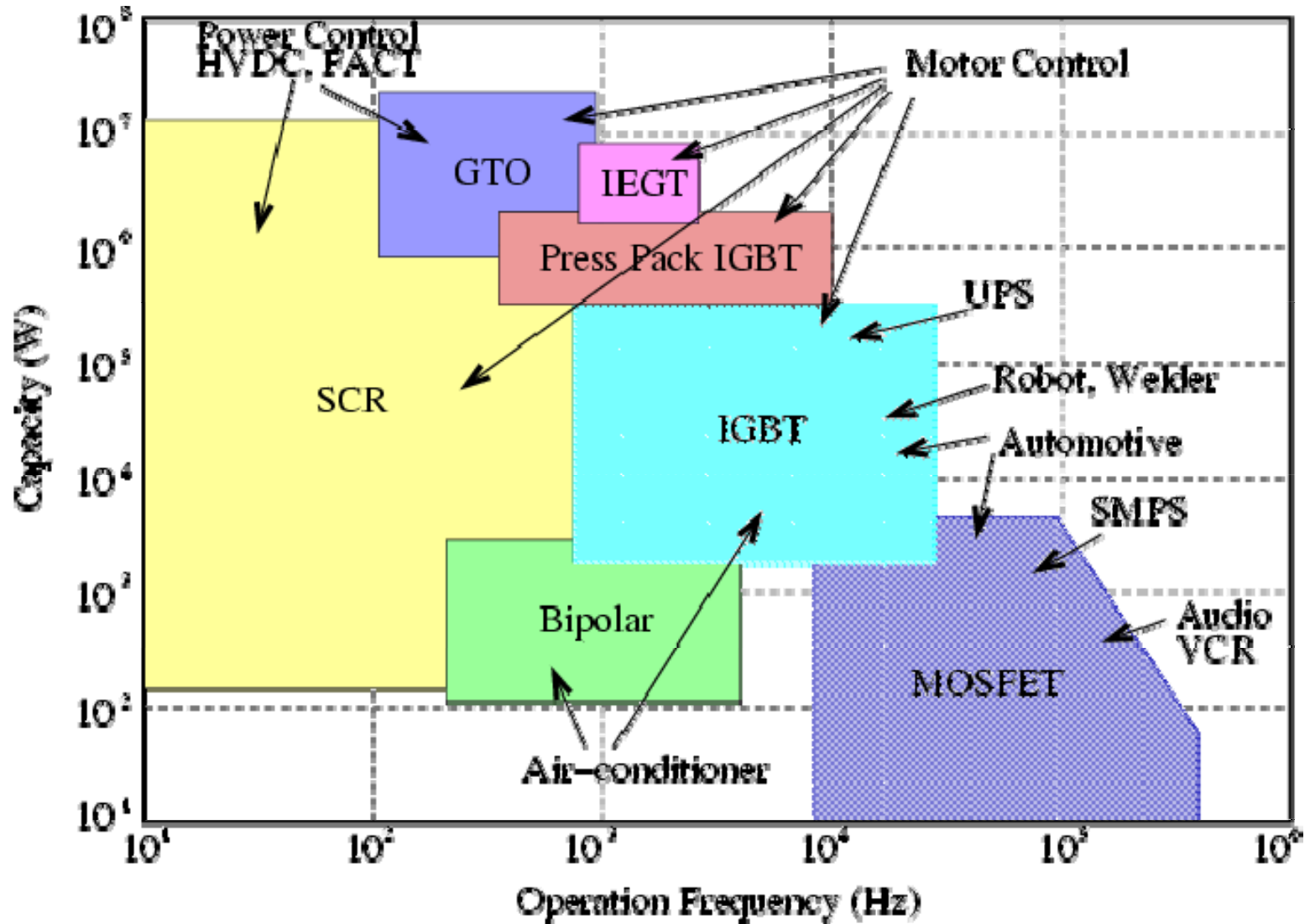

Semicondutores para eletrônica de potência

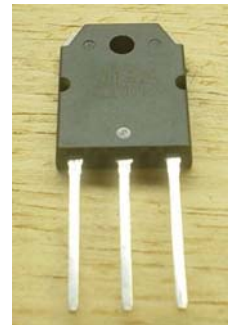

Revisão - Diodos

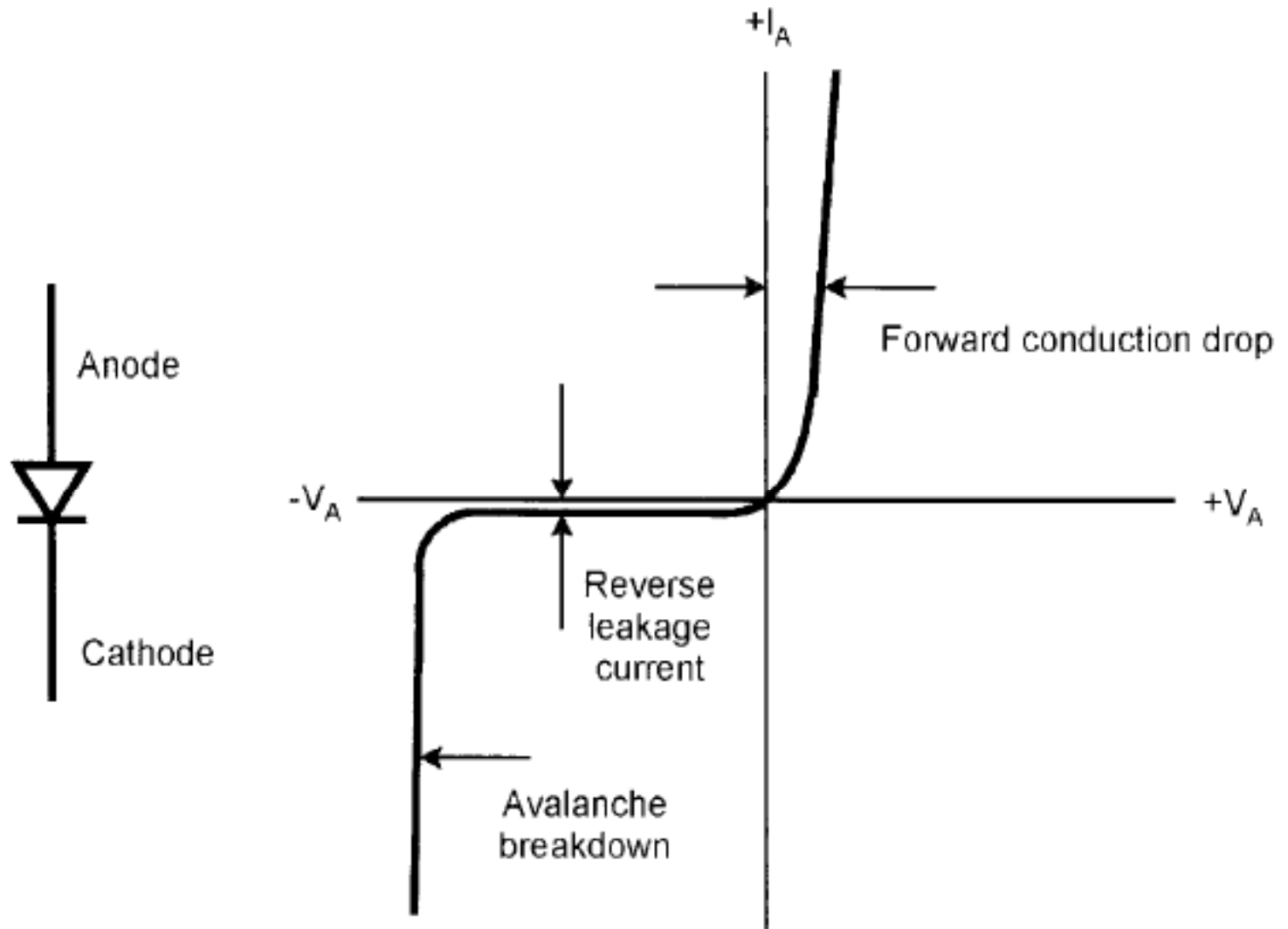

Revisão - Diodos

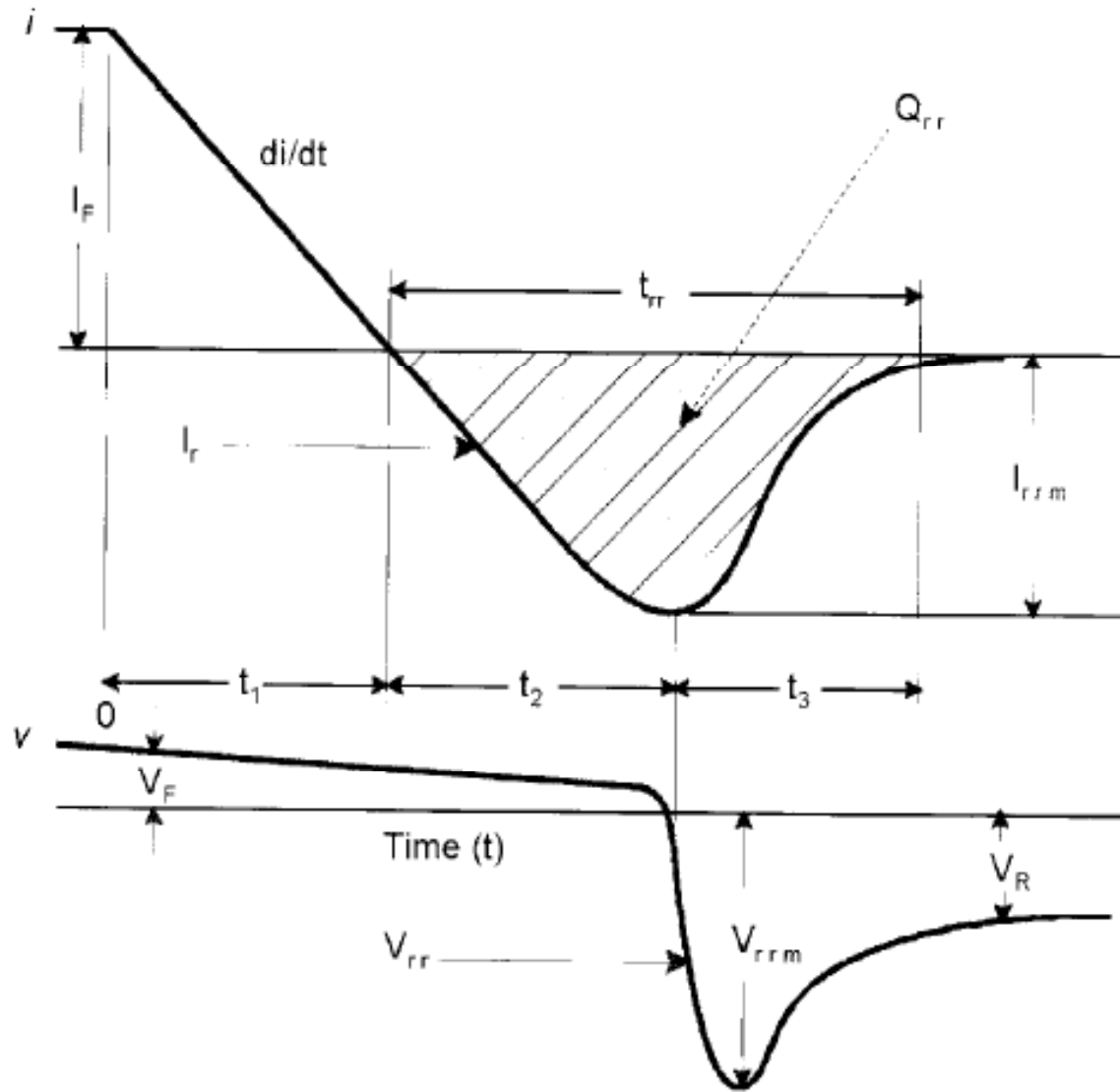

Revisão - Tiristores

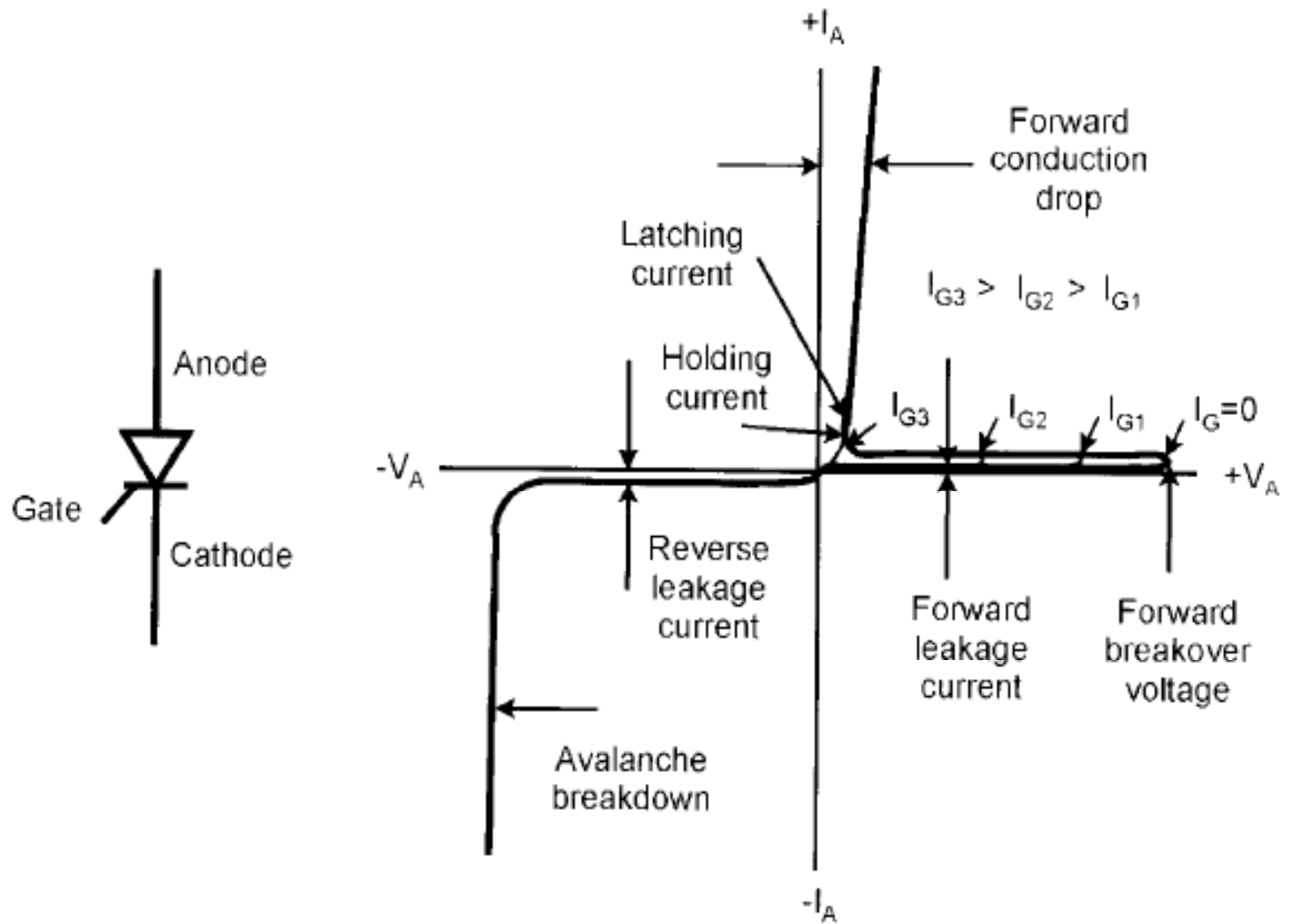

Revisão - Tiristores

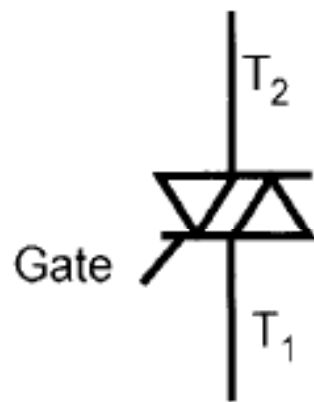

(a)

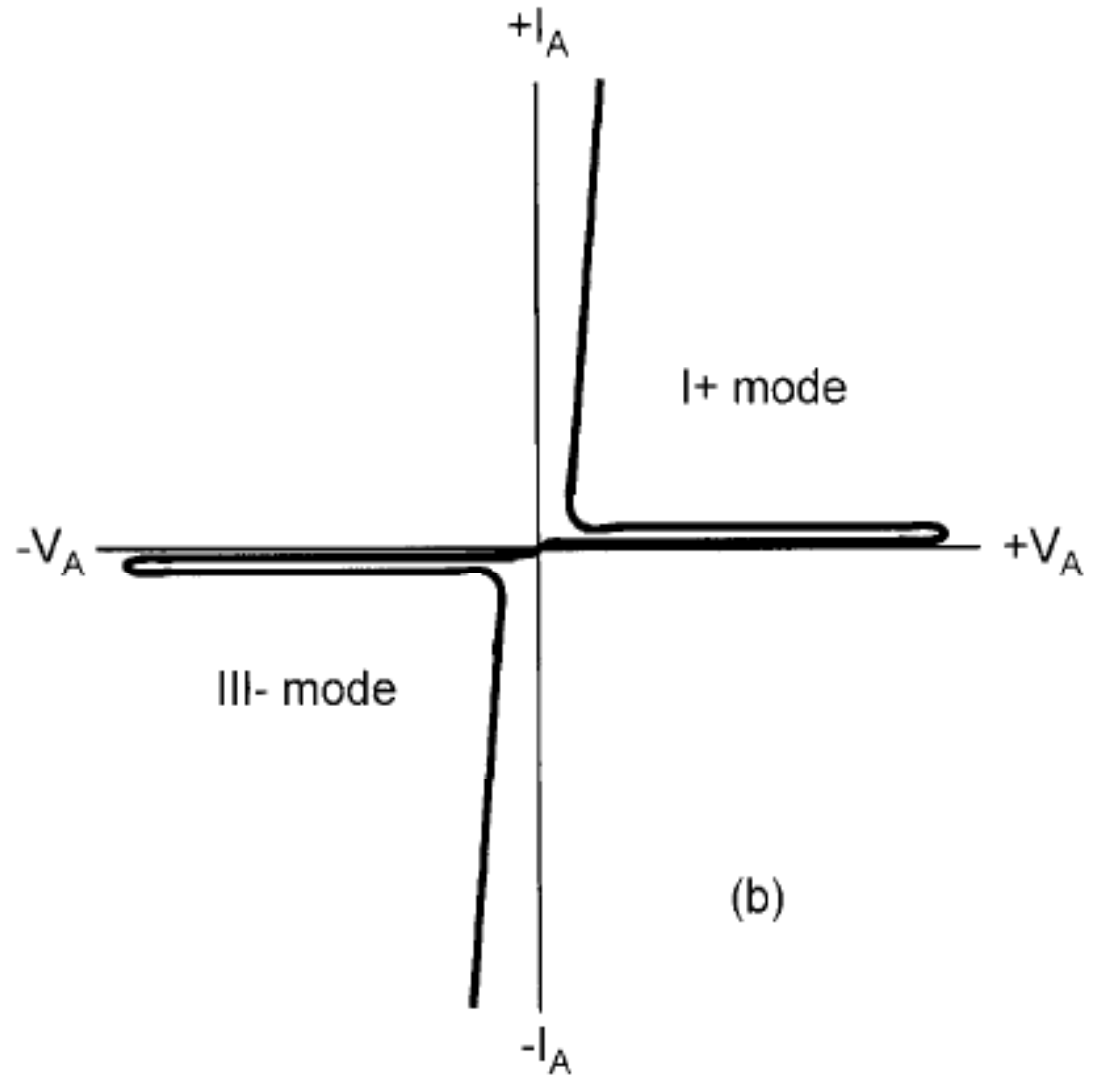

(b)

Revisão - BJT

Électronique - Internet Explorer provided by Dell
http://www.univ-lemans.fr/enseignements/physique/02/electro/mnueltro.html

Électronique

Oscilloscope cathodique	Diodes et transistors	Filtres	Logique
<ul style="list-style-type: none">PrincipeSynchronisationFonctionnement en bicourbeFigures de LissajousMesure de déphasageMesure de fréquencesBalavage télévision	<ul style="list-style-type: none">Pont de GraetzFiltrage (animation)Redressement et filtrageRégulateur à diode ZenerTransistor (principe)Transistor en régime variable	<ul style="list-style-type: none">Filtres passifs (exemples)Filtres passifs (général)Filtres en L, T et PiFiltres en T et T pontéFiltres de Sallen et KayFiltres de Rauch	<ul style="list-style-type: none">Portes logiquesAssociations de NANDsAssociations de NORsBascules R-S et DBascules J-KAdditionneur binaire
Circuits simples	Commutation	Convertisseurs	Capteurs
<ul style="list-style-type: none">Amplificateur opérationnelDiviseur de tensionCircuits RC, Filtres Derivateur IntégrateurCircuits R, L, C série et //Relaxateur à néonDéphaseur passifDéphaseur à AOPGénérateur de courant constantAdaptation d'impédances	<ul style="list-style-type: none">AstableAstable à comparateurMonostableComparateur de Schmitt	<ul style="list-style-type: none">Convertisseur N/A R-2RConvertisseur A/N simple rampeConvertisseur A/N à approximations	<ul style="list-style-type: none">ThermistanceThermomètre à diodeThermomètre Pt500Impédance d'un quartz
Divers	Divers		

Internet | Protected Mode: On 100%

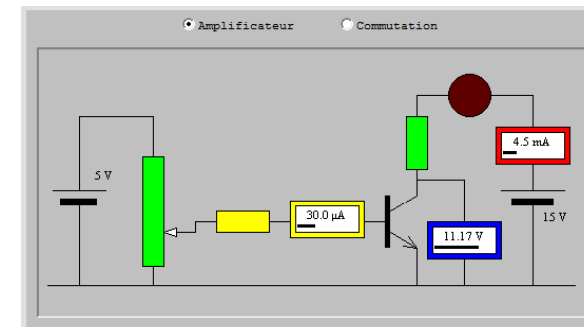

<http://www.univ-lemans.fr/enseignements/physique/02/electro/mnueltro.html>

Revisão - BJT

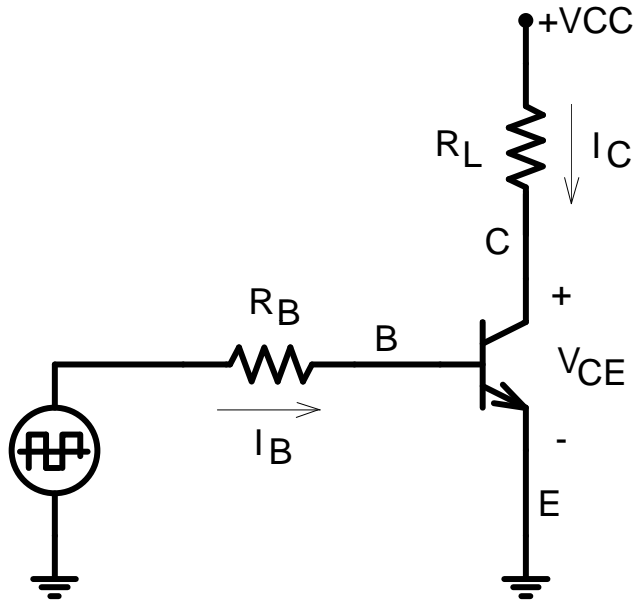

Comutação do BJT com carga resistiva

Comutação do BJT com carga indutiva

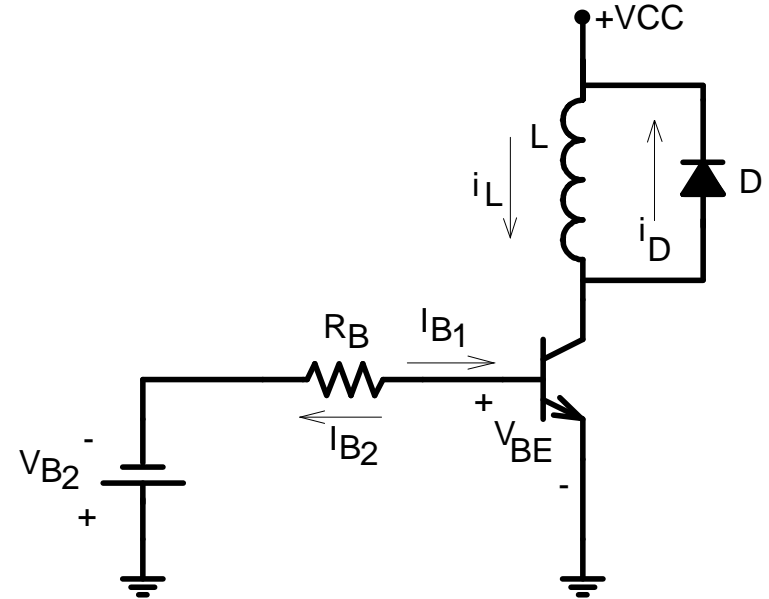

Revisão - BJT

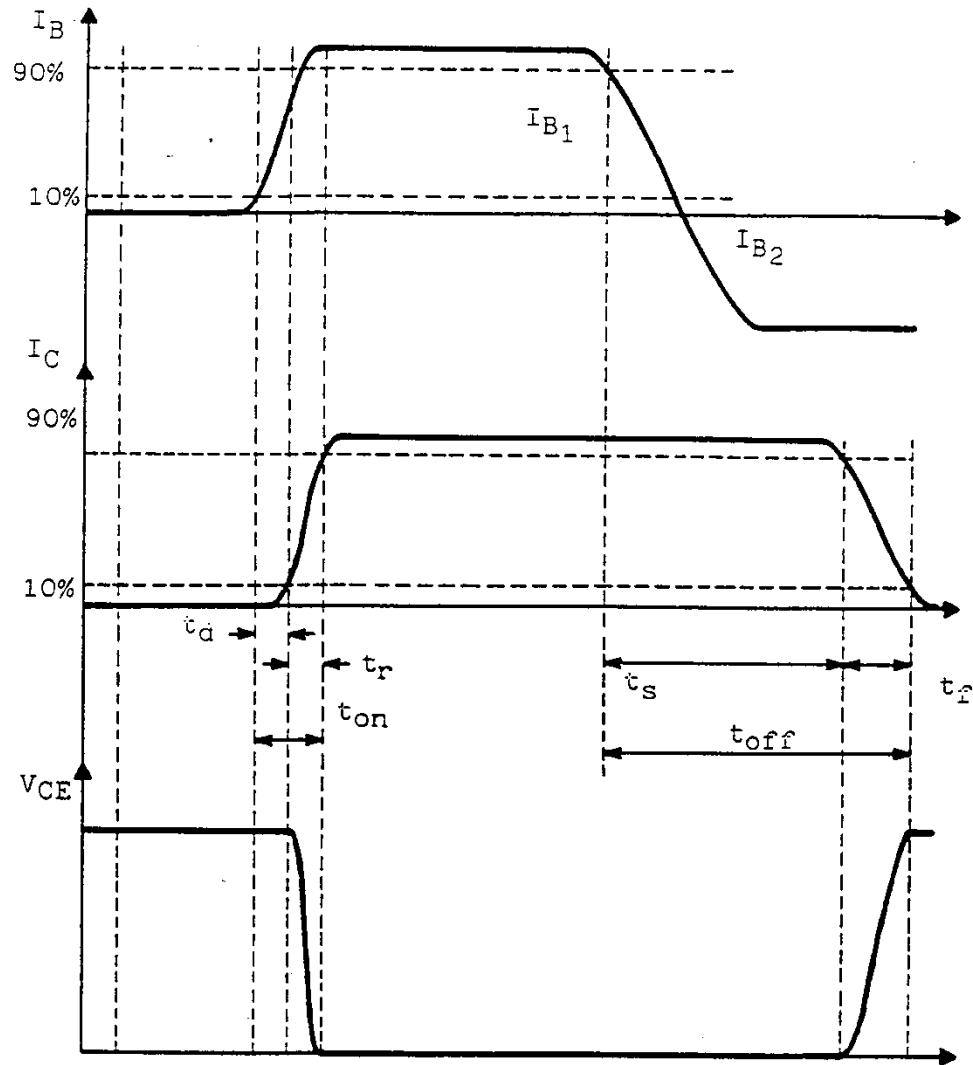

Comutação do BJT com carga resistiva

Revisão - BJT

Entrada em condução

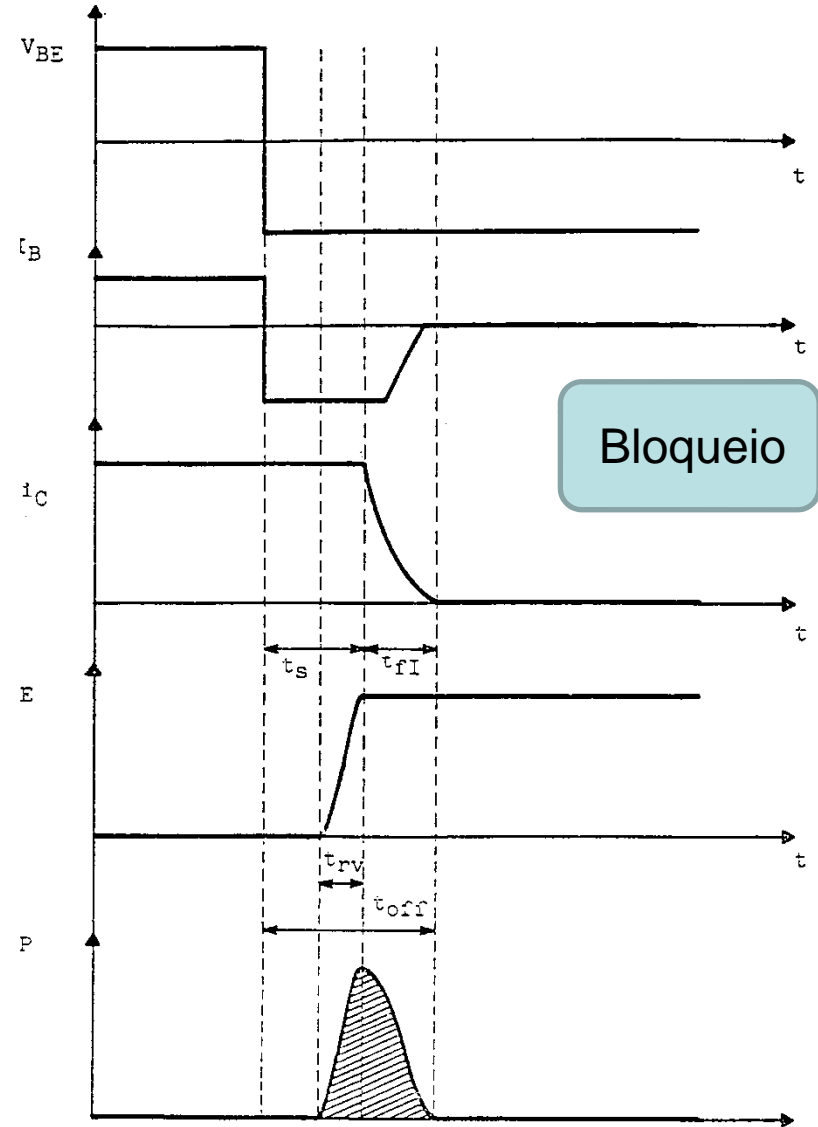
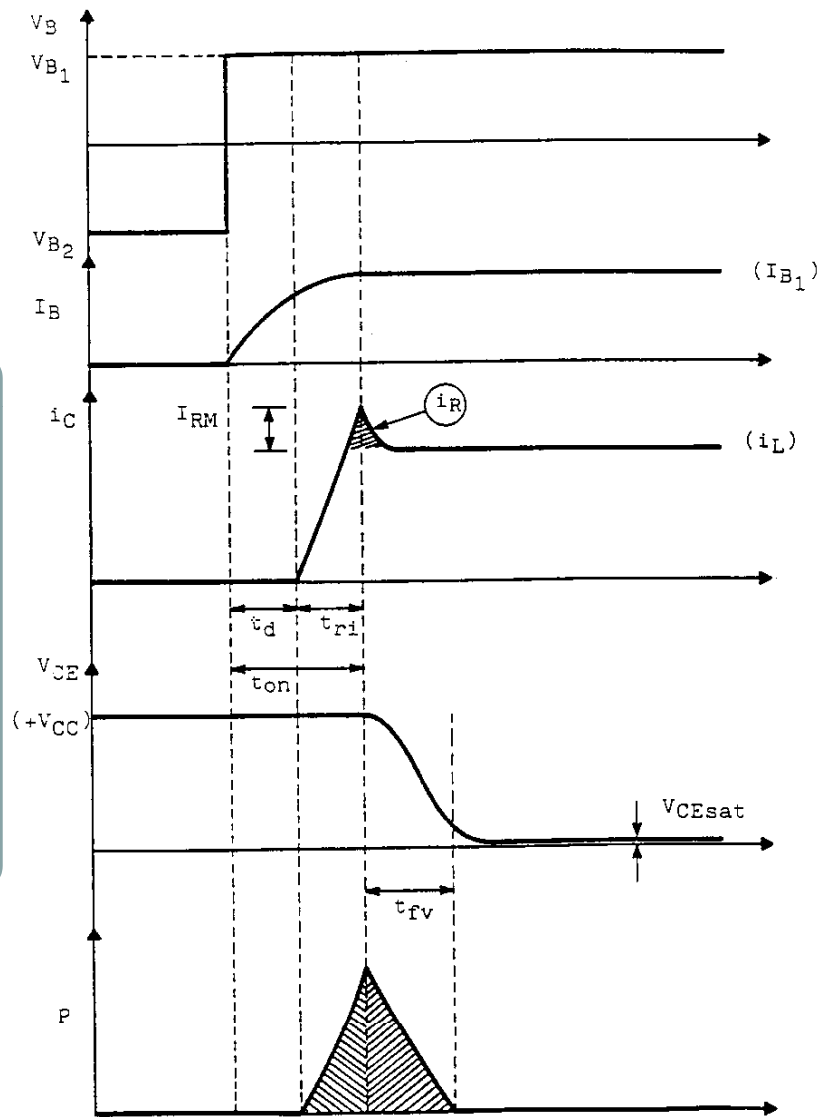

Bloqueio

Comutação do BJT com carga indutiva

BJT x FET

FET – Transistor de efeito de campo

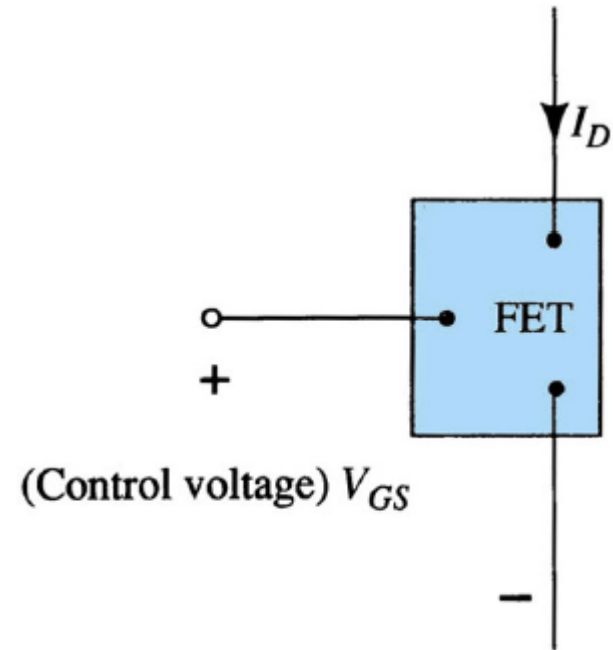
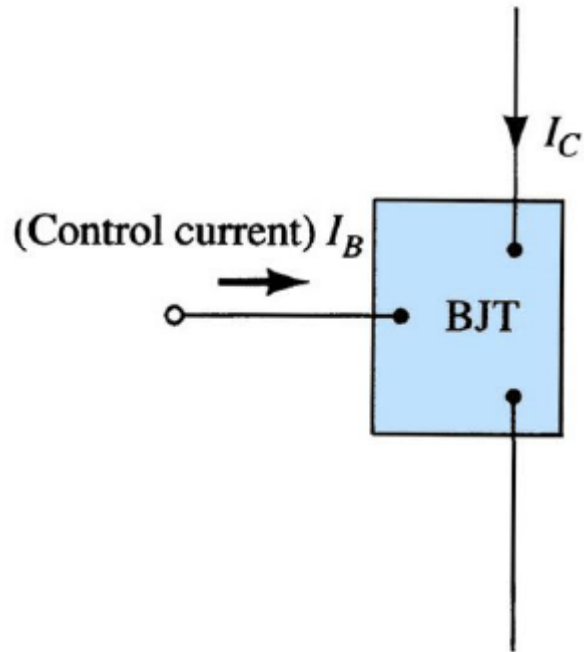

FET

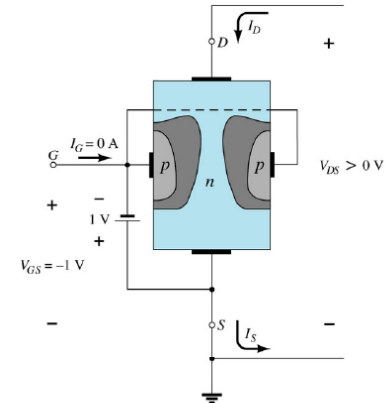
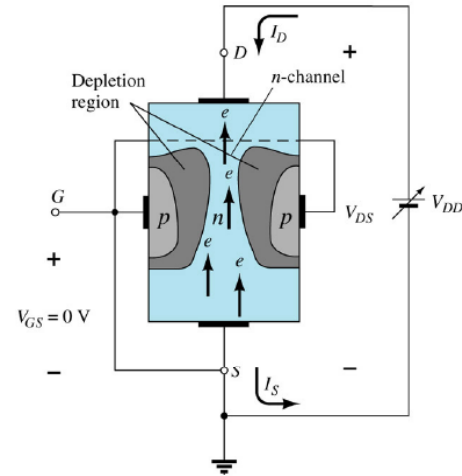
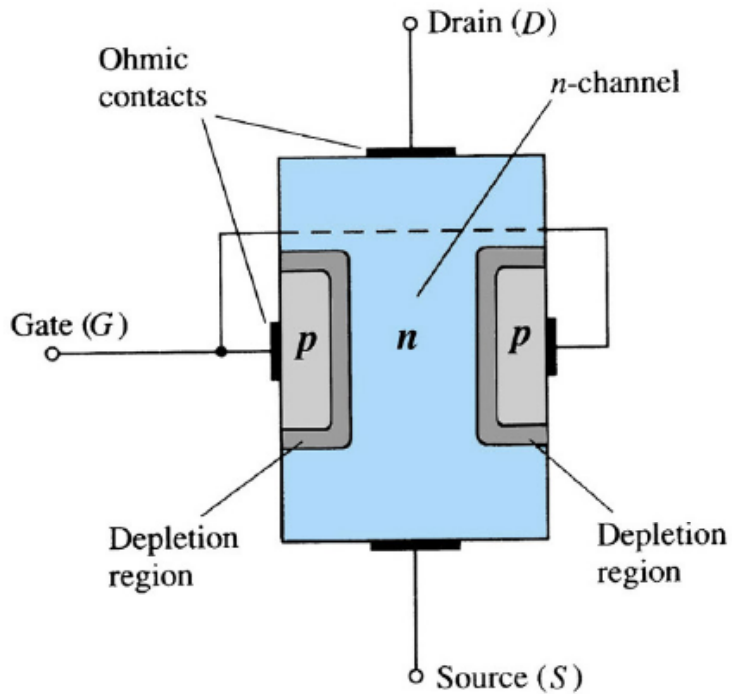

JFET: Operação básica.

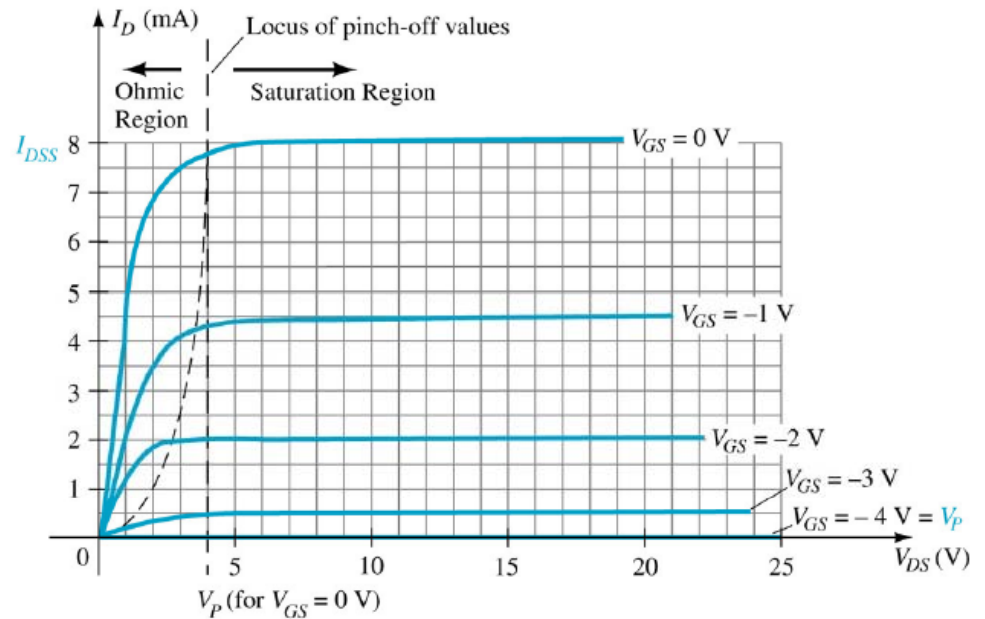

Semiconductor Applet Services - Internet Explorer provided by Dell
 http://jas.eng.buffalo.edu/

File Edit View Favorites Tools Help

Semiconductor Applet Services

JAS

The Semiconductor Applet Service
 (Supported in part by the National Science Foundation)

Educ Applets

Info

Java-related
[Semicond.](#)
[Web sites](#)

Education
[Higher Ed.](#)
[Resources](#)

Semiconductor
[Links](#)
[Java API](#)

Research
[XRD Sites](#)
[Mater. Res.](#)
[Fed Agency](#)

List of Simulation Applets

- Crystal Structure**
 - Zincblende and Diamond structures (GaAs, Si, etc.): [unitcell with a list of material property](#). It gives you the 3D views of the unitcell and the covalent bonds.
 - [Hexagonal Closed Packed structures](#) (ZnS, GaN, SiC, etc.). An interactive 3D view of the crystal unitcell.
 - [Crystal Structure and the 14 Bravais Lattices](#) (java1.3): you can add various Basis atoms, rotate the crystal with one or multiple unitcells for a 3D view. It has many example crystals. You can also view the lattice planes and directions. [Crystal Structure in Java 3D!](#) (Java3D plugin maybe needed: use link in page)
- Energy Bands and Charge Carriers**
 - Visualization of [diffusion, drift and recombination](#) of excess minority carriers in a semiconductor.
 - [Indirect recombination via an energy state in the band gap](#). It also introduces the four basic processes in the Shockley-Read-Hall statistics.
 - Energy Band Diagram and E-k Diagram
 - [AlGaAs](#)
 - [SiGe](#)
- Charge Carriers and Fermi Level** [Semiconductor Statistics]
 - [Fermi Function and Localized Energy States](#) and the Temperature effect.

http://jas.eng.buffalo.edu/

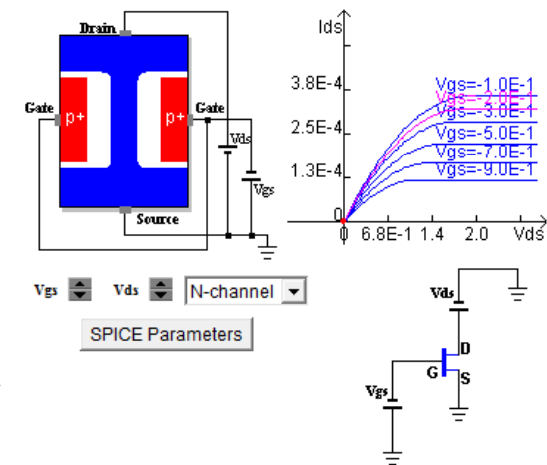

FET

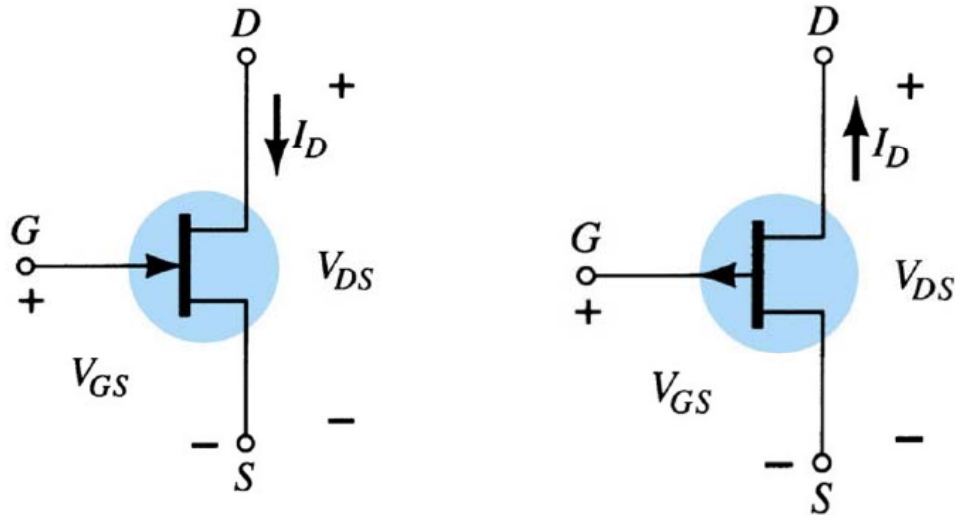

JFET canal n e canal p

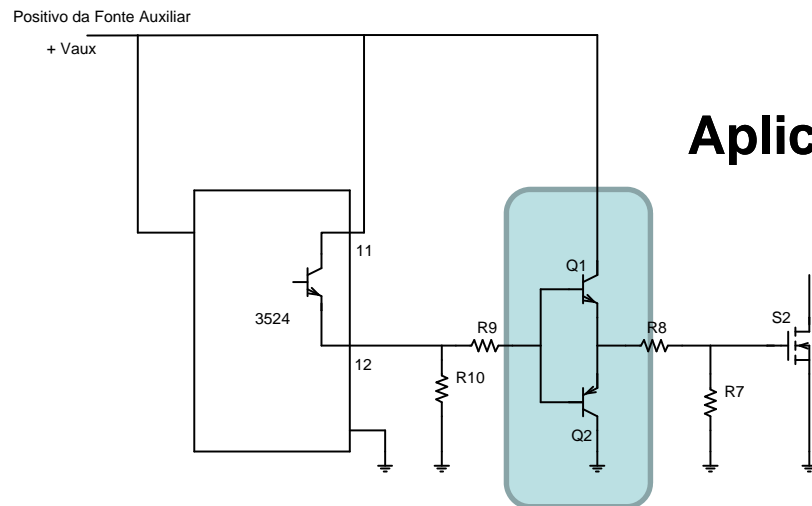
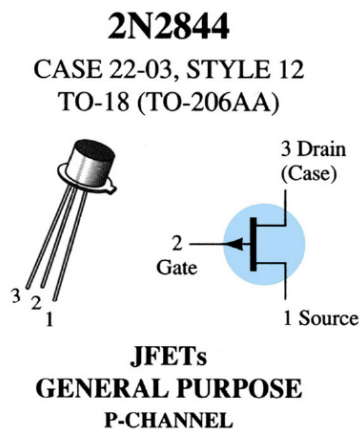
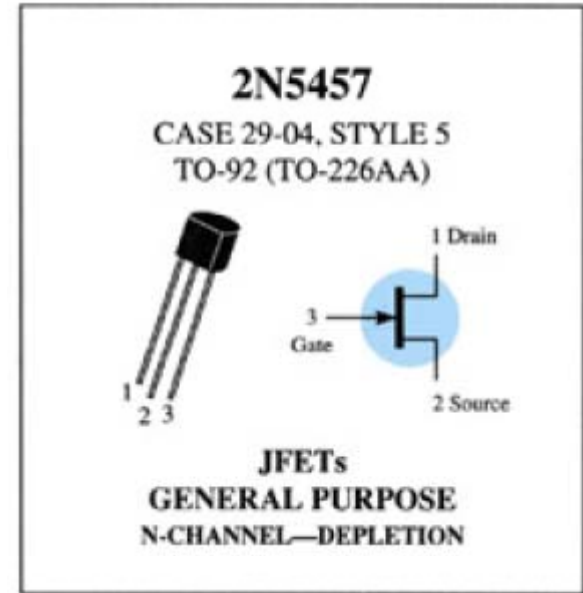

Aplicação do JFET

MOSFET

MOSFET tipo Depleção

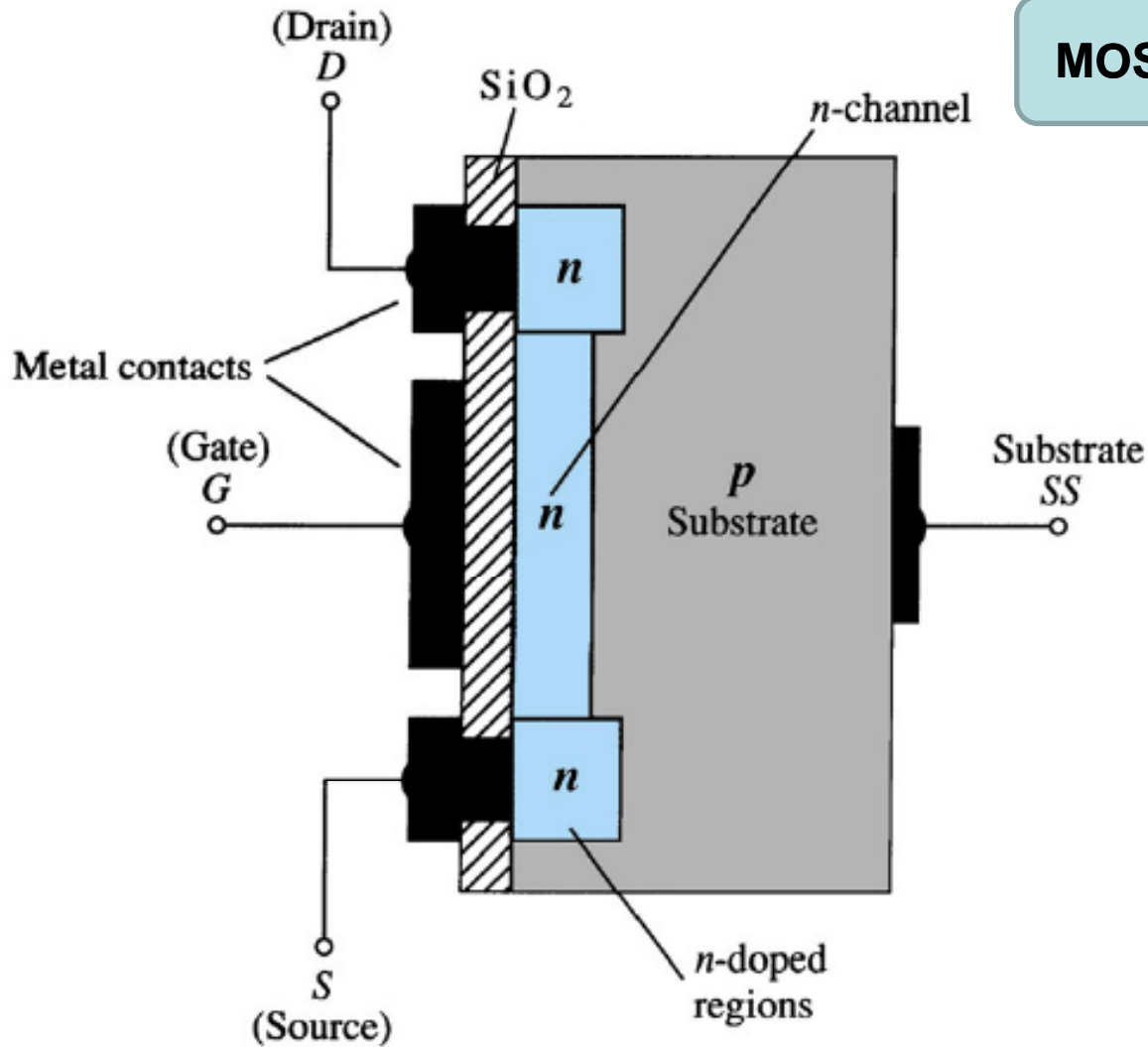

MOSFET – Metal Oxide Semiconductor Field Effect Transistor

MOSFET

MOSFET tipo Depleção

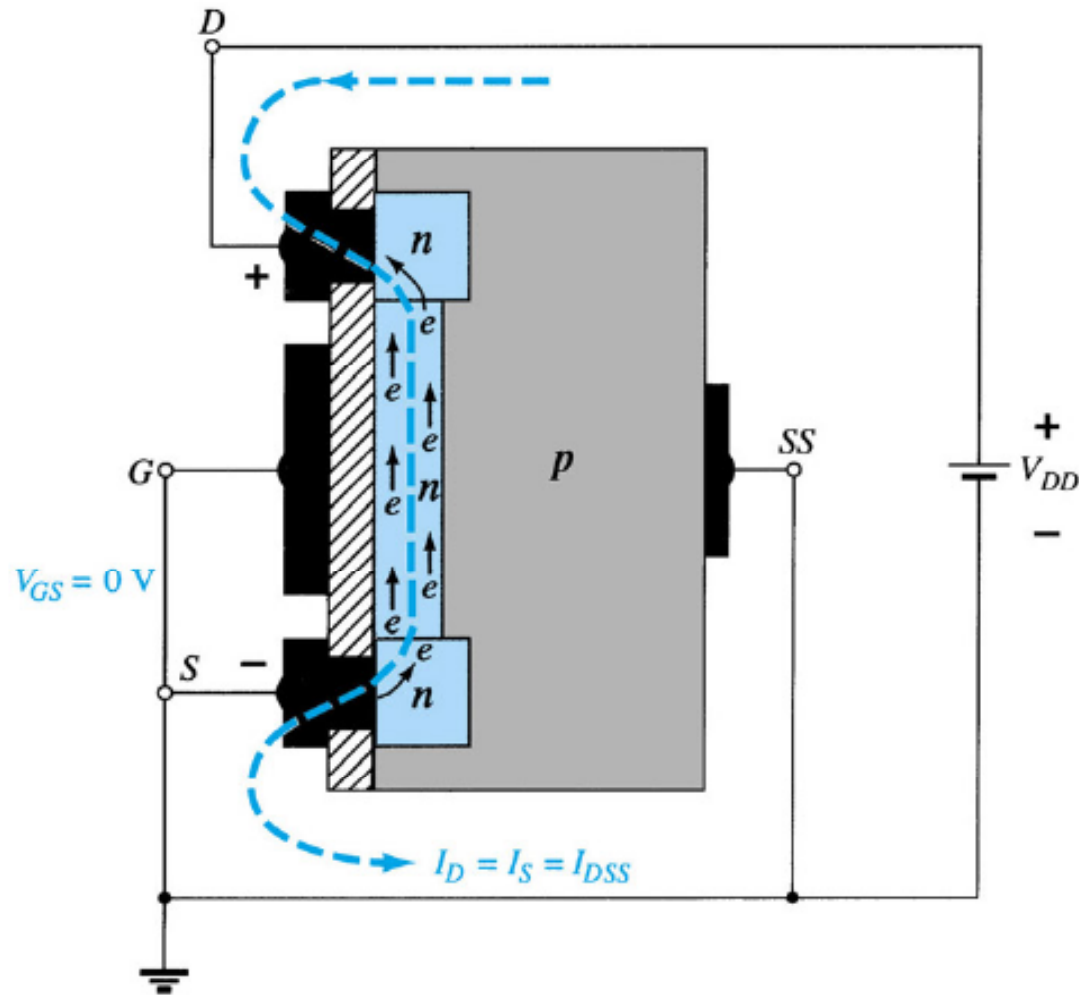

MOSFET: Operação básica.

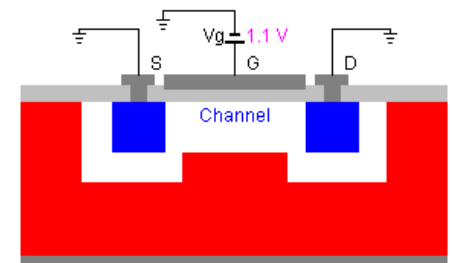

Enhancement-mode (Normally-off) MOSFET

N-channel

$V_g > V_t$: gate bias is more positive than the threshold voltage. Sufficient electrons accumulate and forms the inversion channel

V_g

<http://jas.eng.buffalo.edu/>

MOSFET

MOSFET tipo Depleção

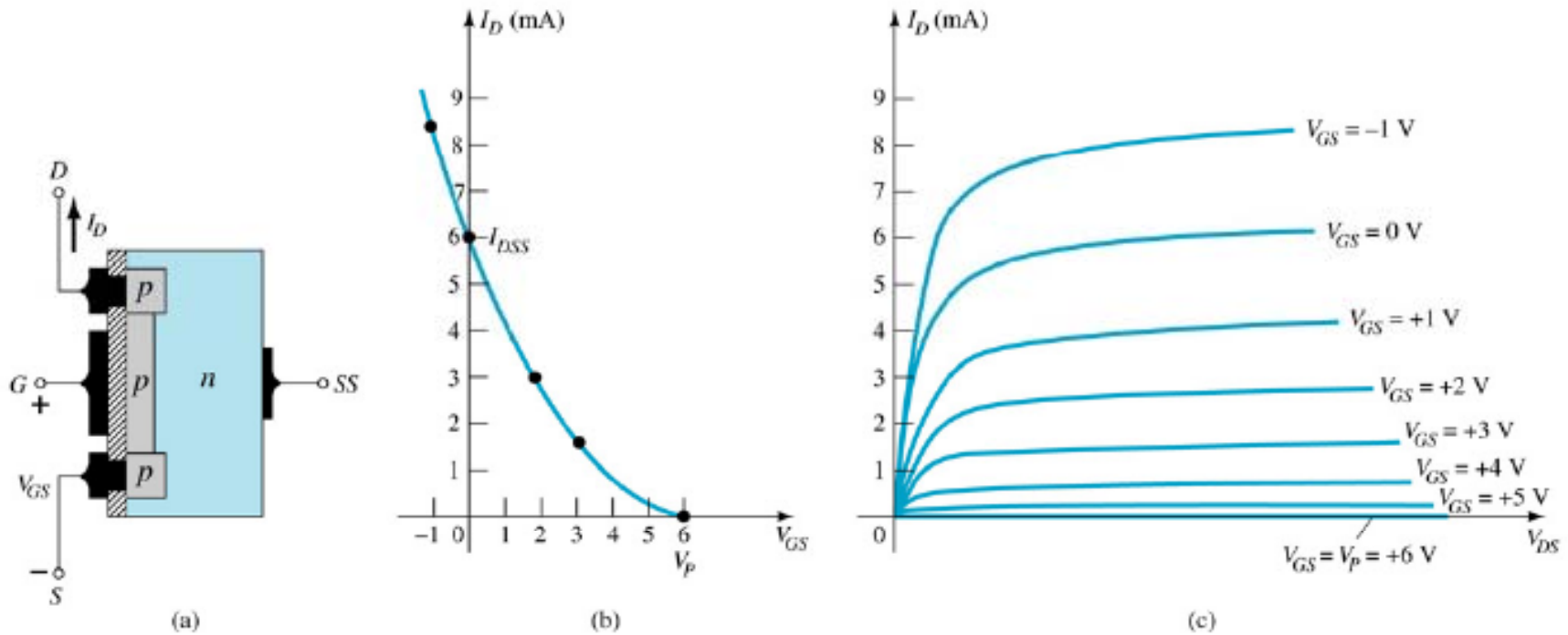

MOSFET: Operação básica.

MOSFET

MOSFET tipo Depleção

n-channel

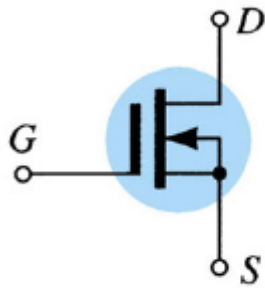
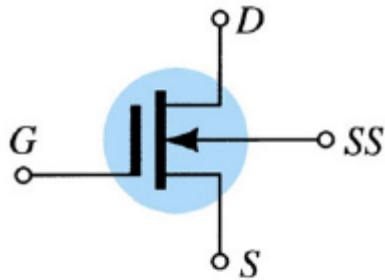

p-channel

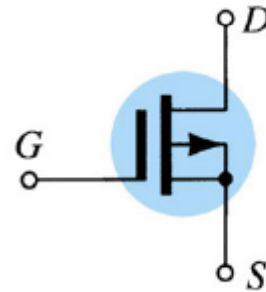
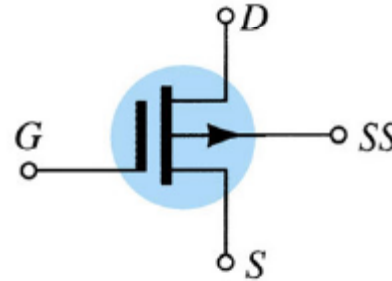

MOSFET

MOSFET tipo Intensificação

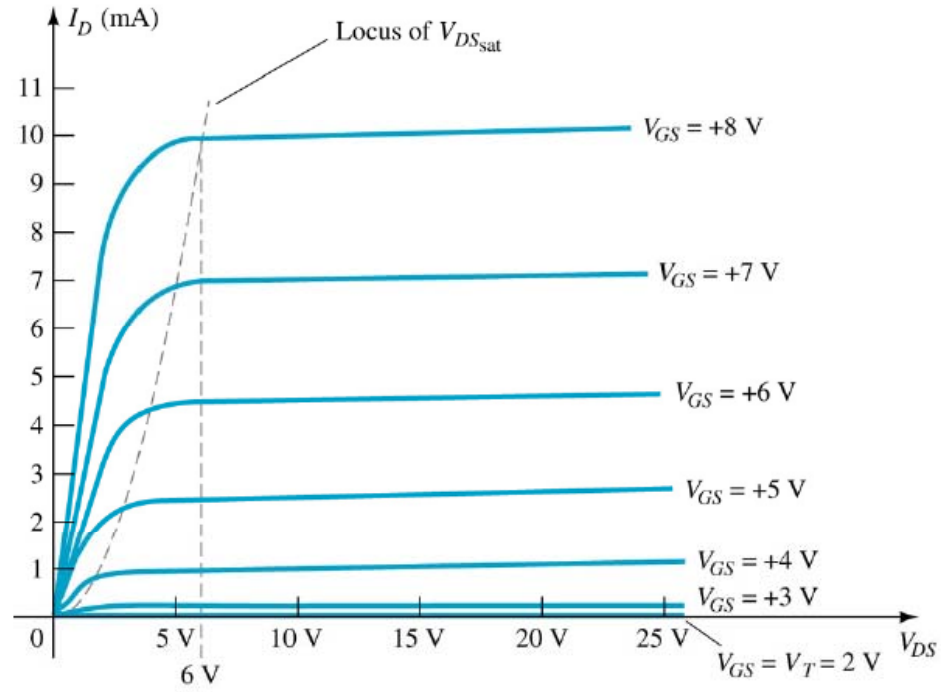
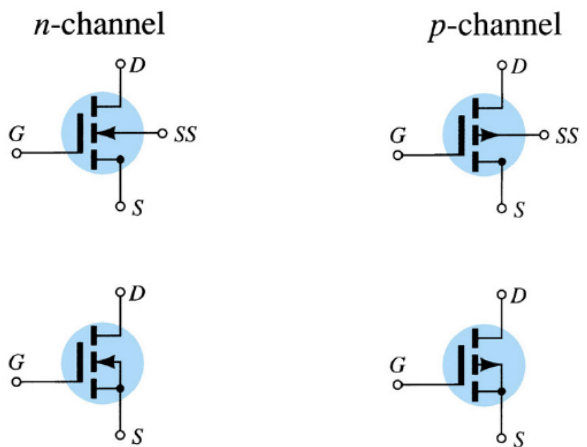
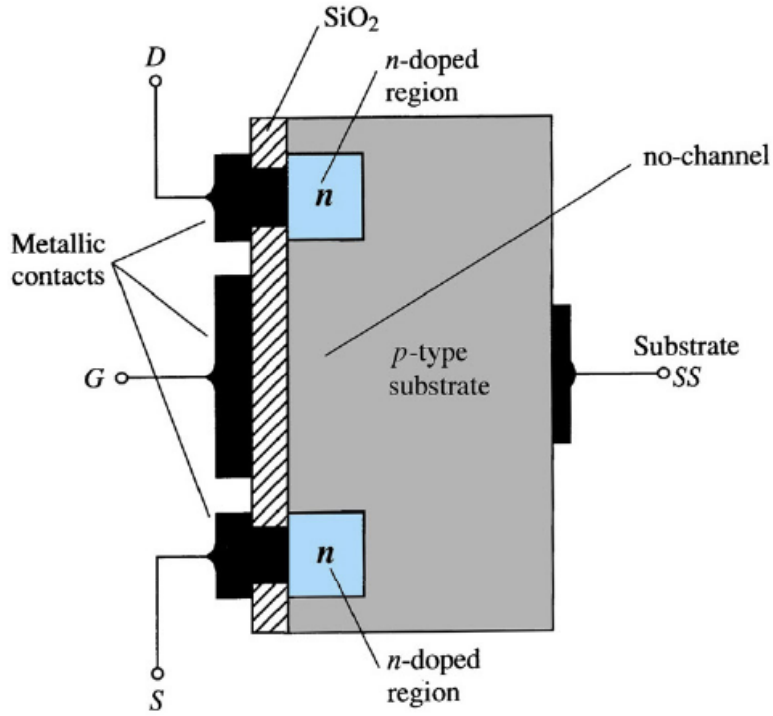

Canal n

MOSFET de potência

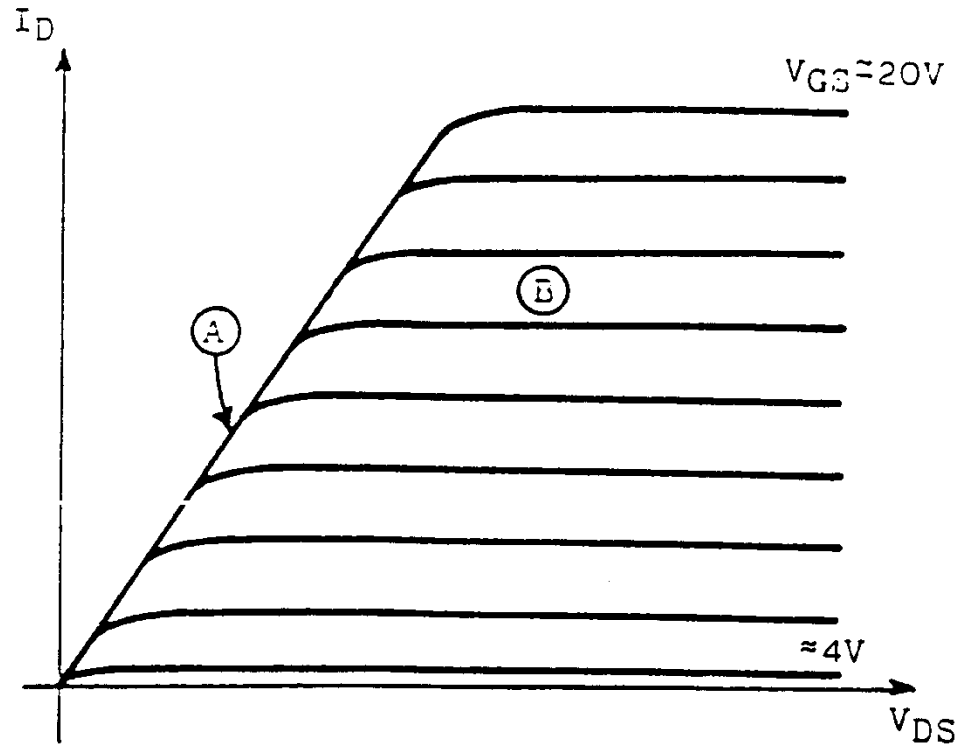
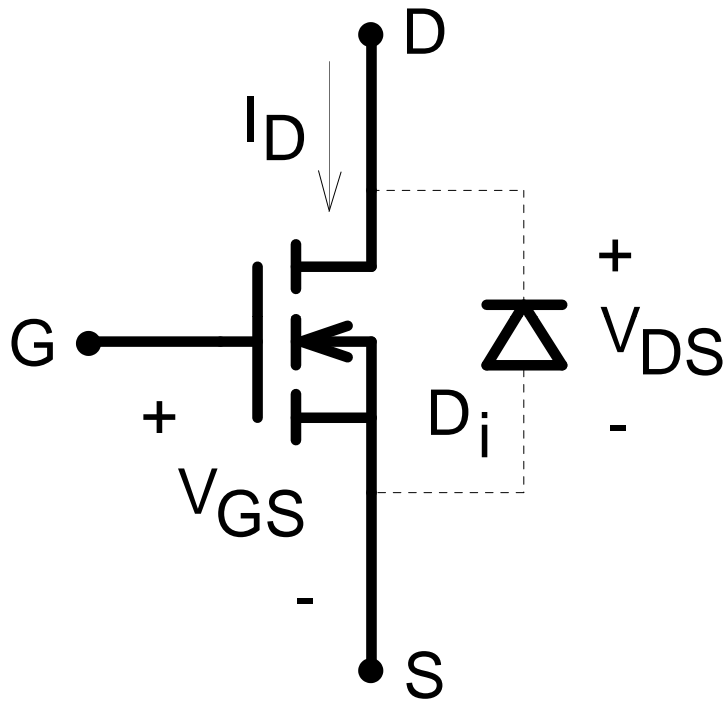

MOSFET de potência

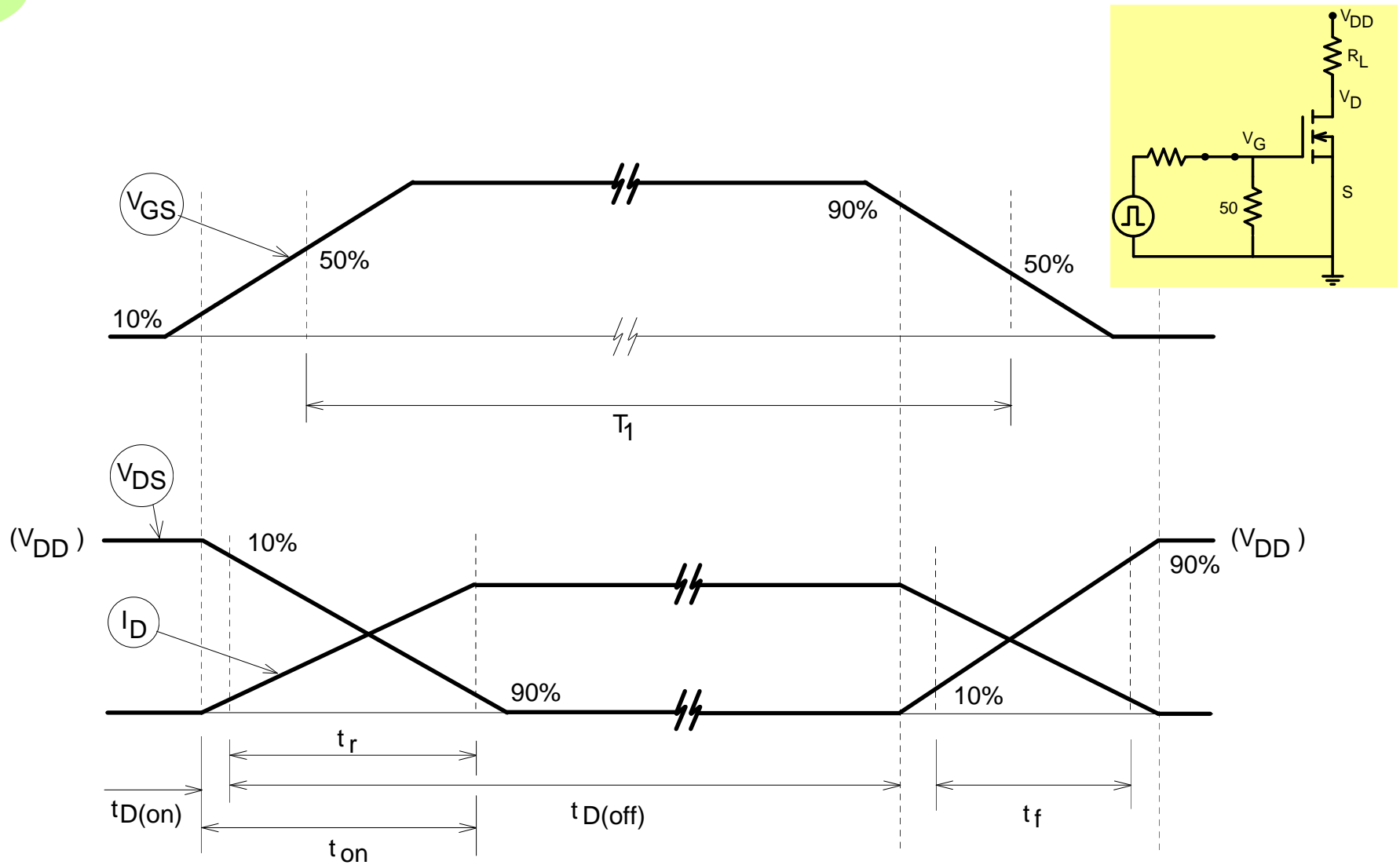

Comutação do MOSFET com carga resistiva

MOSFET de potência

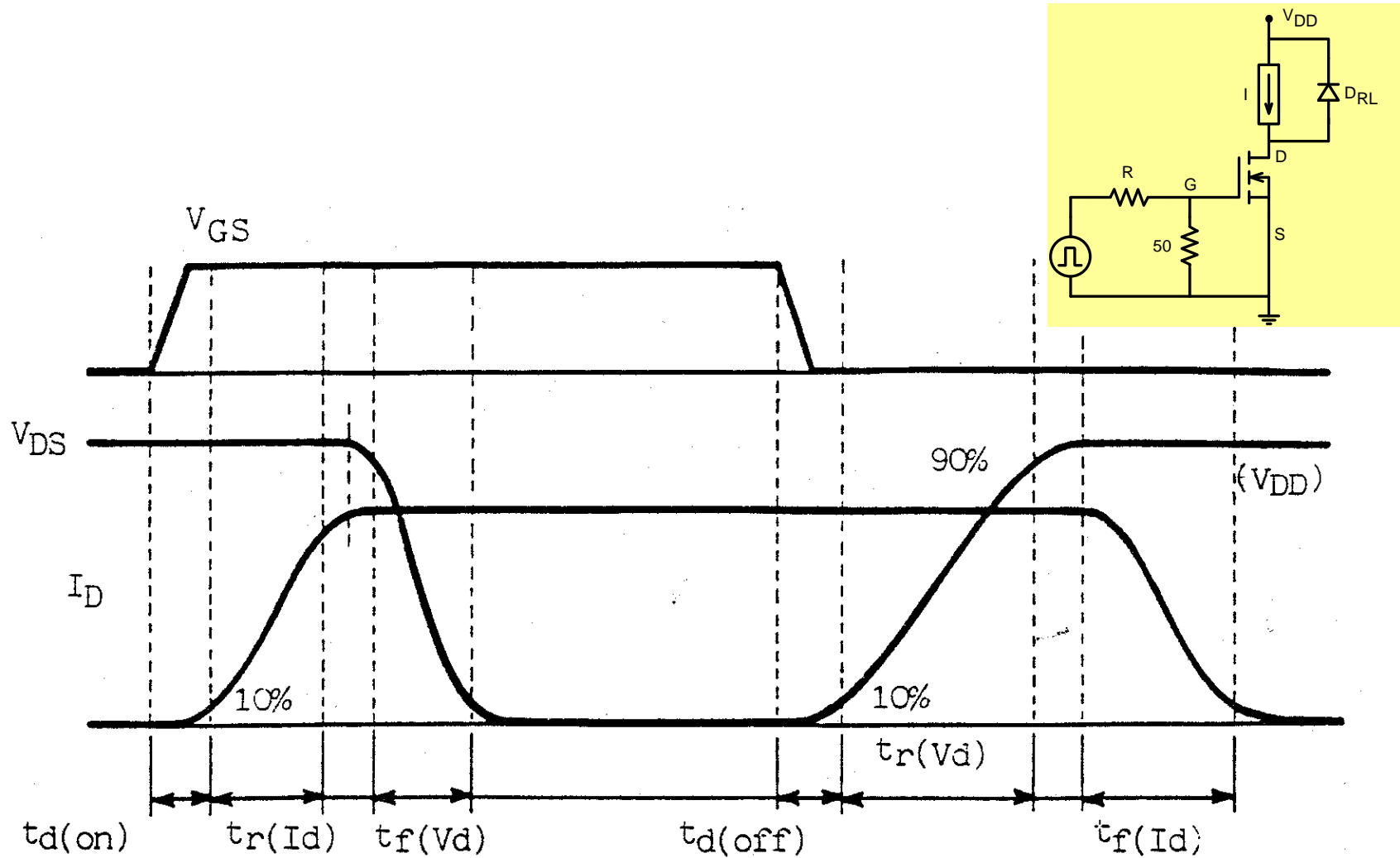

Comutação do MOSFET com carga indutiva

MOSFET de potência

Classificação das perdas:

1. Condução;

$$P_{cond} = \frac{t_{on}}{T} \cdot r_{ds(on)} \cdot i_{d(on)}^2$$

2. Comutação:

- Entrada em condução e bloqueio;

$$P_{com} = \frac{f}{2} (t_r + t_f) \cdot i_{d(on)} \cdot v_{ds(off)}$$

- Onde:

$$t_f \cong t_{on}$$

$$t_r \cong t_{off}$$

MOSFET de potência

Dados de catalogo:

International
IR Rectifier

PD - 94459A

IRFP150V

HEXFET® Power MOSFET

- Advanced Process Technology
- Ultra Low On-Resistance
- Dynamic dV/dt Rating
- 175°C Operating Temperature
- Fast Switching
- Fully Avalanche Rated

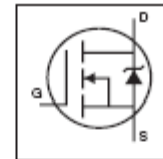

$V_{DS} = 100V$
 $R_{DS(on)} = 24m\Omega$
 $I_D = 47A$

Description

Advanced HEXFET® Power MOSFETs from International Rectifier utilize advanced processing techniques to achieve extremely low on-resistance per silicon area. This benefit, combined with the fast switching speed and ruggedized device design that HEXFET power MOSFETs are well known for, provides the designer with an extremely efficient and reliable device for use in a wide variety of applications.

The TO-247 package is preferred for commercial/Industrial applications where higher power levels preclude the use of TO-220 devices. The TO-247 is similar but superior to the earlier TO-218 package because of its isolated mounting hole.

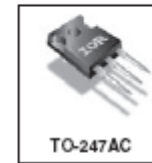

TO-247AC

Absolute Maximum Ratings

Parameter	Max.	Units
I_D @ $T_C = 25^\circ C$	45	A
I_D @ $T_C = 100^\circ C$	32	
I_{DM}	230	
P_D @ $T_C = 25^\circ C$	140	W
	0.91	W/°C
V_{GS}	± 20	V
I_{AS}	28	A
E_{AS}	20	nJ
dV/dt	5.8	V/ns
T_J	-55 to +175	°C
T_{STG}		
	300 (1.5mm from case)	
	10 lb-in (1.1Nm)	

Thermal Resistance

Parameter	Typ.	Max.	Units
$R_{\theta(jc)}$	—	1.1	°C/W
$R_{\theta(cs)}$	0.24	—	
$R_{\theta(ja)}$	—	40	

MOSFET de potência

Quando usar MOSFET:

1. Freqüências altas (acima de 50 kHz);
2. Tensões muito baixas (< 500 V);
3. Potências baixas (< 1 kW).

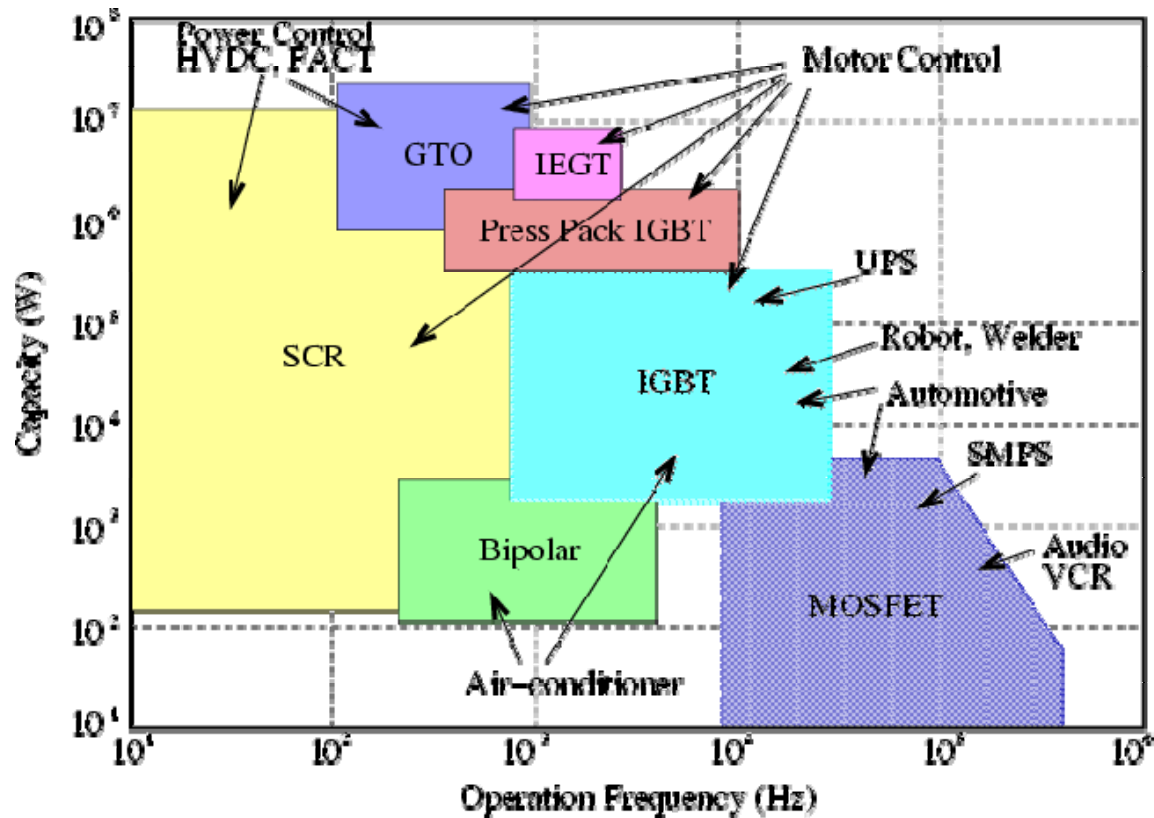

IGBT

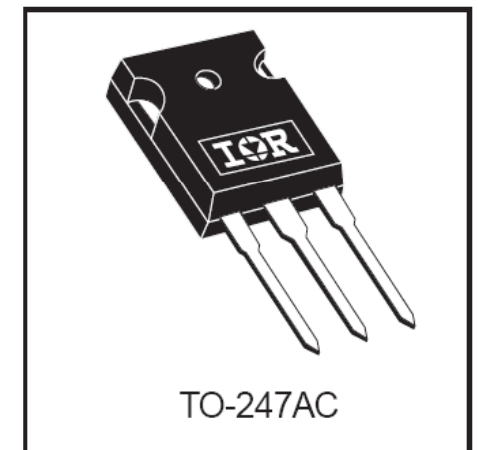
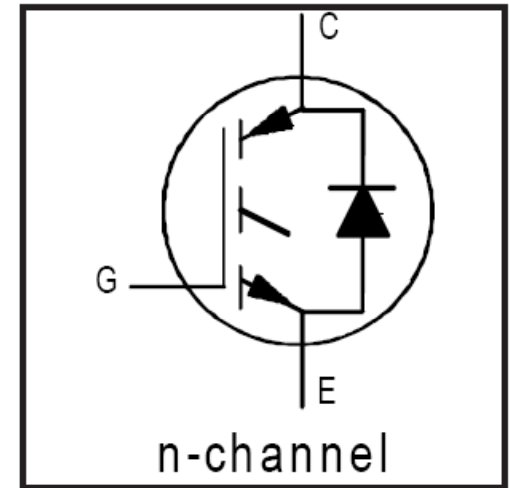
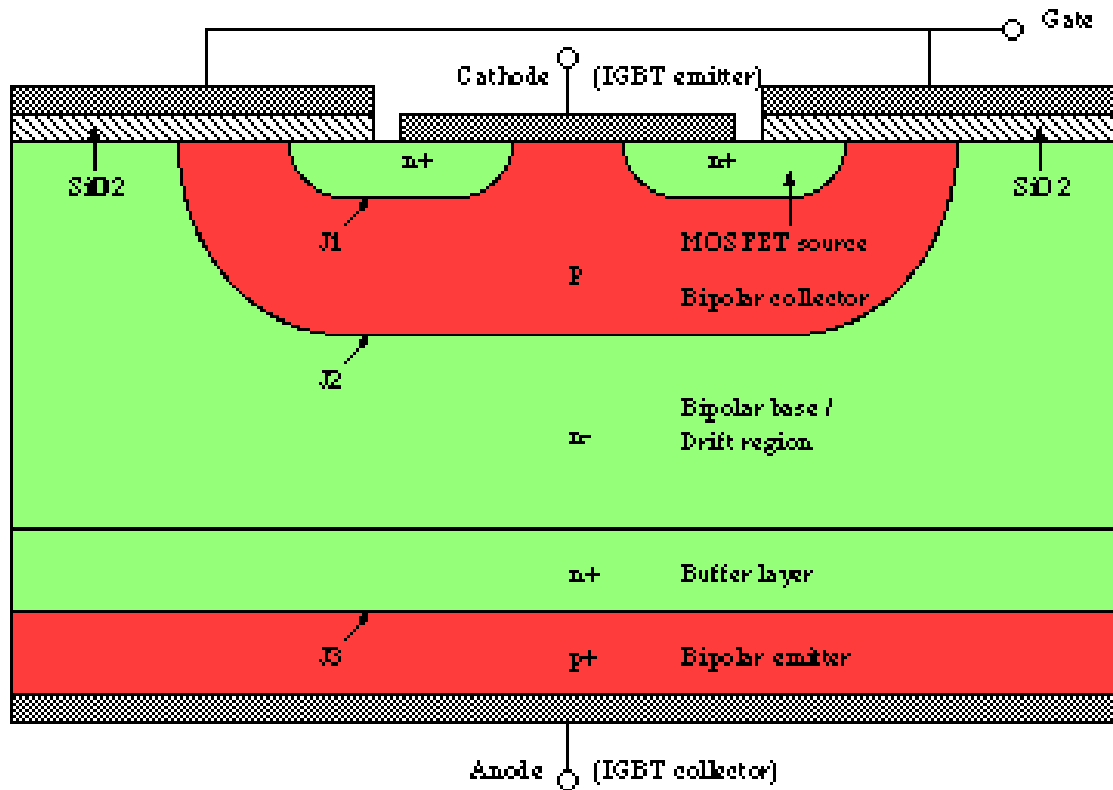

Características de BJT e MOSFET

IGBT – Insulated Gate Bipolar Transistor

IGBT

Classificação das perdas:

1. Condução;

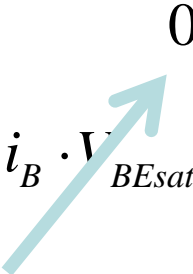
$$P_{cond} = (i_C \cdot V_{CEsat} + i_B \cdot V_{BEsat}) \cdot t_{on} \cdot f$$

2. Comutação:

- Entrada em condução e bloqueio;

$$P_{com} = \frac{1}{2} (t_r + t_f) \cdot I \cdot E \cdot f$$

Detalhamento do cálculo de perdas



IGBT

Quando usar IGBT:

1. Freqüências baixas (menor que 50 kHz);
2. Tensões altas (> 500 V);
3. Potências altas (> 1 kW).



Part	Family	Package	Circuit	Switching Speed
IRG4PH30K	IGBT Discretes	TO-247AC	Discrete	ULTRAFAST 4-20 kHz
IRG4PC20U	IGBT Discretes	TO-247AC	Discrete	ULTRAFAST 8-60 kHz
IRG4PC30S	IGBT Discretes	TO-247AC	Discrete	DC-1 kHz (STANDARD)
IRG4PC60U	IGBT Discretes	TO-247AC	Discrete	ULTRAFAST 8-60 kHz
IRG4BC30W	IGBT Discretes	TO-220AB	Discrete	WARP 60-150 kHz
IRGP20D60K	IGBT Discretes	TO-220AD	Discrete	ULTRAFAST 10-30 kHz
IRGBB60K	IGBT Discretes	TO-220AB	Discrete	ULTRAFAST 10-30 kHz
IRGS6B60K	IGBT Discretes	D2-Pak	Discrete	ULTRAFAST 10-30 kHz
IRGS14C40L	IGBT Discretes	D2-Pak	Discrete	Low-Vceon
IRGP4050	IGBT Discretes	TO-247AC	Discrete	Low-Vceon

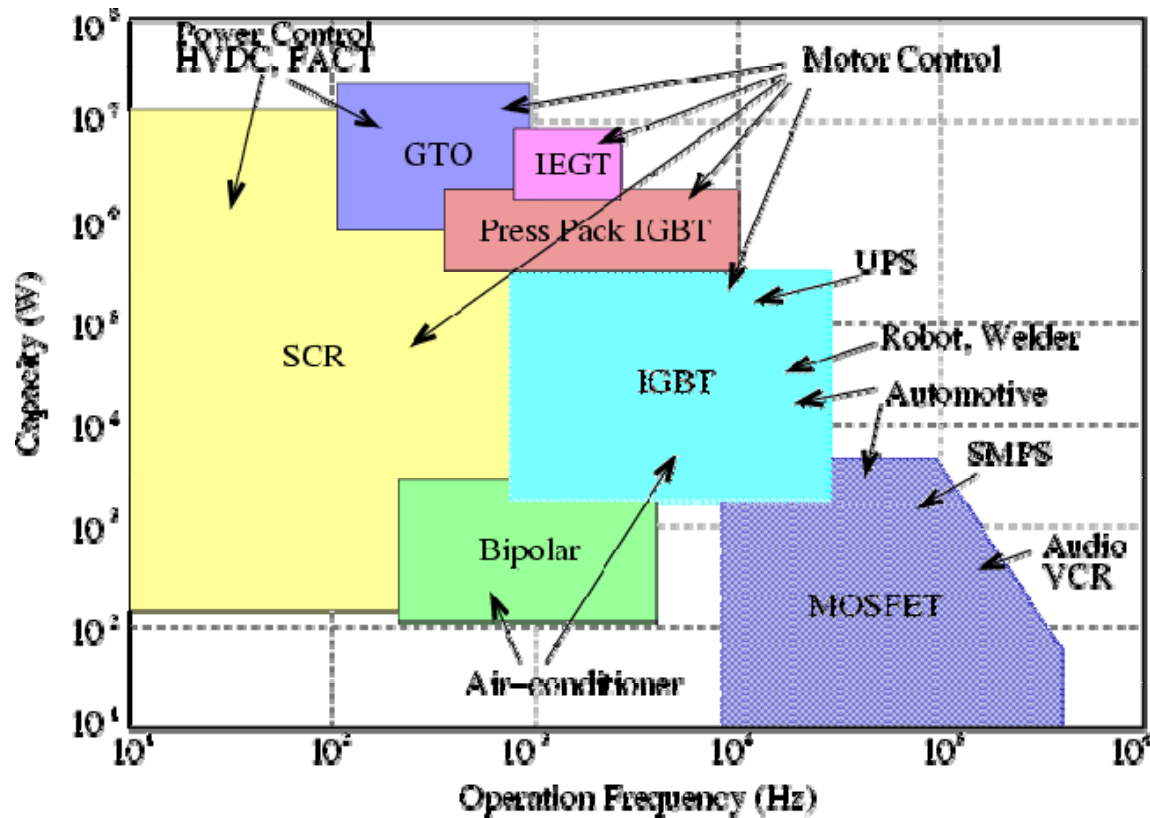

IGBT

Quando usar IGBT:

1. Freqüências baixas (menor que 50 kHz);
2. Tensões altas (> 500 V);
3. Potências altas (> 1 kW).

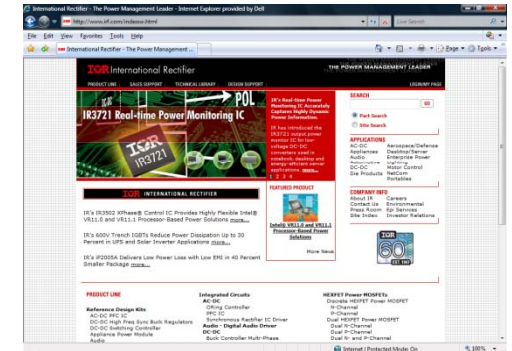

www.irf.com

Part	Family	Package	Circuit	Switching Speed	VCES (V)	VCE(ON) (V)	IC @ 25C (A)	IC @ 100C (A)	PD @25C (W)
IRG4PH30K	IGBT Discretes	TO-247AC	Discrete	ULTRAFAST 4-20 kHz	1200	4.20	20	10	100
IRG4PC20U	IGBT Discretes	TO-247AC	Discrete	ULTRAFAST 8-60 kHz	600	2.1	13	6.5	60
IRG4PC30S	IGBT Discretes	TO-247AC	Discrete	DC-1 kHz (STANDARD)	600	1.60	34	18	100
IRG4PC60U	IGBT Discretes	TO-247AC	Discrete	ULTRAFAST 8-60 kHz	600	2.00	75	40	520
IRG4BC30W	IGBT Discretes	TO-220AB	Discrete	WARP 60-150 kHz	600	2.70	23	12	100
IRGB30B60K	IGBT Discretes	TO-220AB	Discrete	ULTRAFAST 10-30 kHz	600	2.35	78	50	370
IRGB8B60K	IGBT Discretes	TO-220AB	Discrete	ULTRAFAST 10-30 kHz	600	2.2	17	9.0	140
IRGS6B60K	IGBT Discretes	D2-Pak	Discrete	ULTRAFAST 10-30 kHz	600	1.80	13	7	90
IRGS14C40L	IGBT Discretes	D2-Pak	Discrete	Low-Vceon	430	1.40	20	14	125
IRGP4050	IGBT Discretes	TO-247AC	Discrete	Low-Vceon	250	1.90	104	56	330

IGBT

Encapsulamentos:



www.semikron.com.br



IGBT

Encapsulamentos:



D-PAK
TO-252AA



TO-220AB
IRGB6B60K



D²Pak
IRGS6B60K



TO-262
IRGSL6B60K

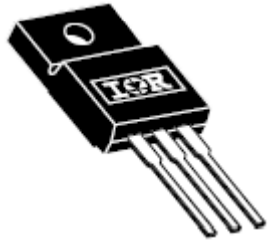

TO-220 FULLPAK

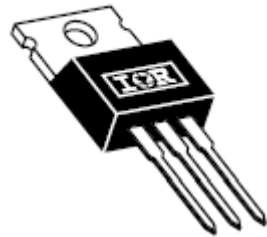

TO-220AB

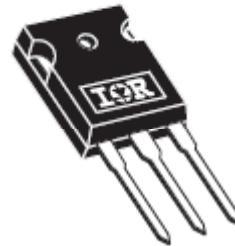

TO-247AC



TO-247AC

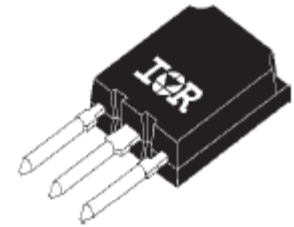

SUPER - 247



www.irf.com

Dados de catalogo:

International
IR Rectifier

INSULATED GATE BIPOLAR TRANSISTOR

PD - 94443

IRG4PC60U

UltraFast Speed IGBT

Features

- UltraFast: Optimized for high operating frequencies up to 50 kHz in hard switching, >200 kHz in resonant mode.
- Generation 4 IGBT design provides tighter parameter distribution and higher efficiency.
- Industry standard TO-247AC package.

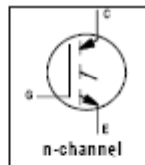

$V_{CES} = 600V$
 $V_{CE(sat) typ.} = 1.6V$
@ $V_{GE} = 15V, I_C = 40A$

Benefits

- Generation 4 IGBT's offer highest efficiency available.
- IGBT's optimized for specified application conditions.
- Designed for best performance when used with IR Hexfred & IR Fred companion diodes.



TO-247AC

Absolute Maximum Ratings

Parameter	Max.	Units
V_{CES}	600	V
$I_C @ T_C = 25^\circ C$	75	A
$I_C @ T_C = 100^\circ C$	40	
I_{CM}	300	
I_{CLM}	300	A
I_{SM}	300	
V_{GE}	± 20	V
E_{ASV}	200	mJ
$P_D @ T_C = 25^\circ C$	520	W
$P_D @ T_C = 100^\circ C$	210	
T_J	-55 to $+150$	°C
T_{STG}		
T_{SOL}	350 (0.063 in. (1.6mm) from case)	
	10 lbf-in (1.1Nm)	

Thermal Resistance

Parameter	Typ.	Max.	Units
$R_{\theta JC}$	---	0.24	°C/W
$R_{\theta CS}$	0.24	---	
$R_{\theta JA}$	---	40	
Wt	8 (0.21)	---	g (oz)

www.irf.com

1
042902

International
IR Rectifier

INSULATED GATE BIPOLAR TRANSISTOR WITH
ULTRAFAST SOFT RECOVERY DIODE

PD 9.1467D

IRG4PC40UD

UltraFast CoPack IGBT

Features

- UltraFast: Optimized for high operating frequencies 8-40 kHz in hard switching, >200 kHz in resonant mode.
- Generation 4 IGBT design provides tighter parameter distribution and higher efficiency than Generation 3
- IGBT co-packaged with HEXFRED™ ultrafast, ultra-soft-recovery anti-parallel diodes for use in bridge configurations
- Industry standard TO-247AC package

Benefits

- Generation -4 IGBT's offer highest efficiencies available
- IGBT's optimized for specific application conditions
- HEXFRED diodes optimized for performance with IGBT's. Minimized recovery characteristics require less snubbing
- Designed to be a "drop-in" replacement for equivalent industry-standard Generation 3 IR IGBT's

Absolute Maximum Ratings

Parameter	Max.	Units
V_{CES}	600	V
$I_C @ T_C = 25^\circ C$	40	A
$I_C @ T_C = 100^\circ C$	20	
I_{CM}	160	
I_{CLM}	160	A
I_{SM}	160	
$I_D @ T_C = 100^\circ C$	15	A
I_{SM}	160	
V_{GE}	± 20	V
$P_D @ T_C = 25^\circ C$	160	W
$P_D @ T_C = 100^\circ C$	65	
T_J	-55 to $+150$	°C
T_{STG}		
T_{SOL}	320 (0.063 in. (1.6mm) from case)	
	10 lbf-in (1.1 Nm)	

Thermal Resistance

Parameter	Min.	Typ.	Max.	Units
$R_{\theta JC}$	---	---	0.77	°C/W
$R_{\theta CS}$	---	---	1.7	
$R_{\theta JA}$	---	0.24	---	
$R_{\theta JA}$	---	---	40	g (oz)
Wt	---	8 (0.21)	---	

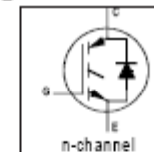

$V_{CES} = 600V$
 $V_{CE(sat) typ.} = 1.72V$
@ $V_{GE} = 15V, I_C = 20A$

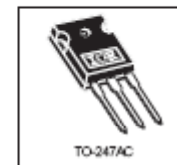

TO-247AC

BJT x MOSFET x IGBT

	MOSFET	IGBT	BJT
Tipo de comando	Tensão	Tensão	Corrente
Potência do comando	Mínima	Mínima	Grande
Complexidade do comando	Simples	Simples	Média
Densidade de corrente	Elevada em baixas tensões e Baixa em altas tensões	Muito elevada	Média
Perdas de comutação	Muito baixa	Baixa para Média	Média para Alta

Próxima aula

Conversores CA-CA:

1. Gradadores.

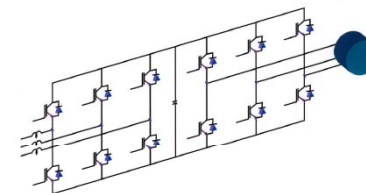
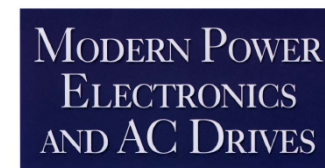
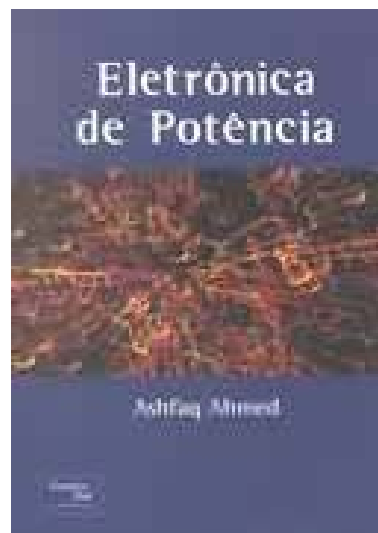
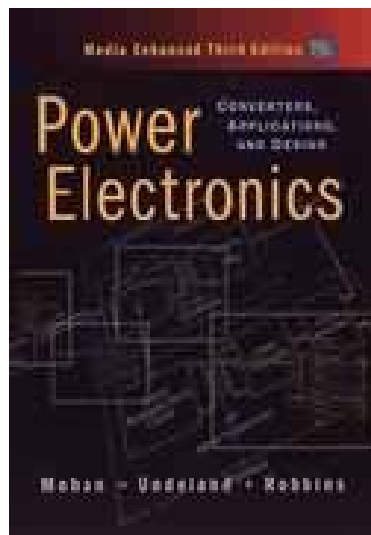

www.cefetsc.edu.br/~petry