

Centro Federal de Educação Tecnológica de Santa Catarina
Departamento Acadêmico de Eletrônica
Conversores Estáticos

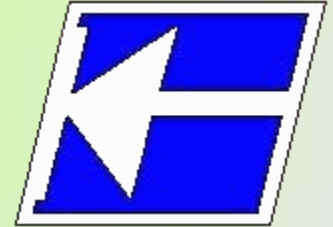

Conversores CC-CC Não-Isolados
Estágio de Potência dos Conversores
Boost e Buck-Boost

Prof. Clóvis Antônio Petry.

Florianópolis, outubro de 2008.

Bibliografia para esta aula

Capítulo 9: Choppers DC

1. Conversores CC-CC não-isolados.

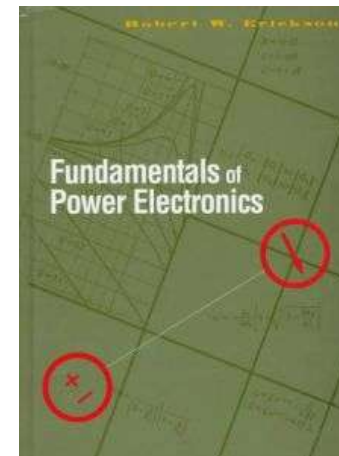

Nesta aula

Conversores CC-CC:

1. Revisão do conversor Buck;
2. Conversor Boost;
3. Conversor Buck-Boost;
4. Outros conversores básicos.

Conversor Buck

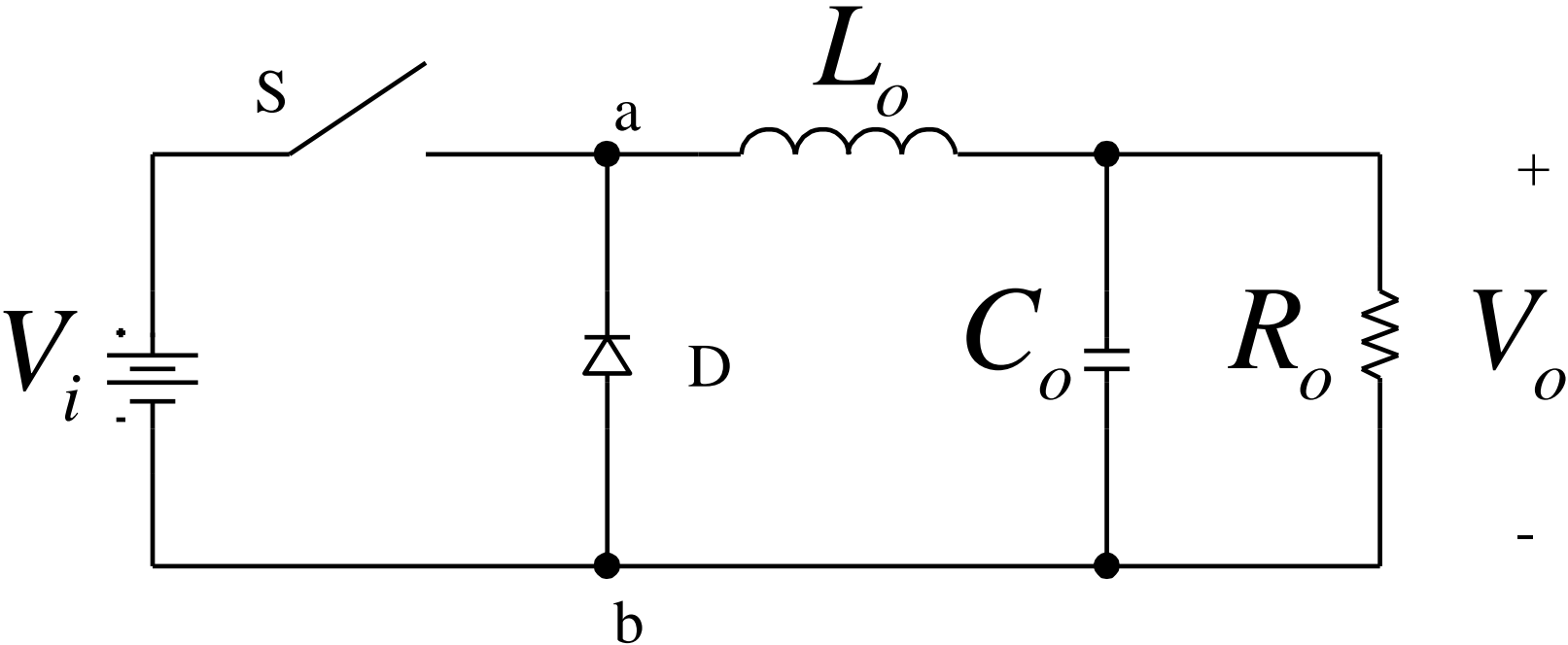

Conversor Buck

Primeira etapa de funcionamento:

- Interruptor conduzindo;
- Diodo bloqueado;
- Energia sendo armazenada no indutor.

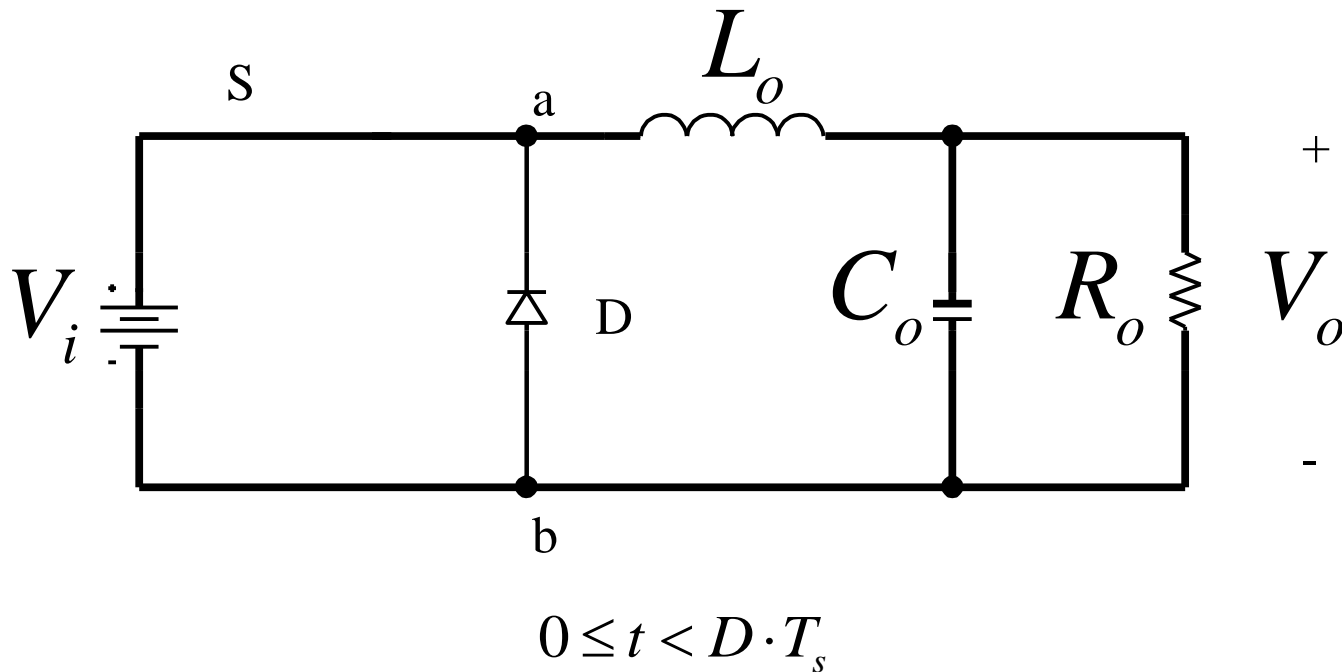

Conversor Buck

Segunda etapa de funcionamento:

- Interruptor bloqueado;
- Diodo conduzindo;
- Energia armazenada no indutor sendo transferida para saída.

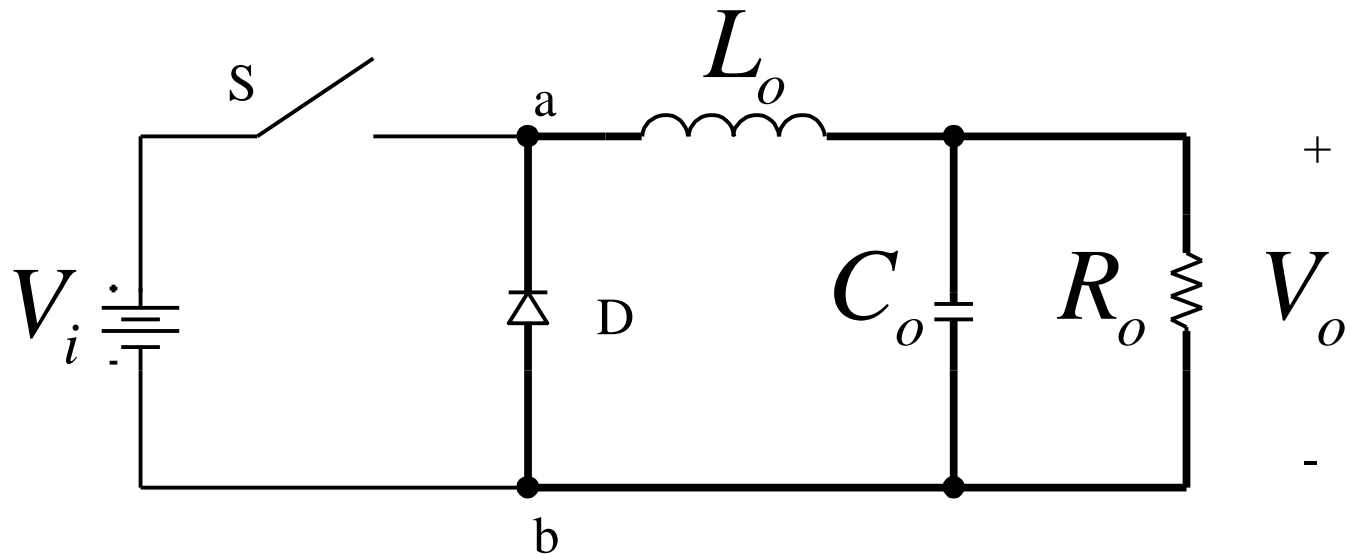

$$D \cdot T_s \leq t < T_s$$

Conversor Buck

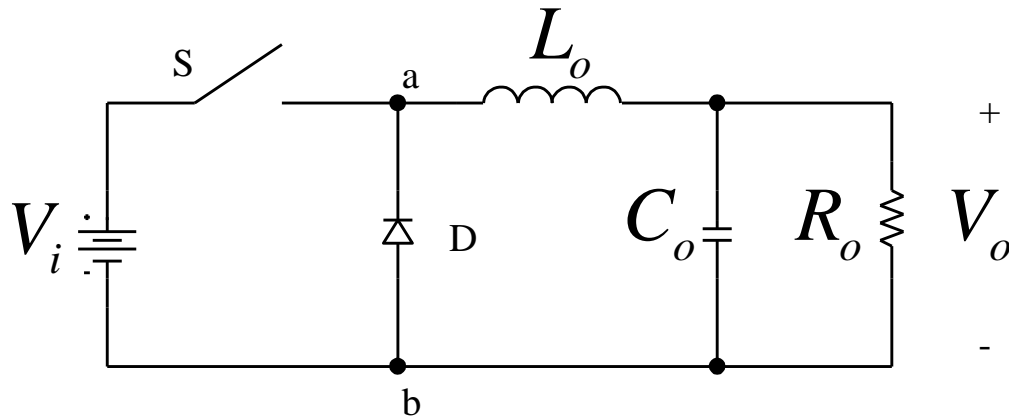

$$V_{ab} = \frac{1}{T_s} \int_0^{T_{on}} V_i \cdot dt = V_i \frac{T_{on}}{T_s}$$

$$V_{ab} = D \cdot V_i$$

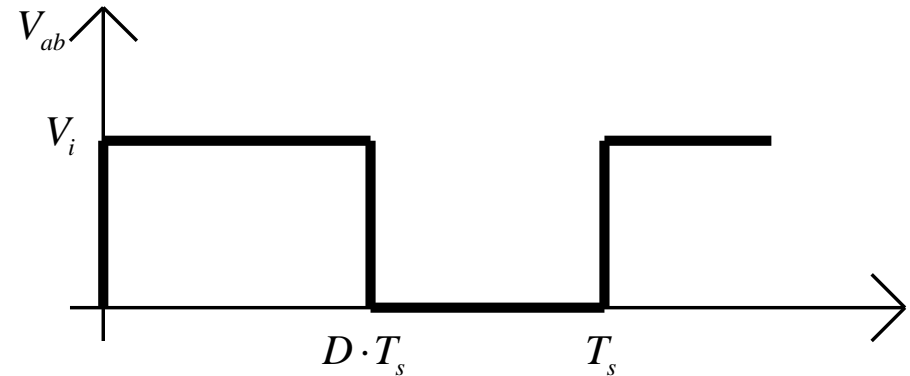

Conversor Buck

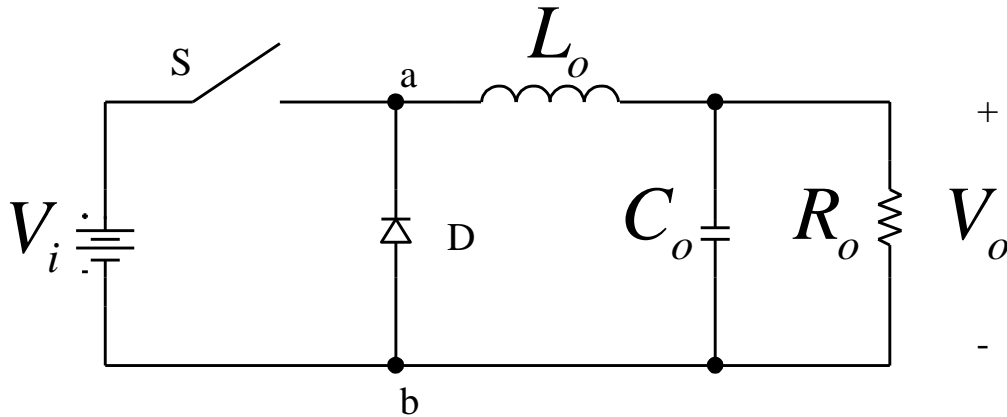

$$V_{ab} = \frac{1}{T_s} \int_0^{T_{on}} V_i \cdot dt = V_i \frac{T_{on}}{T_s}$$

$$V_{ab} = D \cdot V_i$$

$$V_o = V_{ab}$$

$$V_o = D \cdot V_i$$

$$D = \frac{V_o}{V_i}$$

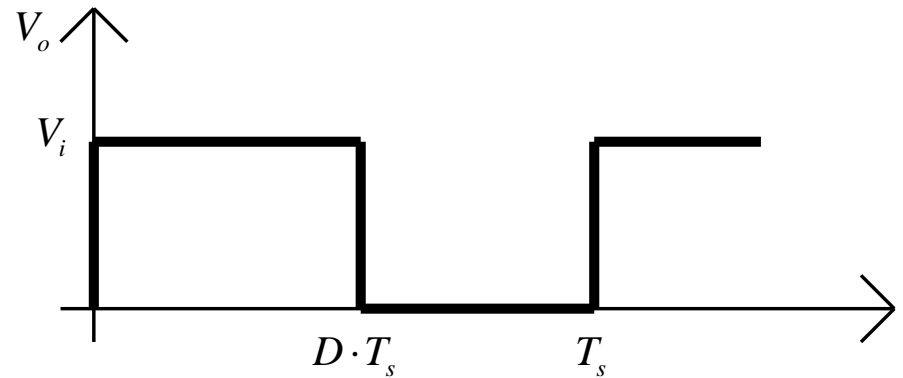

Conversor Buck

Ganho estático em função da razão cíclica:

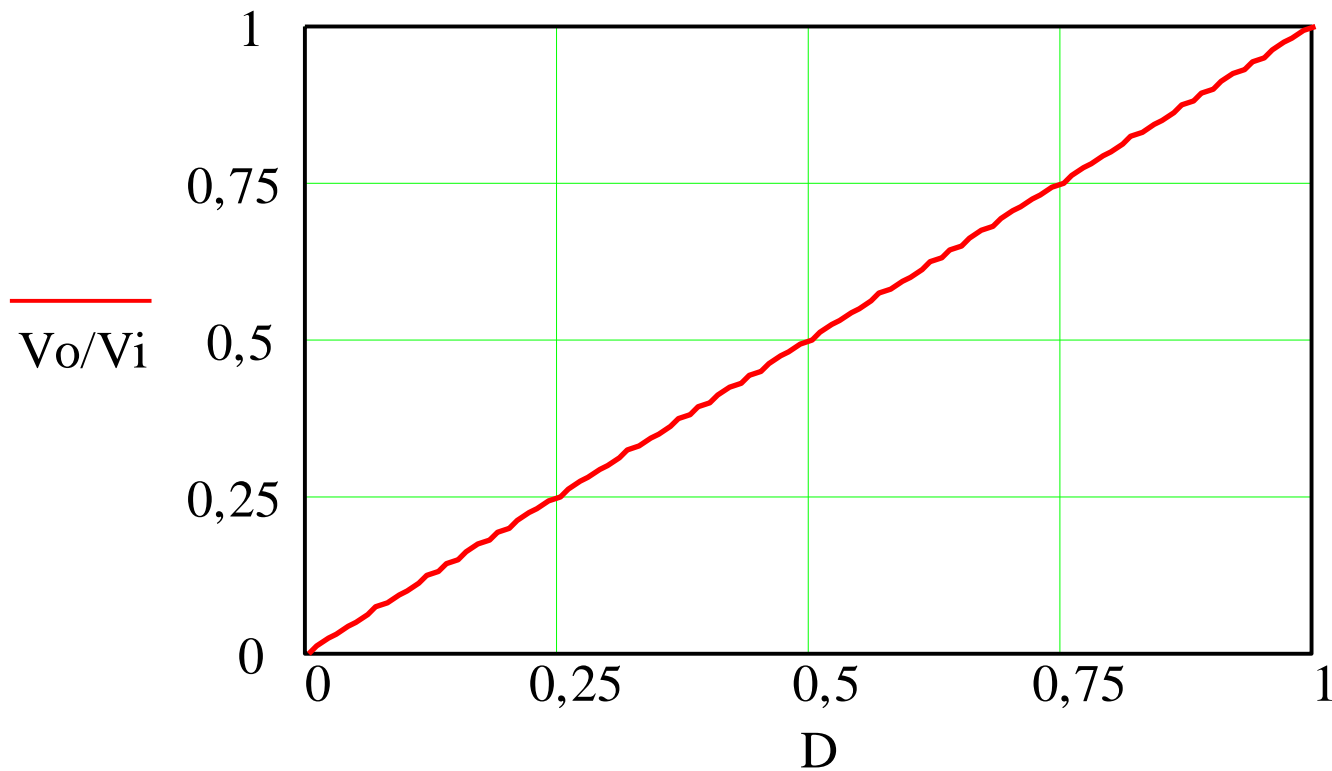

Converter Boost

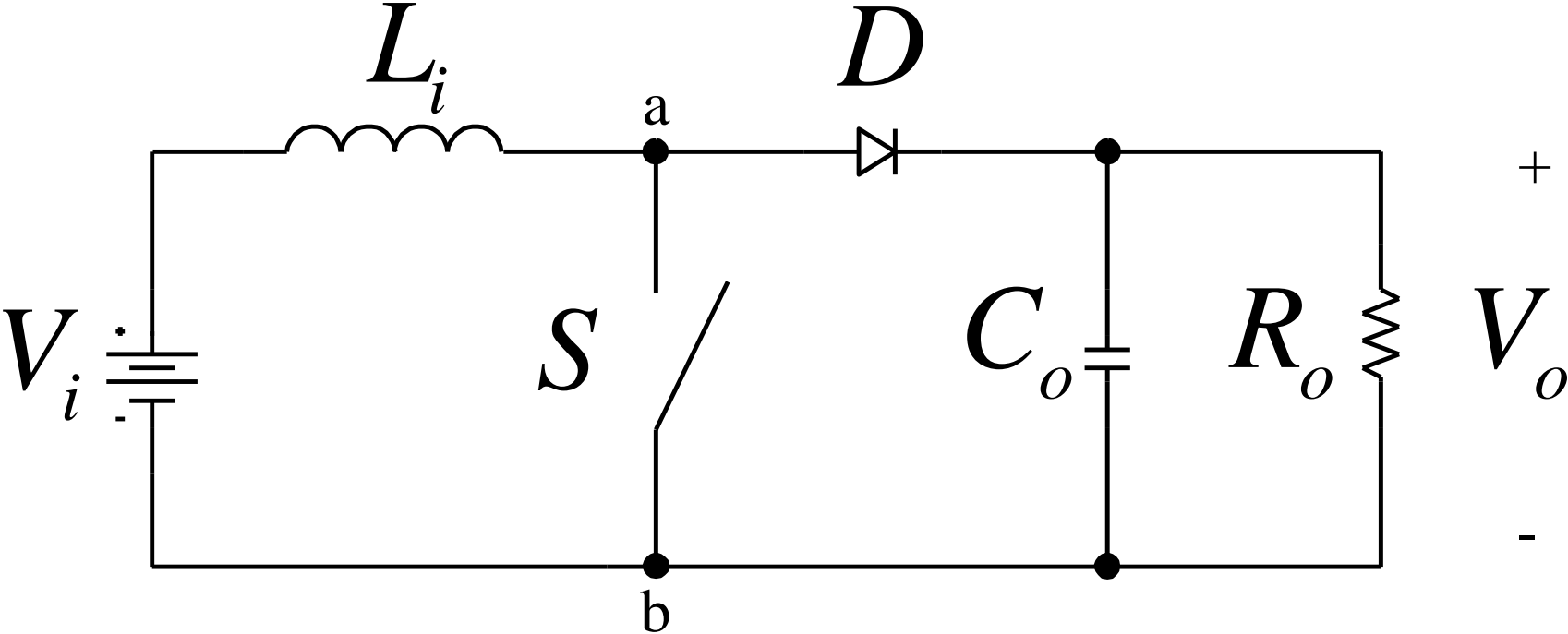

Conversor Boost

Primeira etapa de funcionamento:

- Interruptor conduzindo;
- Diodo bloqueado;
- Energia sendo armazenada no indutor.

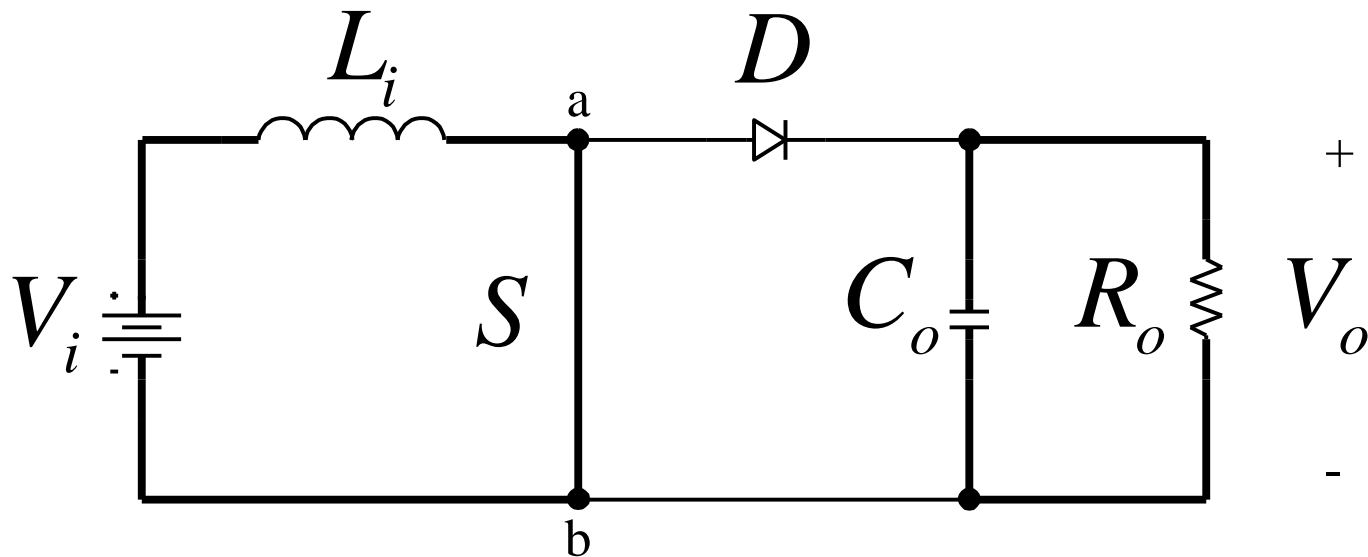

$$0 \leq t < D \cdot T_s$$

Conversor Boost

Segunda etapa de funcionamento:

- Interruptor bloqueado;
- Diodo conduzindo;
- Energia armazenada no indutor sendo transferida para saída.

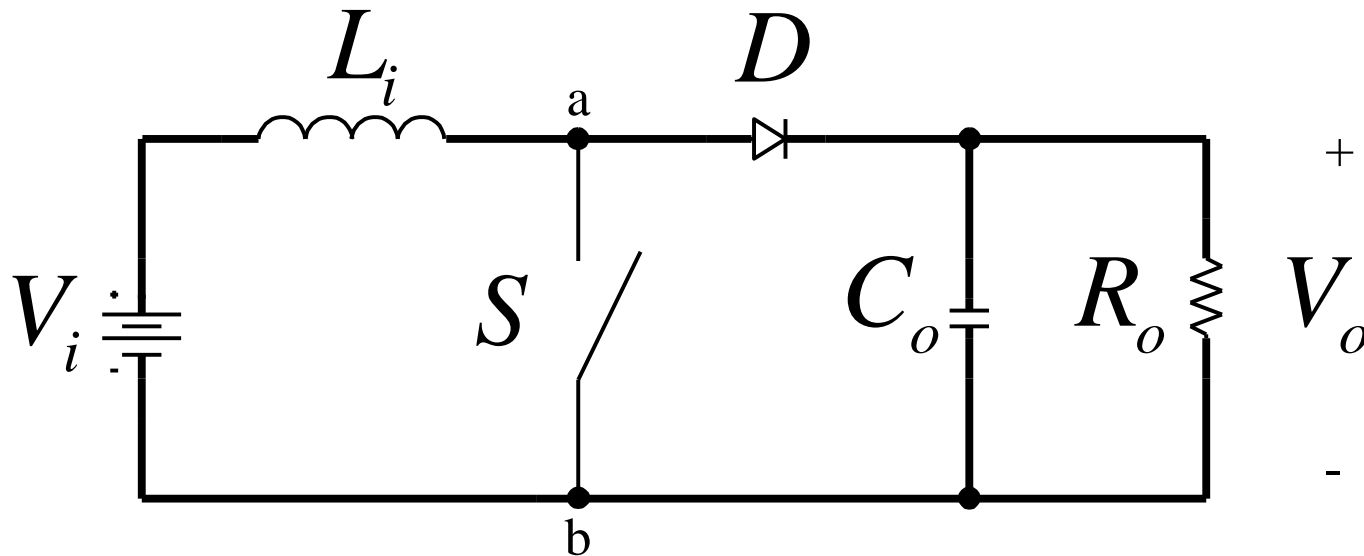

$$D \cdot T_s \leq t < T_s$$

Converter Boost

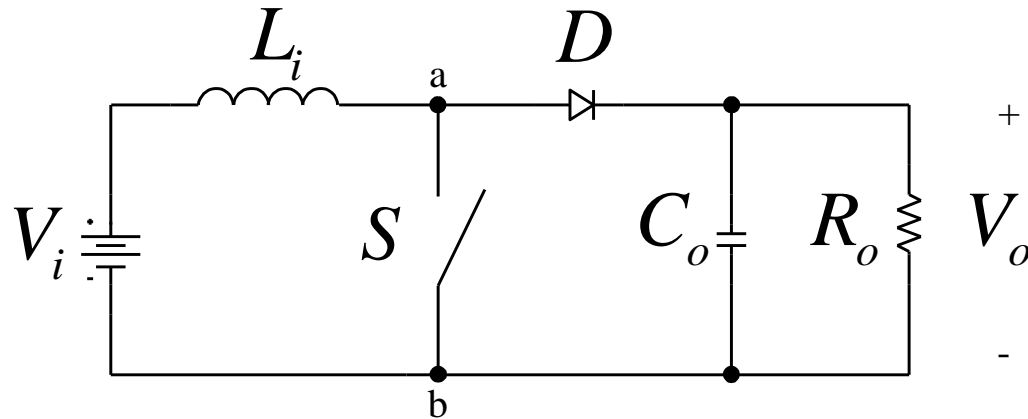

$$V_{ab} = \frac{1}{T_s} \int_{D \cdot T_s}^{T_s} V_o \cdot dt = V_o \frac{(T_s - D \cdot T_s)}{T_s}$$

$$V_{ab} = V_o (1 - D)$$

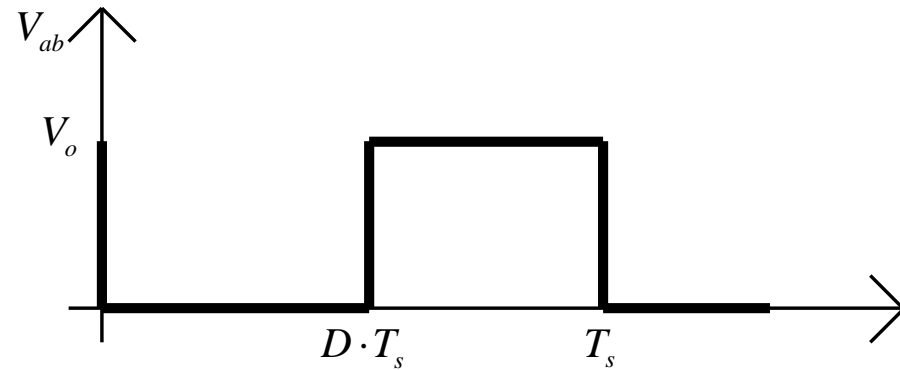

Converter Boost

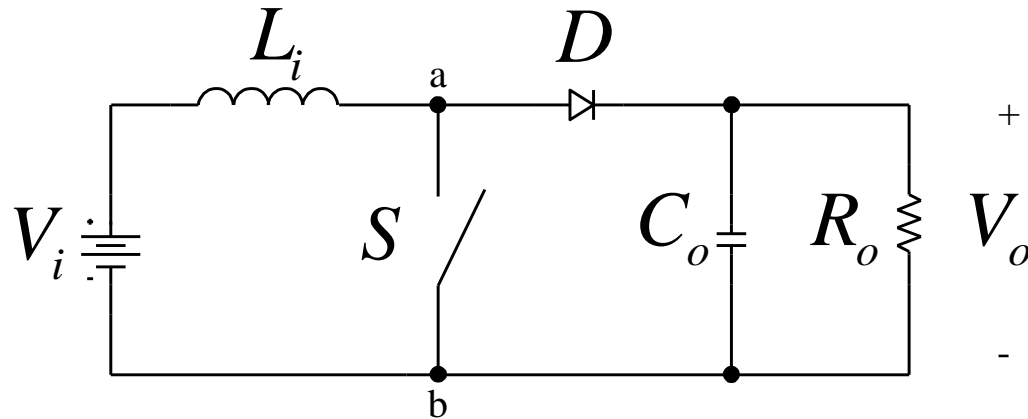

$$V_{ab} = \frac{1}{T_s} \int_{D \cdot T_s}^{T_s} V_o \cdot dt = V_o \frac{(T_s - D \cdot T_s)}{T_s}$$

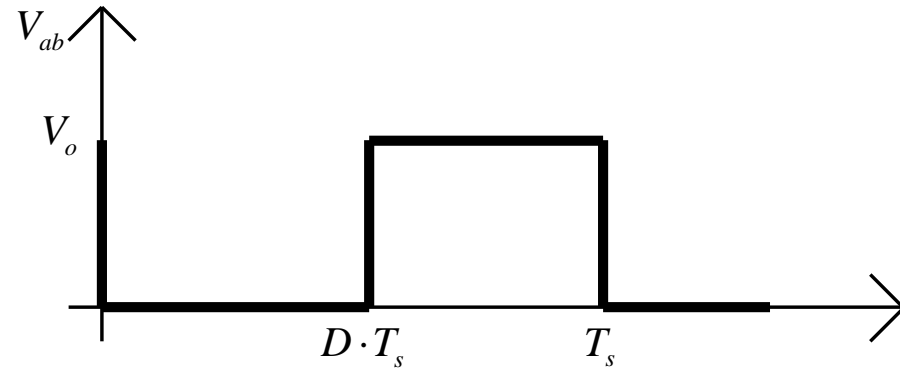

$$V_{ab} = V_o (1 - D)$$

$$V_{ab} = V_i$$

$$V_o = \frac{V_i}{1 - D}$$

$$D = 1 - \frac{V_i}{V_o}$$

Conversor Boost

Ganho estático em função da razão cíclica:

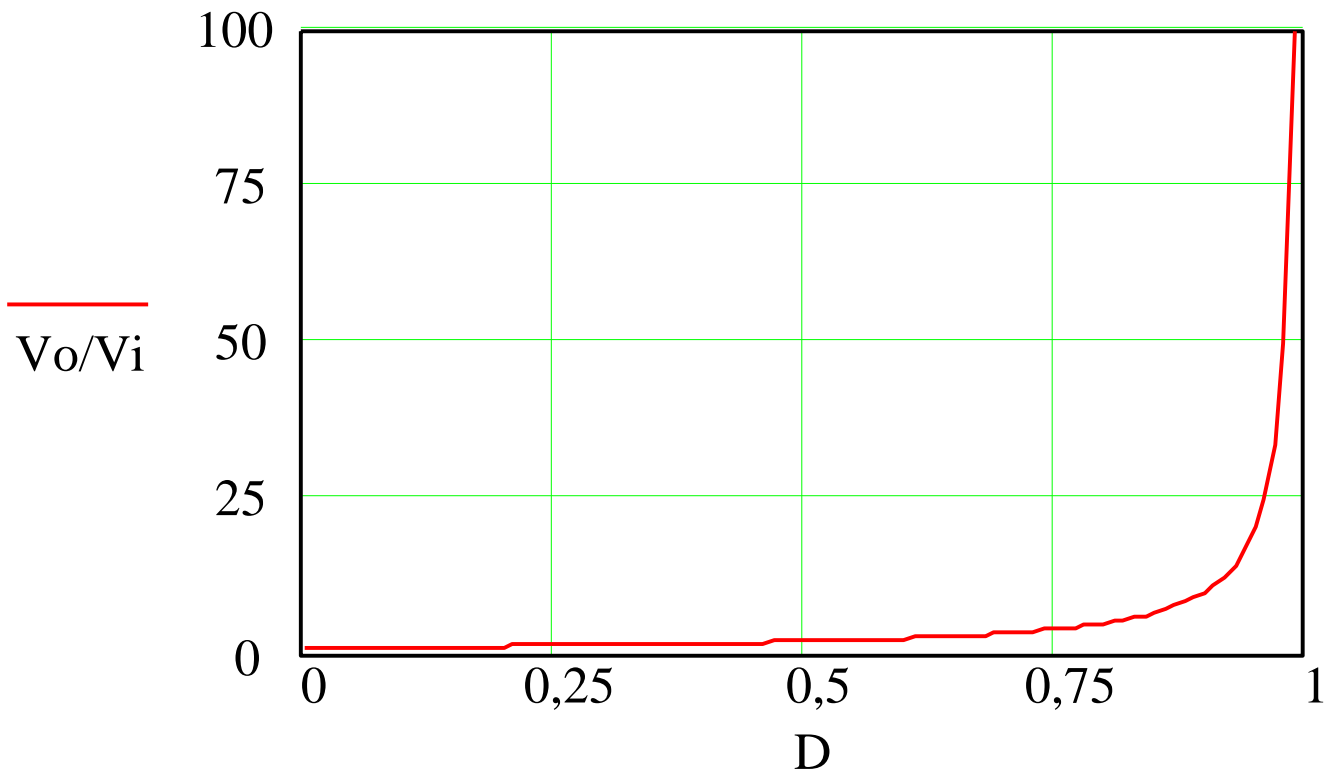

Conversor Boost

Elementos passivos:

$$\Delta I_{Li} = \frac{V_i}{L_i \cdot F_s} \cdot D$$

$$I_{Li} = \frac{V_i}{R_o} \cdot \frac{1}{(1-D)^2}$$

$$\Delta V_{Co} = \frac{I_o}{C_o \cdot F_s} \cdot \frac{V_o - V_i}{V_o}$$

Converter Buck-Boost

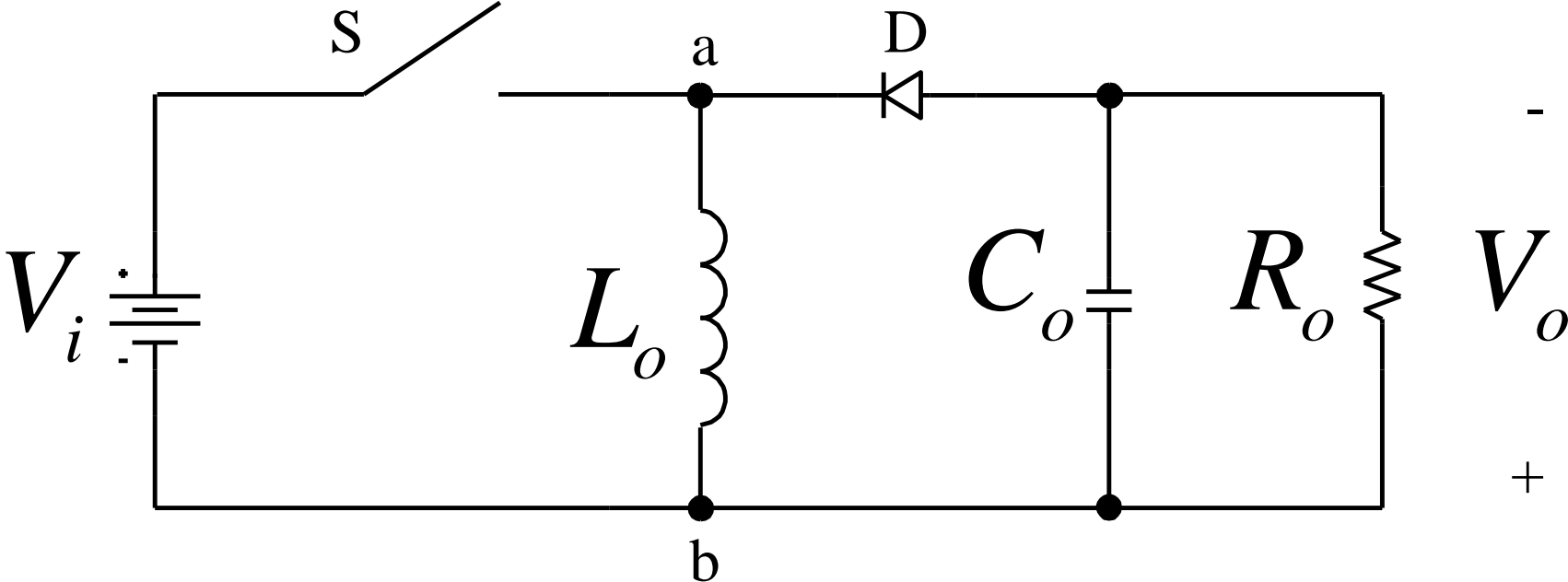

Conversor Buck-Boost

Primeira etapa de funcionamento:

- Interruptor conduzindo;
- Diodo bloqueado;
- Energia sendo armazenada no indutor.

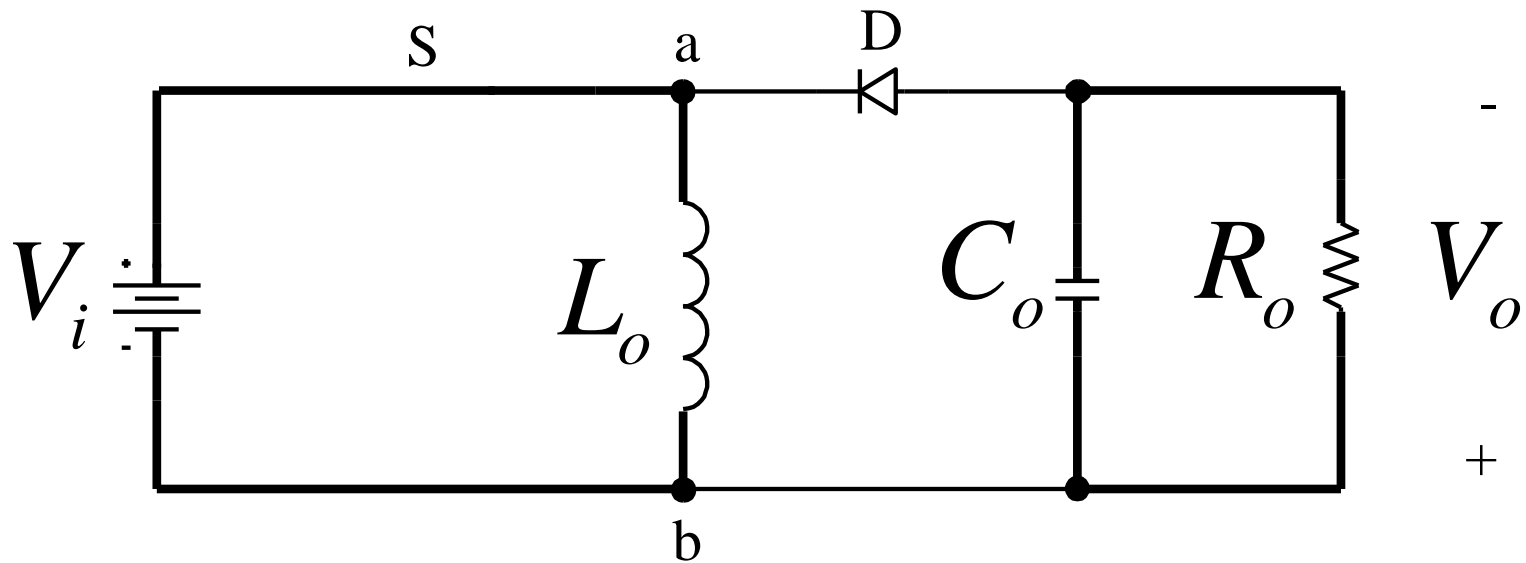

$$0 \leq t < D \cdot T_s$$

Conversor Buck-Boost

Segunda etapa de funcionamento:

- Interruptor bloqueado;
- Diodo conduzindo;
- Energia armazenada no indutor sendo transferida para saída.

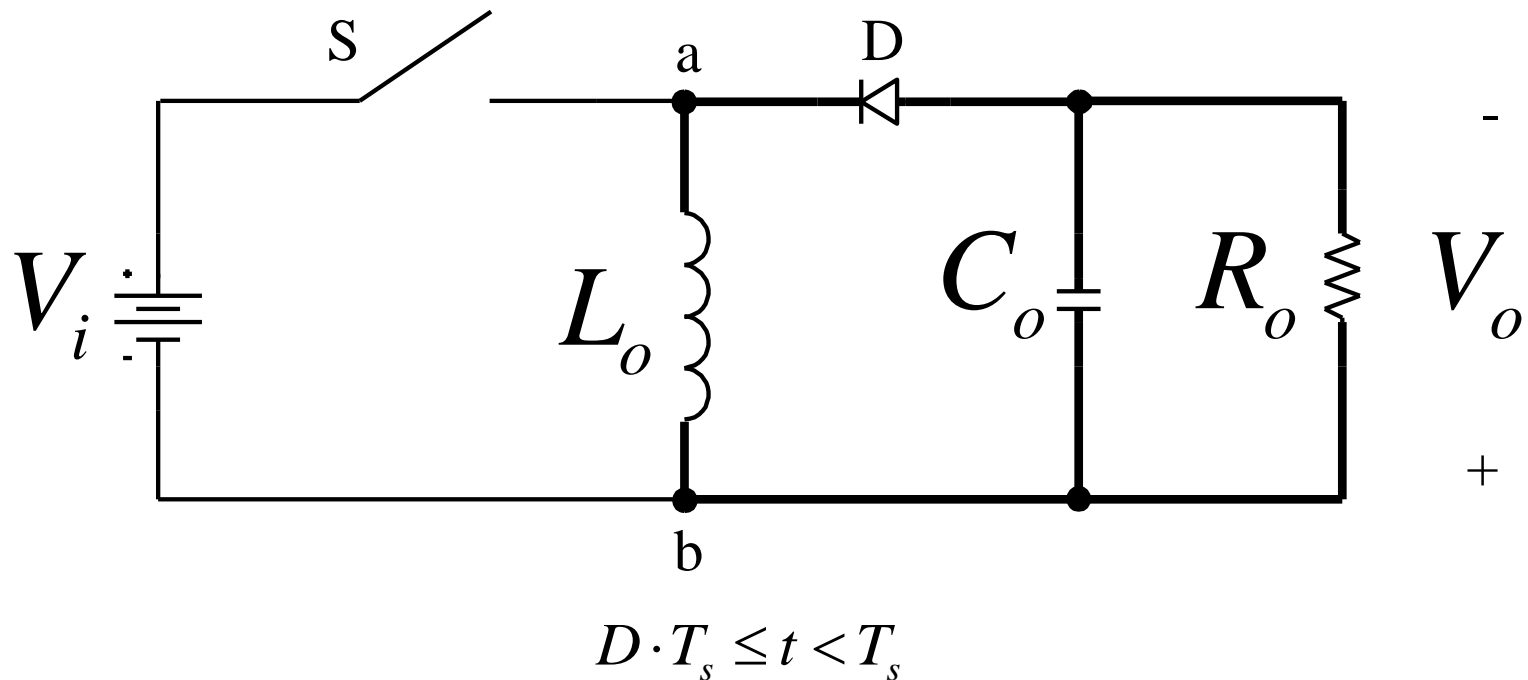

Converter Buck-Boost

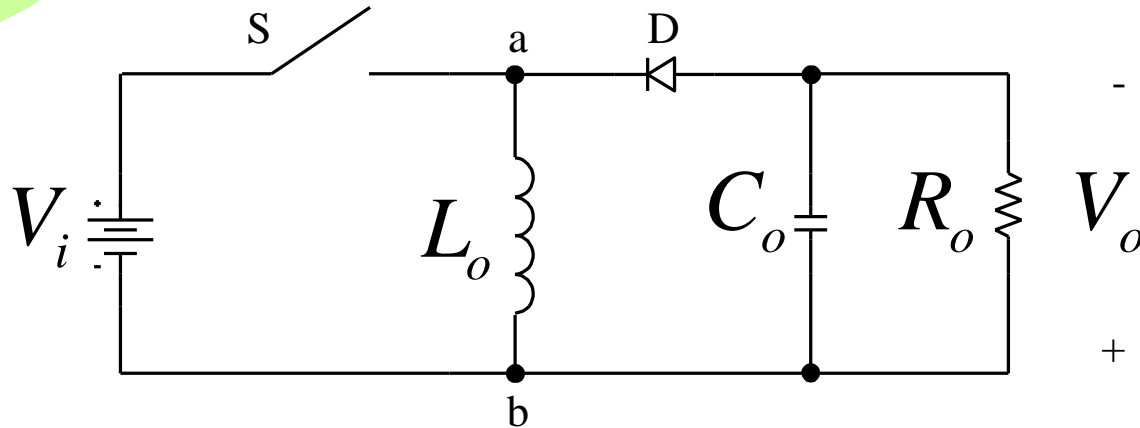

$$V_{ab} = \frac{1}{T_s} \int_0^{D \cdot T_s} V_i \cdot dt + \frac{1}{T_s} \int_{D \cdot T_s}^{T_s} (-V_o) \cdot dt$$

$$V_{ab} = \frac{V_i \cdot (D \cdot T_s - 0) - V_o \cdot (T_s - D \cdot T_s)}{T_s}$$

$$V_{ab} = V_i \cdot D - V_o \cdot (1 - D)$$

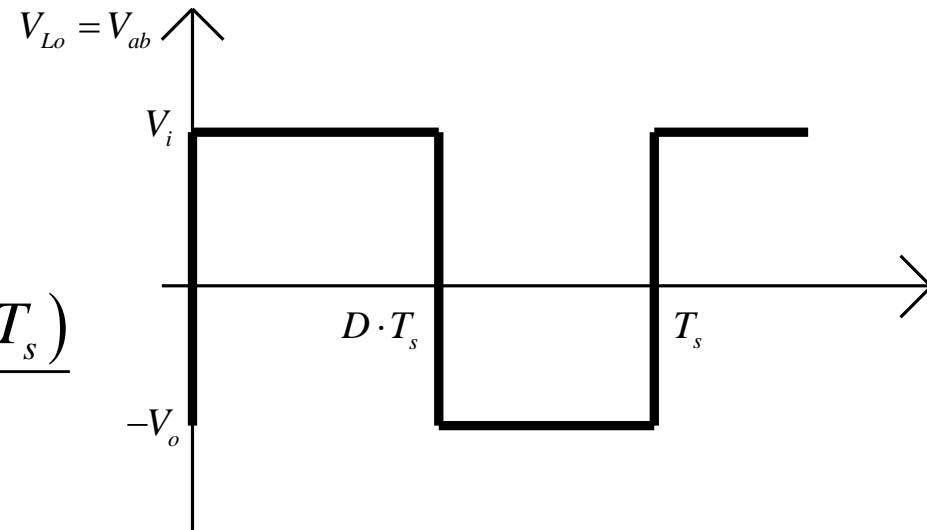

Converter Buck-Boost

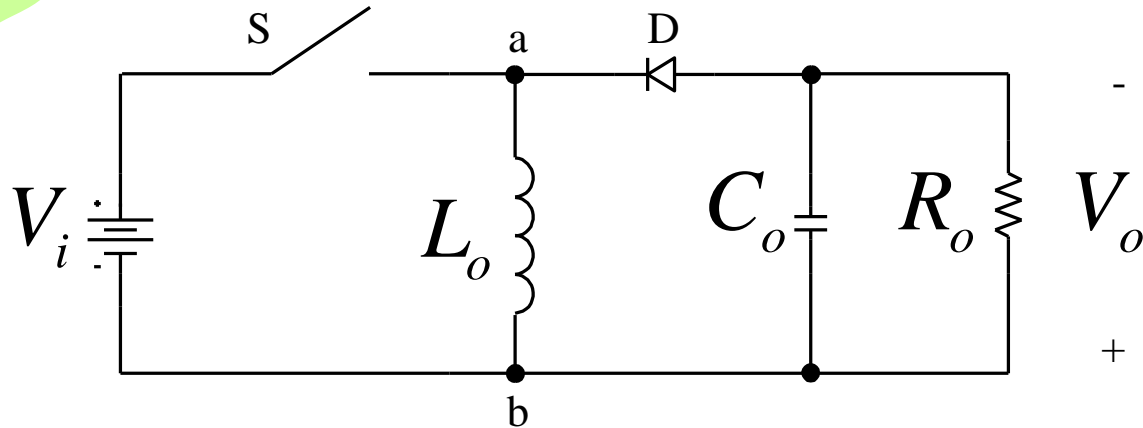

$$V_{ab} = \frac{1}{T_s} \int_0^{D \cdot T_s} V_i \cdot dt + \frac{1}{T_s} \int_{D \cdot T_s}^{T_s} (-V_o) \cdot dt$$

$$V_{ab} = V_i \cdot D - V_o \cdot (1 - D) = 0$$

$$V_i \cdot D = V_o \cdot (1 - D)$$

$$V_o = V_i \cdot \frac{D}{1 - D}$$

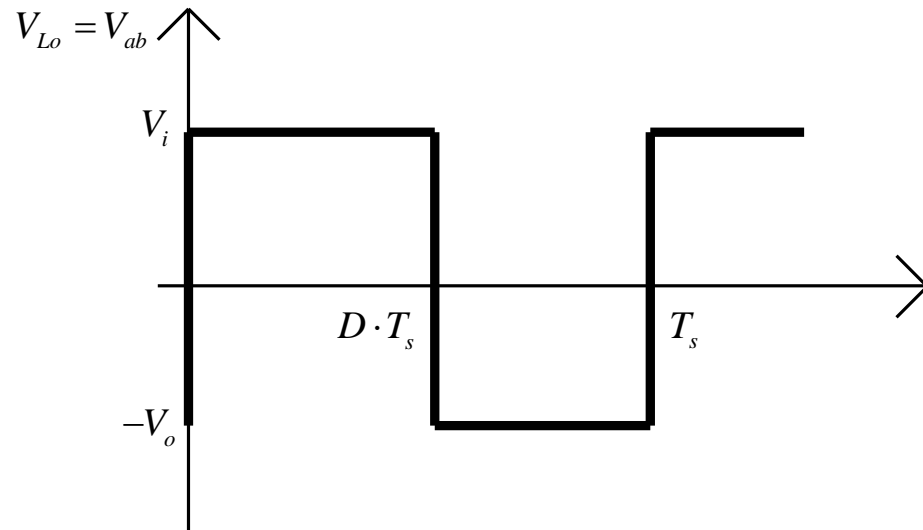

$$D = 1 + \frac{V_o}{V_i}$$

Conversor Buck-Boost

Ganho estático em função da razão cíclica:

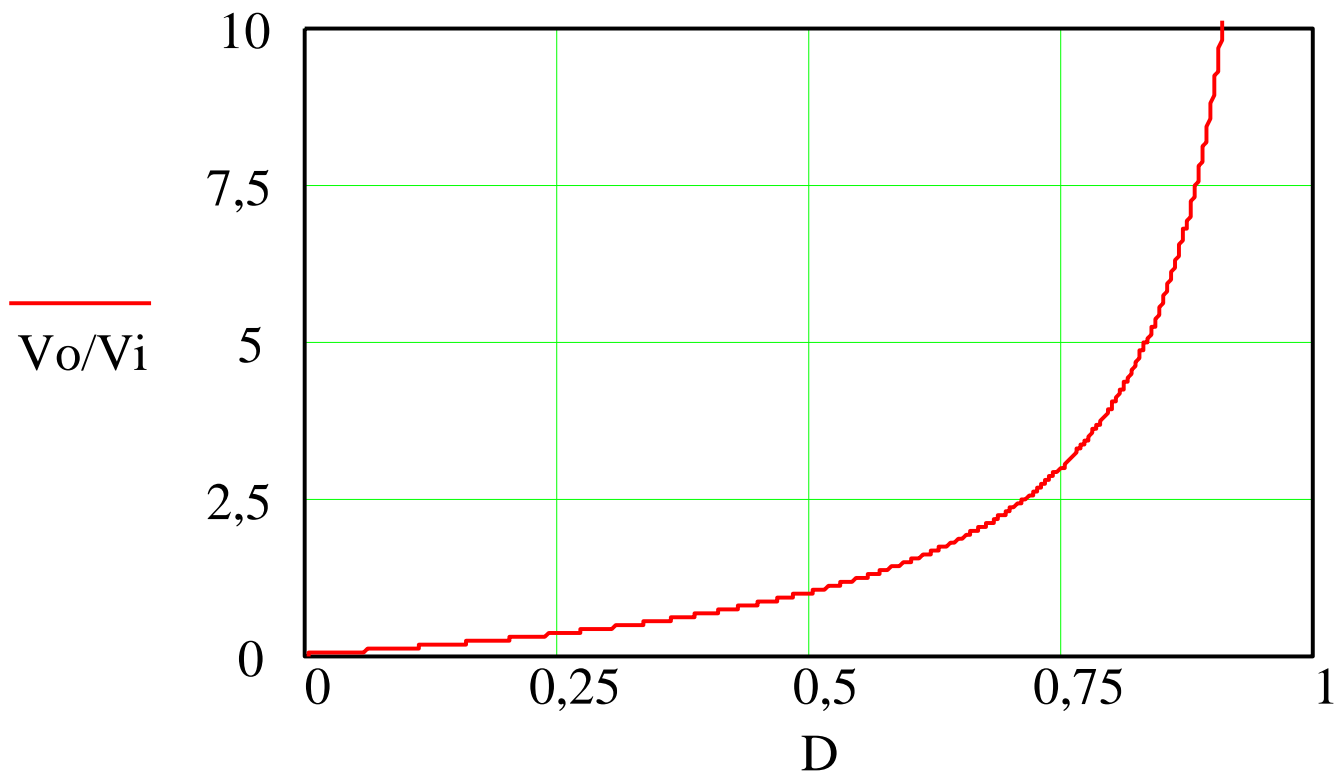

Outros conversores básicos - Cuk

1. Cuk

$$M(D) = -\frac{D}{1-D}$$

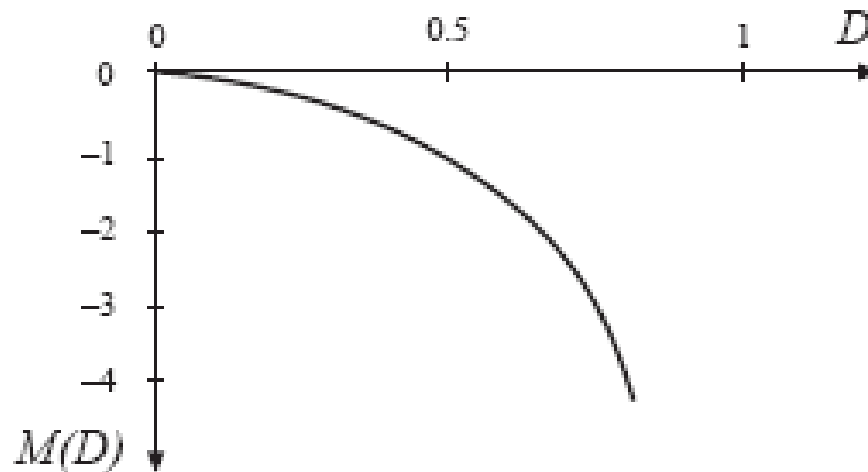
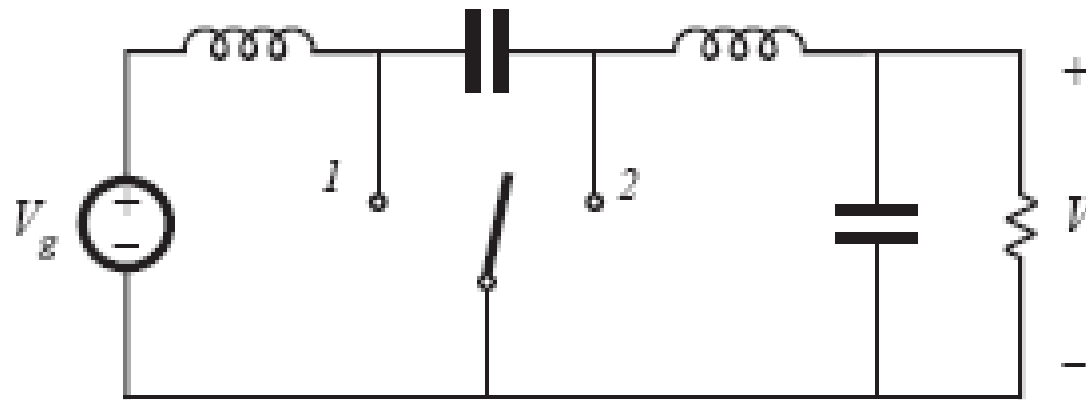

Outros conversores básicos - Sepic

2. SEPIC

$$M(D) = \frac{D}{1-D}$$

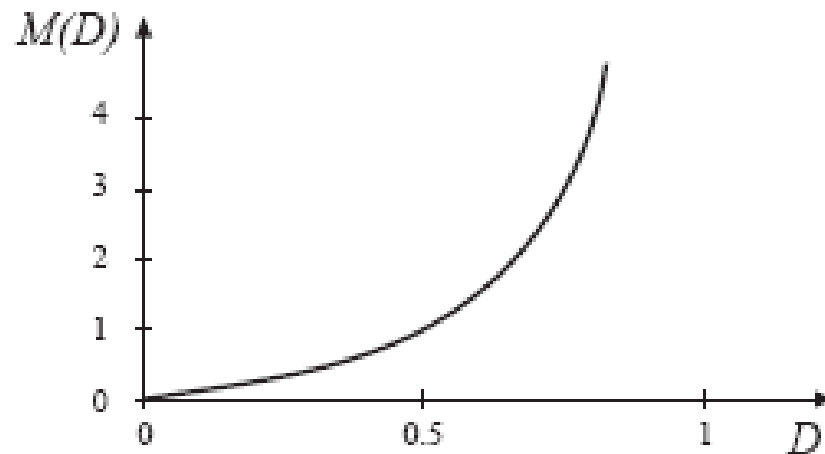
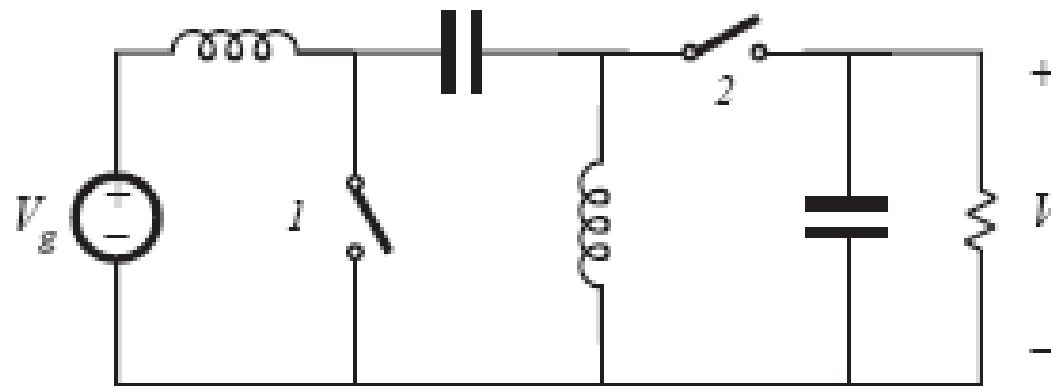

Outros conversores básicos - Zeta



Tabela comparativa dos conversores CC-CC

Conversor	Ganho estático	Característica
Buck	$\frac{V_o}{V_i} = D$	Abaixador
Boost	$\frac{V_o}{V_i} = \frac{1}{1-D}$	Elevador
Buck-Boost	$\frac{V_o}{V_i} = \frac{D}{1-D}$	Abaixador/Elevador
Cuk	$\frac{V_o}{V_i} = -\frac{D}{1-D}$	Abaixador/Elevador
Sepic	$\frac{V_o}{V_i} = \frac{D}{1-D}$	Abaixador/Elevador
Zeta	$\frac{V_o}{V_i} = \frac{D}{1-D}$	Abaixador/Elevador

Próxima aula

Capítulo 9: Choppers DC

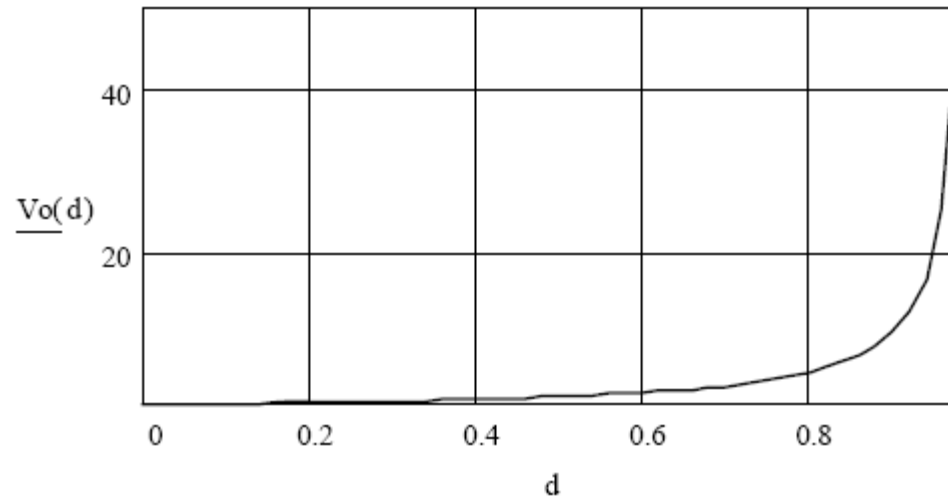
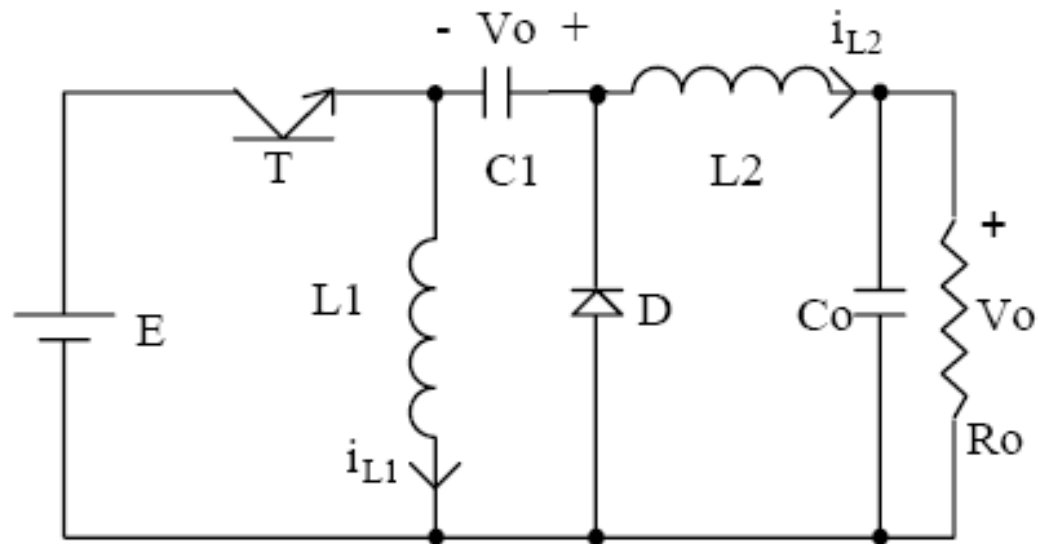
1. Laboratório de conversores CC-CC não-isolados.

