

Centro Federal de Educação Tecnológica de Santa Catarina
Departamento de Eletrônica
Eletrônica Básica

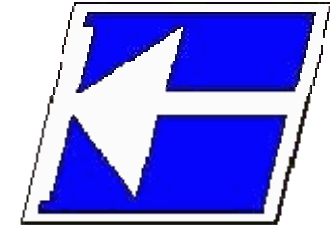

Alguns Detalhes Práticos de Componentes Eletrônicos

Prof. Clóvis Antônio Petry.

Florianópolis, outubro de 2007.

Nesta aula

Seqüência de conteúdos:

1. Resistores;
2. Termistores;
3. LDRs;
4. Varistores;
5. Capacitores;
6. LEDs;
7. Varicap;
8. Fotodiodos;
9. Fototransistores;
10. Optoacopladores;
11. Células solares.

Bibliografia

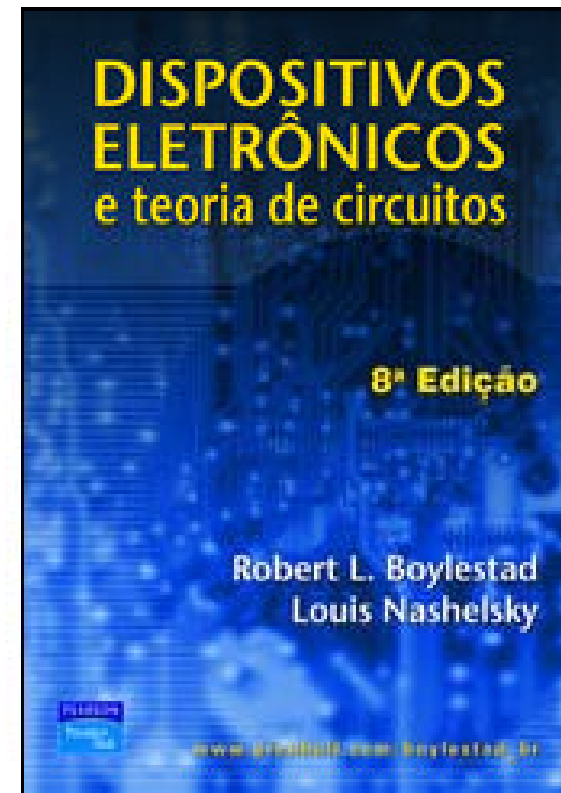
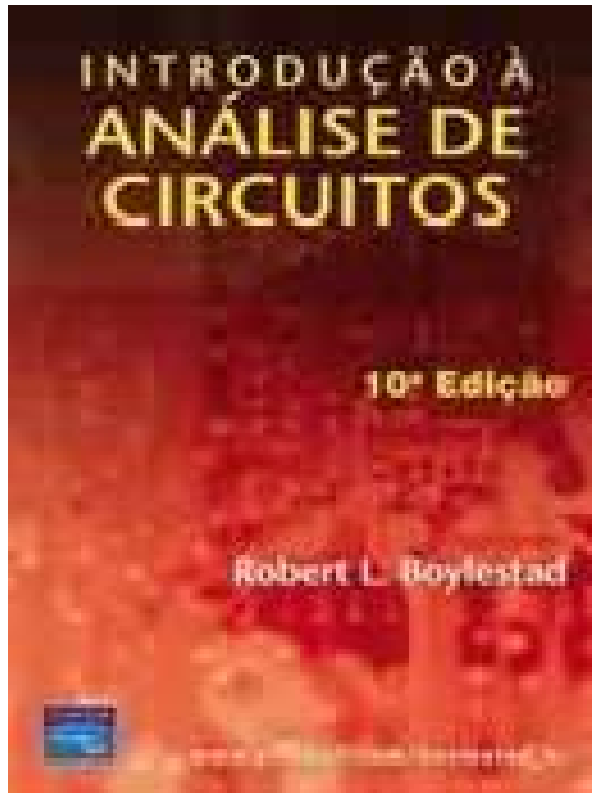

Resistores

Resistência depende de:

- Material;
- Comprimento;
- Área da seção reta;
- Temperatura.

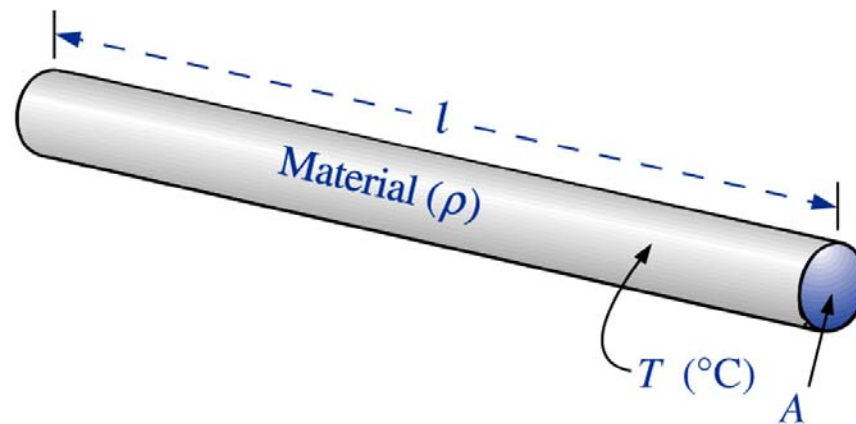
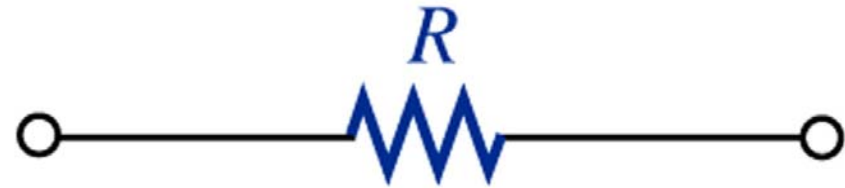

Resistores

Tipos de resistores:

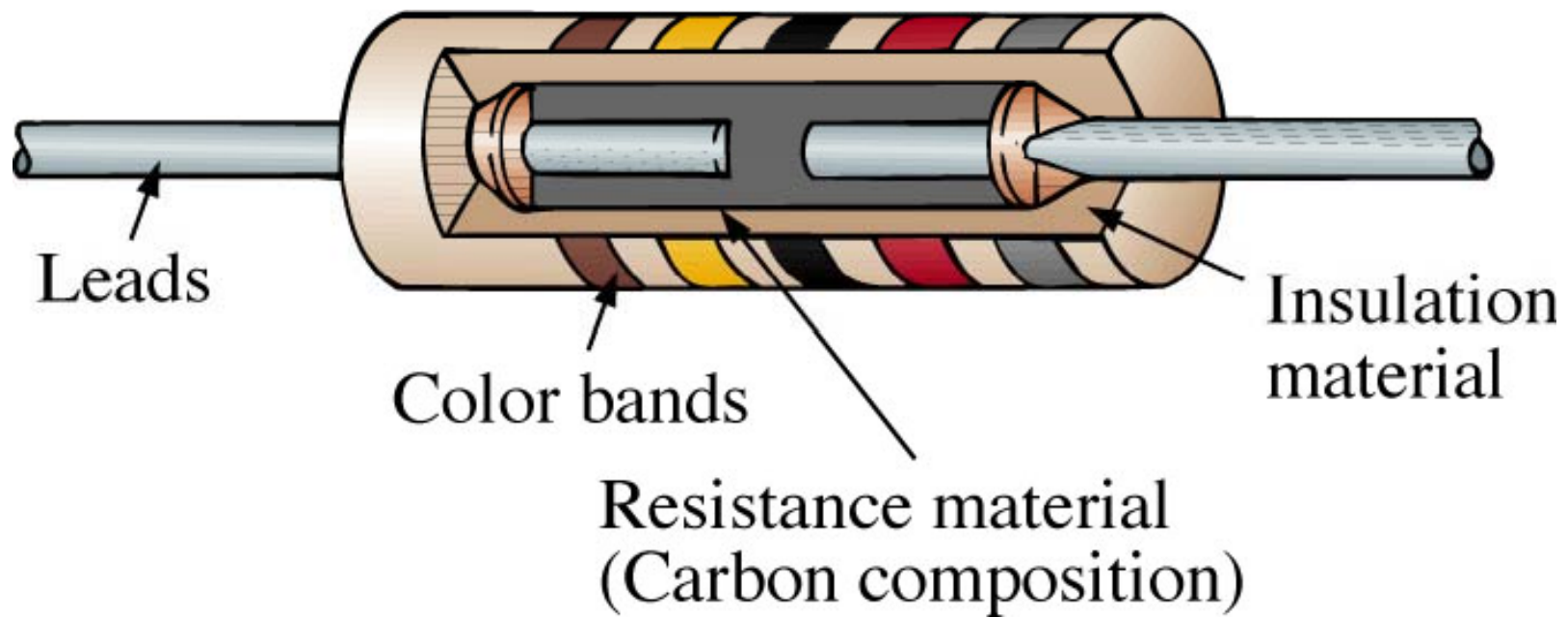

Resistor fixo de carbono.

Resistores

Tipos de resistores:

Resistores fixos de carbono com potências diferentes.



2 W



1 W



$\frac{1}{2}$ W



$\frac{1}{4}$ W

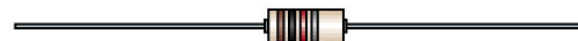

$\frac{1}{8}$ W

Resistores

Tipos de resistores:

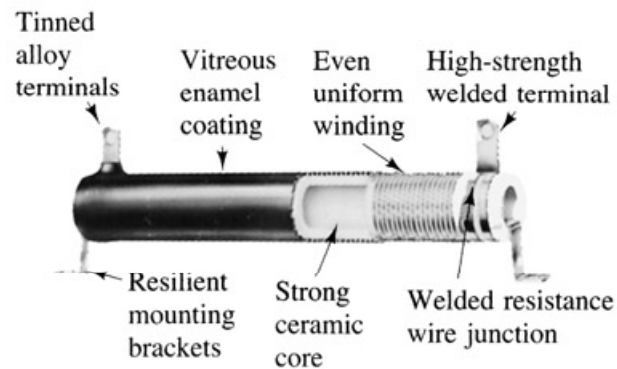

(a) Vitreous-enameled wire-wound resistor
App: All types of equipment

Resistores de
potência de fio.



(b) High-voltage cermet film resistors (on a high grade ceramic body).
App: For high-voltage applications up to 10 kV requiring high levels of stability.

Resistores para
altas tensões.



(c) Metal-film precision resistors
App: Where high stability, low temperature coefficient, and low noise level desired

Resistores de
precisão de filme
metálico.

Resistores

Tipos de resistores:



Resistores de potência.

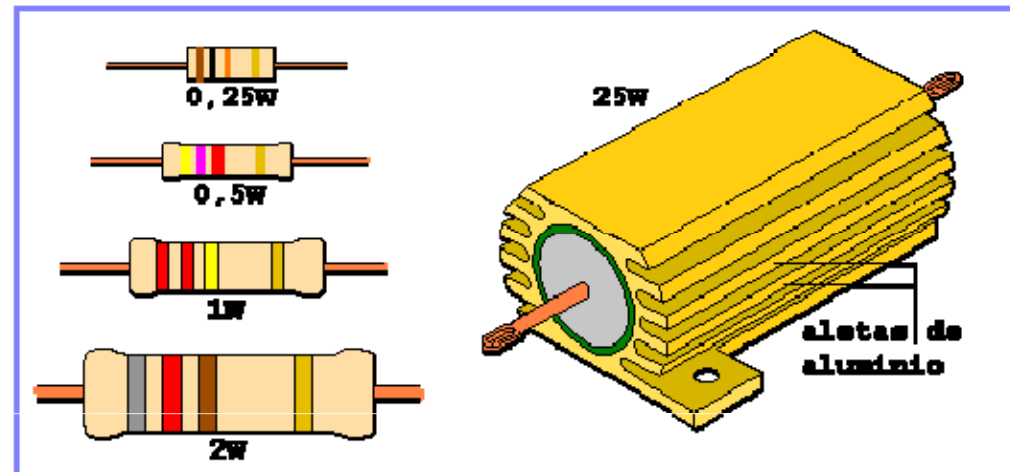

Resistores

Tipos de resistores:

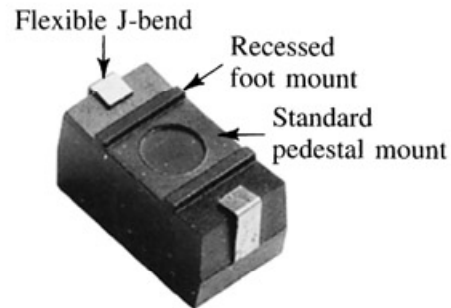

- (a) Surface mount power resistor ideal for printed circuit boards. Patented J-bends eliminate need for solder connections. (0.8 W to 3 W in wire-wound, film, or power film construction)

Resistores de
potência de fio.



- (b) Precision power wire-wound resistors with ratings as high as 2 W and tolerances as low as 0.05%. Temperature coefficients as low as 20 ppm/°C are also available.

Resistores de
precisão de fio.

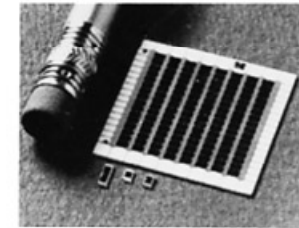

- (c) Thick-film chip resistors for design flexibility with hybrid circuitry. Pre-tinned, gold or silver electrodes available. Operating temperature range -55°C to +150°C.

Resistores de
filme em chip.

Resistores

Tipos de resistores:

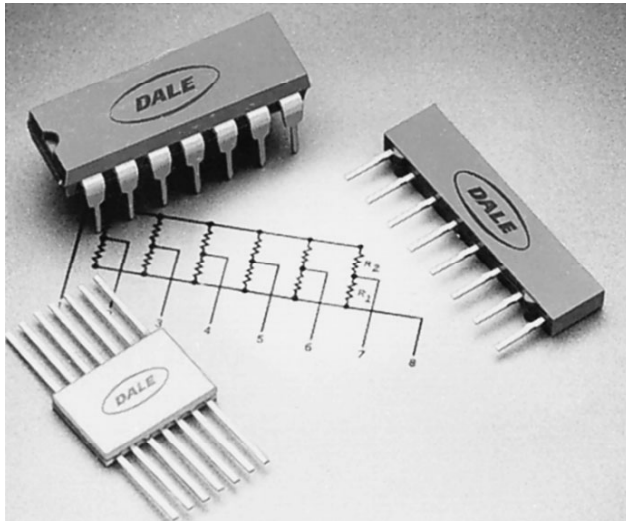

Resistores integrados e smd.

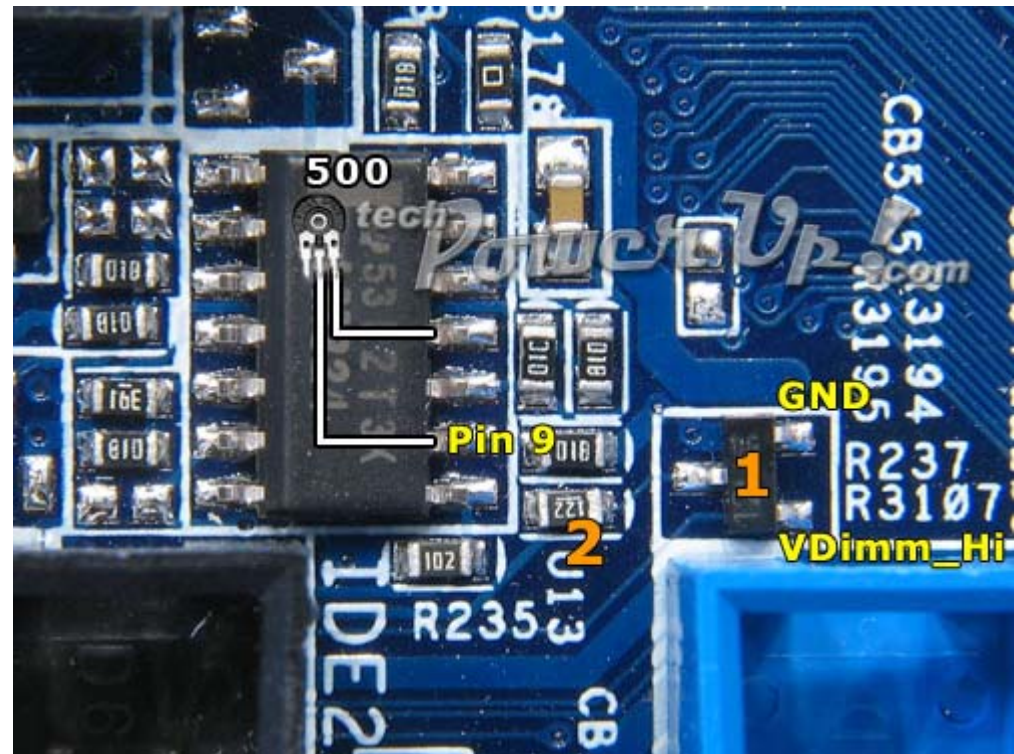

Resistores

Tipos de resistores:

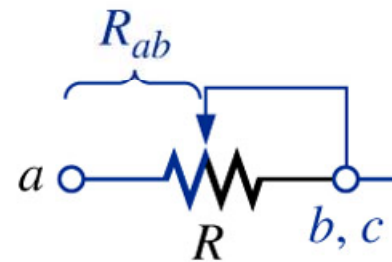
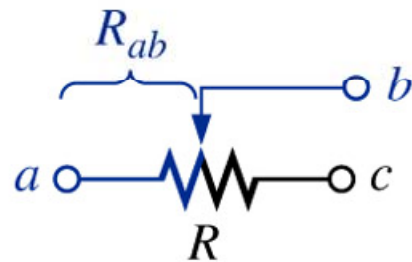
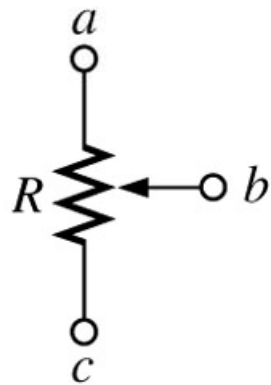

Resistores
variáveis e
ajustáveis.



Trimpots e
potenciômetros.

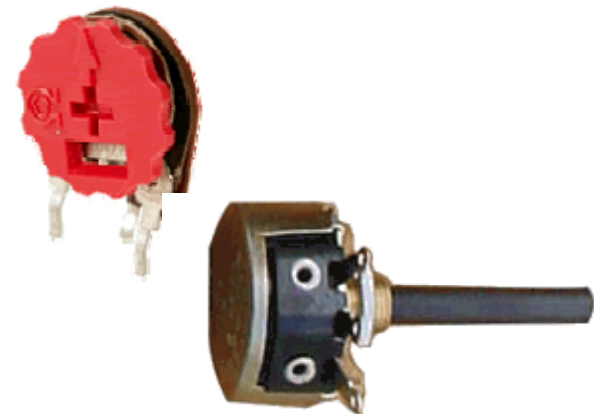

Resistores

Tipos de resistores:

Resistores variáveis e ajustáveis.

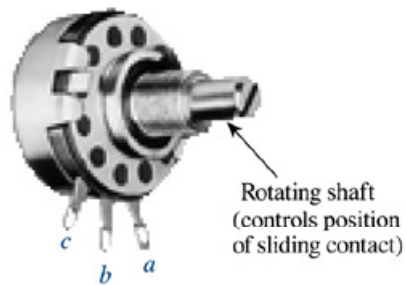

(a) External view

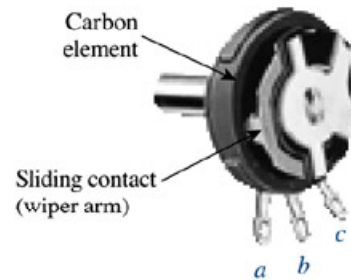

(b) Internal view

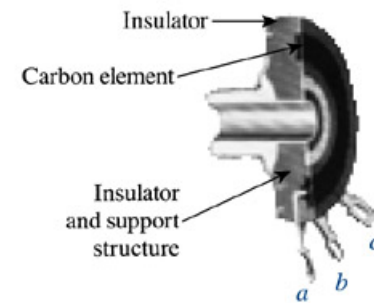

(c) Carbon element

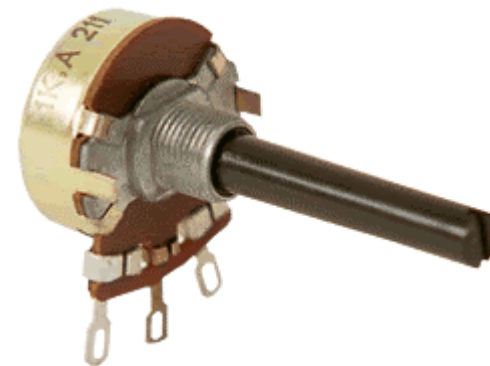
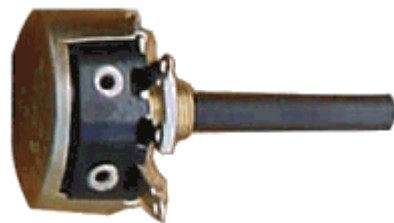

Resistores

Tipos de resistores:

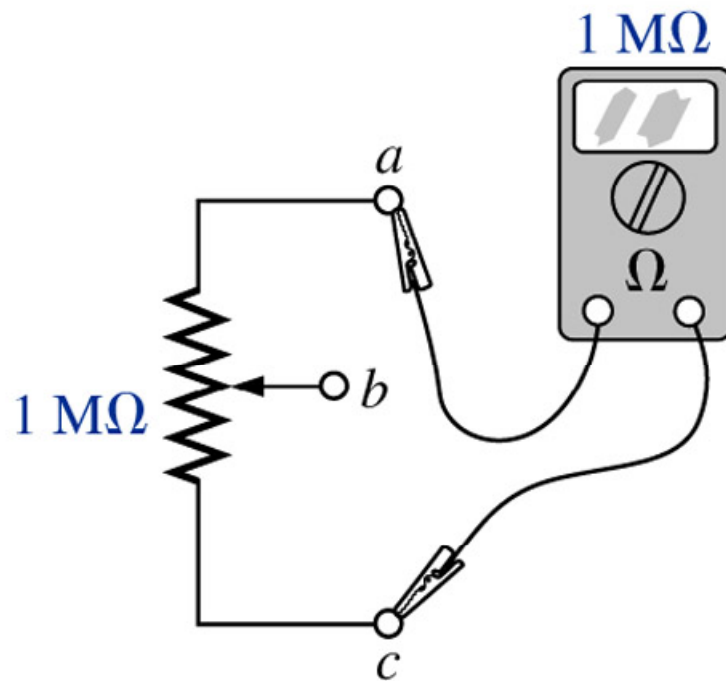

(a)

Resistores variáveis e ajustáveis.

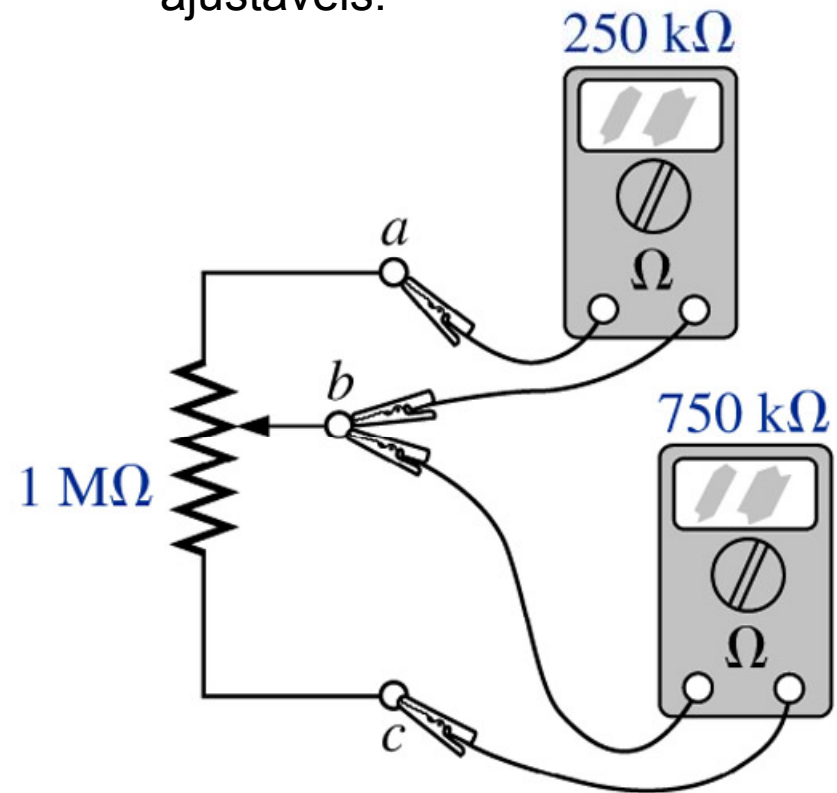

(b)

Resistores

Tipos de resistores:

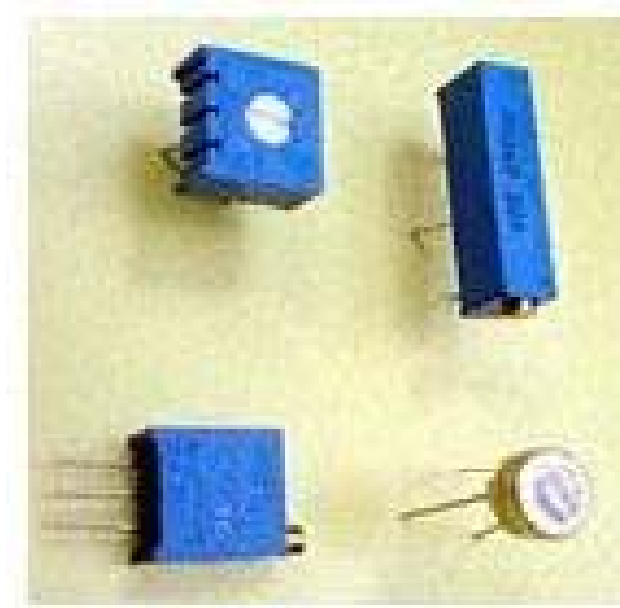
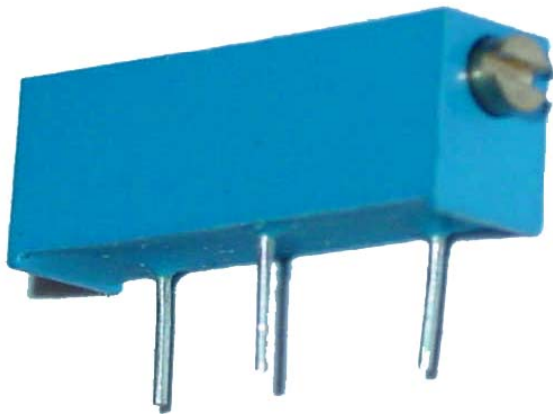

Resistores
variáveis e
ajustáveis.

Resistores

Tipos de resistores:

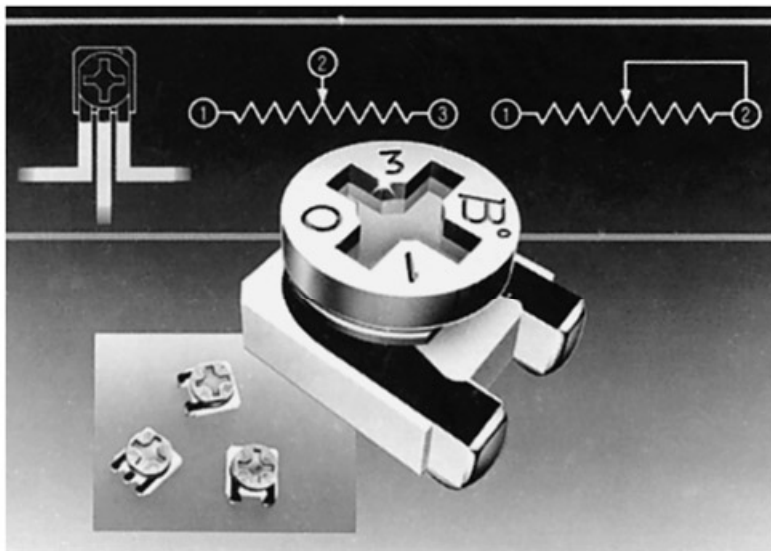

(a)

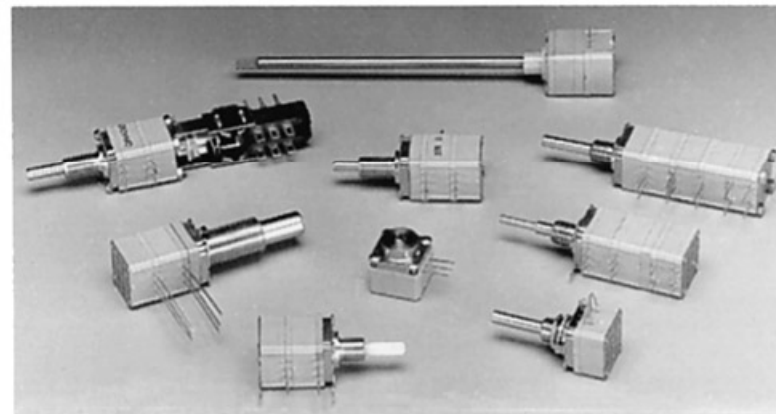

(b)

Potenciômetros
de precisão ou
multivoltas.

Termistores

Termistor:

- Resistor cuja resistência é sensível à variação da temperatura.

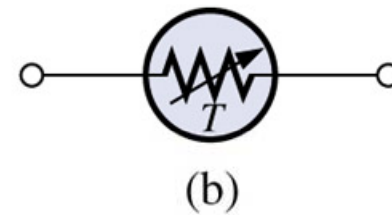
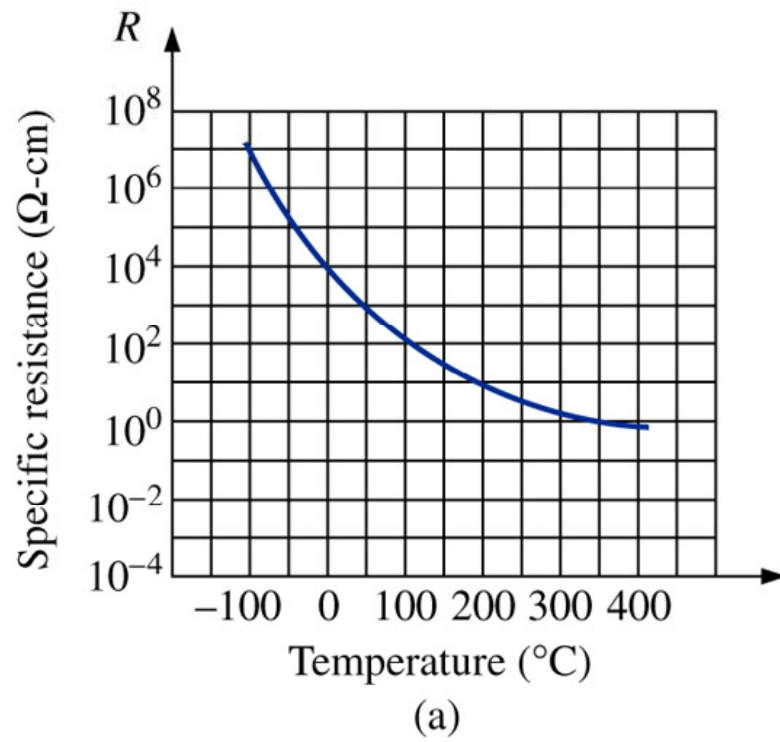

Termistores

Termistor NTC:

- Coeficiente negativo de temperatura;
- Resistência diminui com o aumento da temperatura.

Termistor PTC:

- Coeficiente positivo de temperatura;
- Resistência aumenta com o aumento da temperatura.

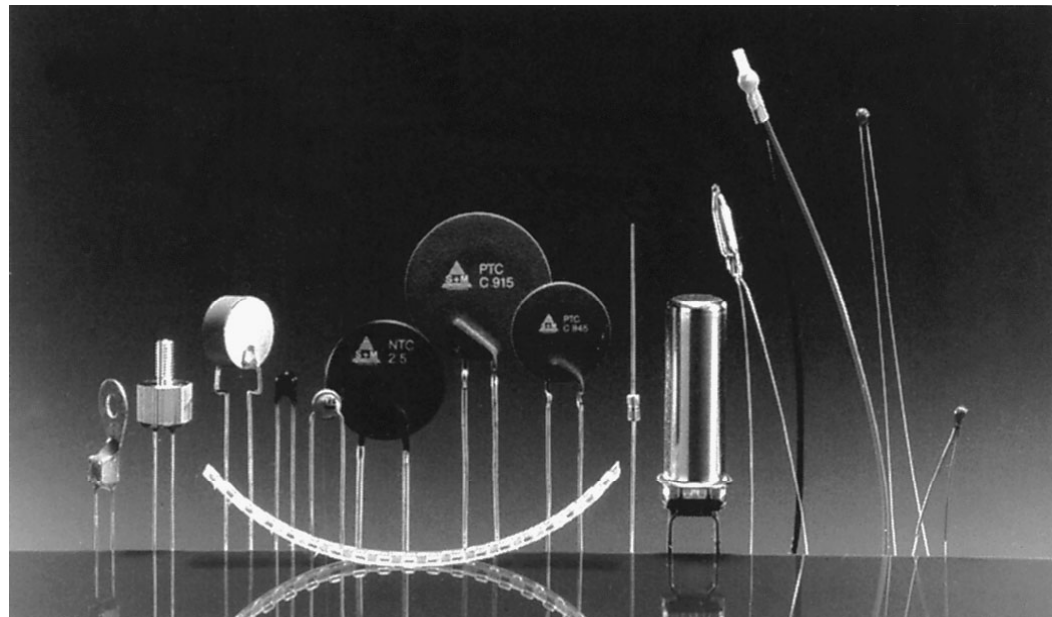

Célula fotocondutora ou LDR

LDR (Light dependent resistor) ou célula fotocondutora:

- A resistência é determinada pela intensidade da luz incidente em sua superfície.

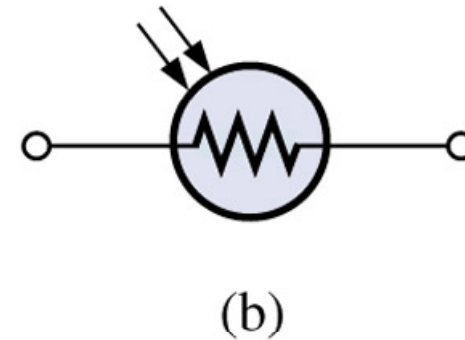
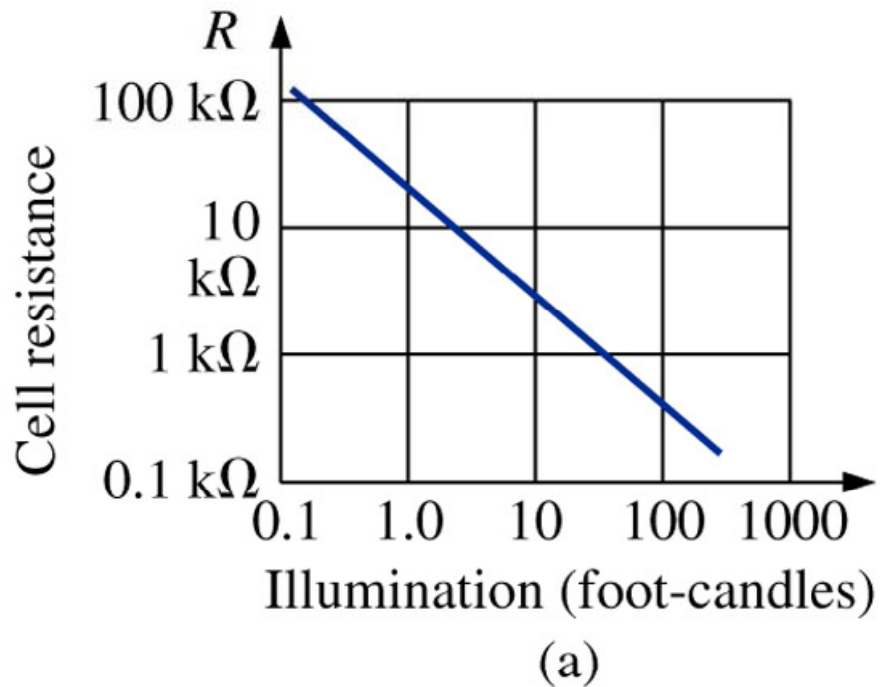

Célula fotocondutora ou LDR

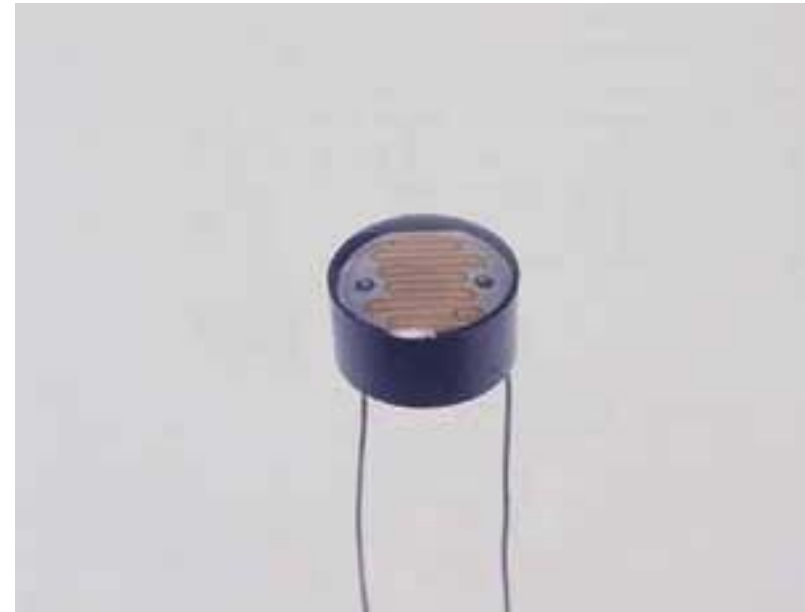
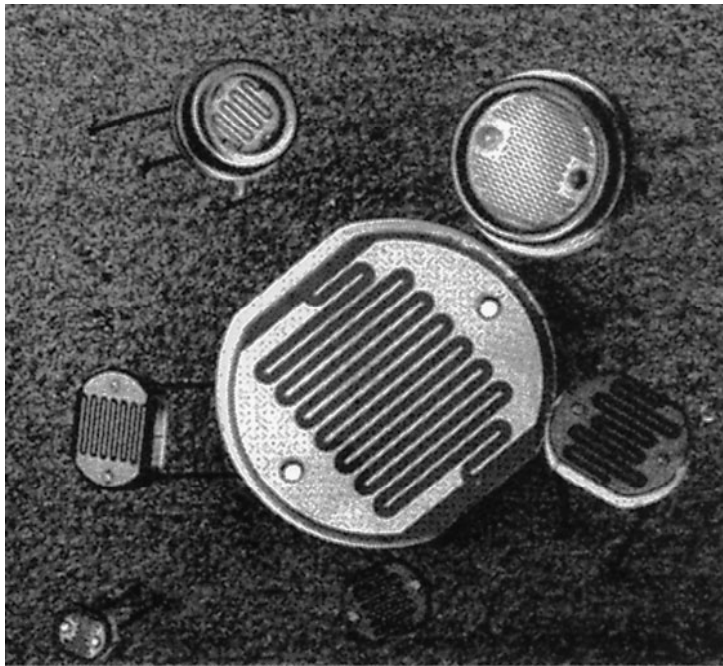

Varistores

Varistores:

- São resistores não-lineares, cuja resistência depende da tensão aplicada, usados para suprimir transientes de alta tensão.

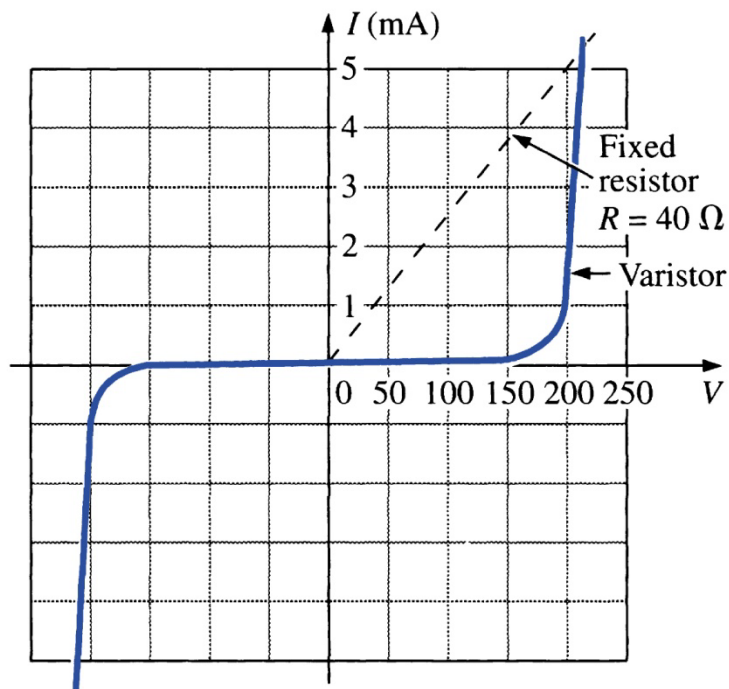

(a)

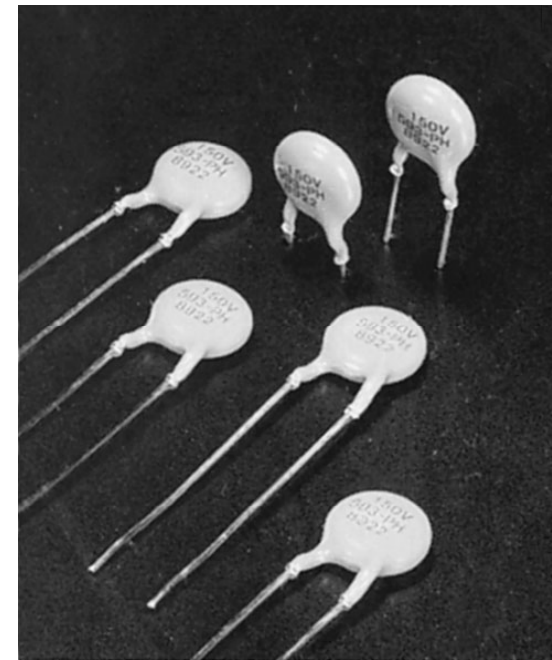

(b)

Resistores e similares

Testando resistores e similares:

Usando multímetro (Ω):

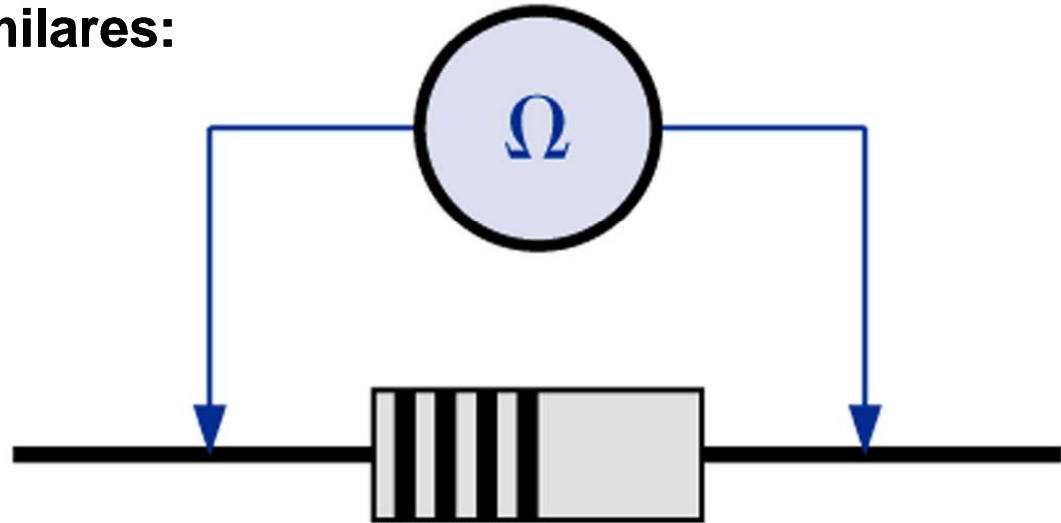

Aplicando a Lei de Ohm:

$$R = \frac{V}{I}$$

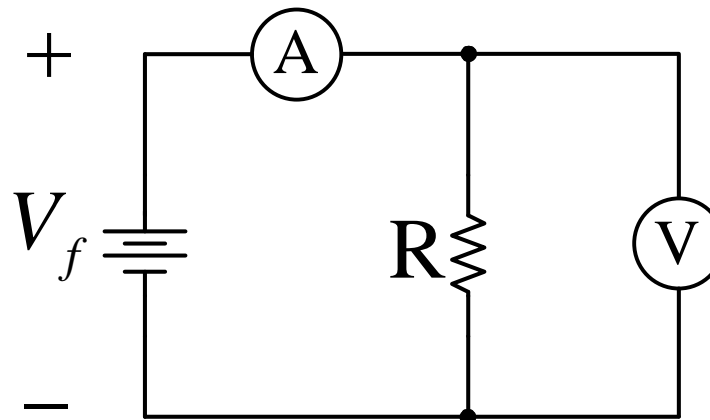

Capacitores

Capacitância depende de:

- Dielétrico (permissividade);
- Área das placas;
- Distância entre as placas.

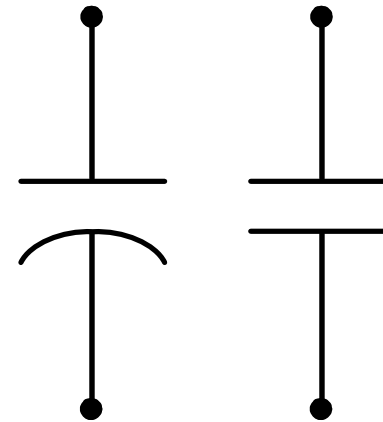
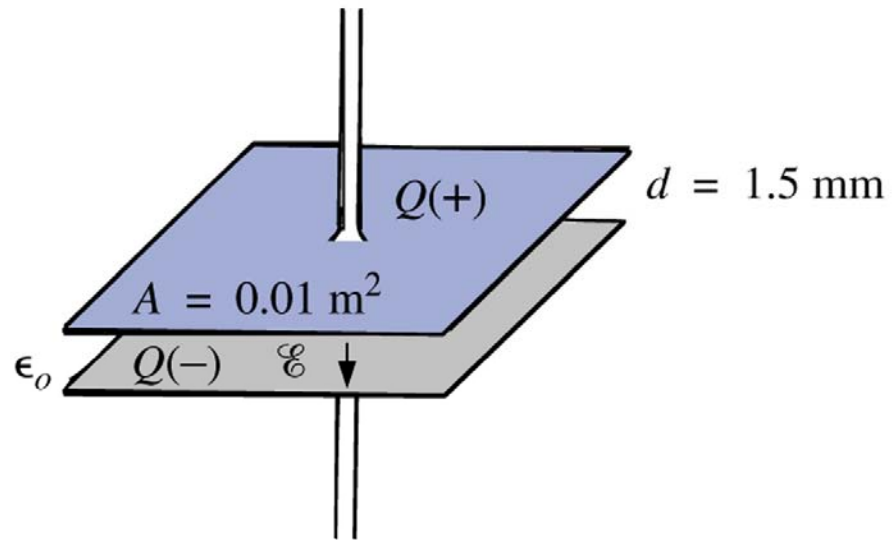

Capacitores

Tipos de capacitores:

Capacitores fixos de mica.

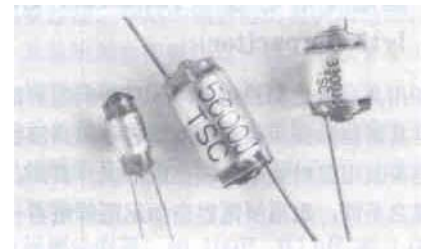
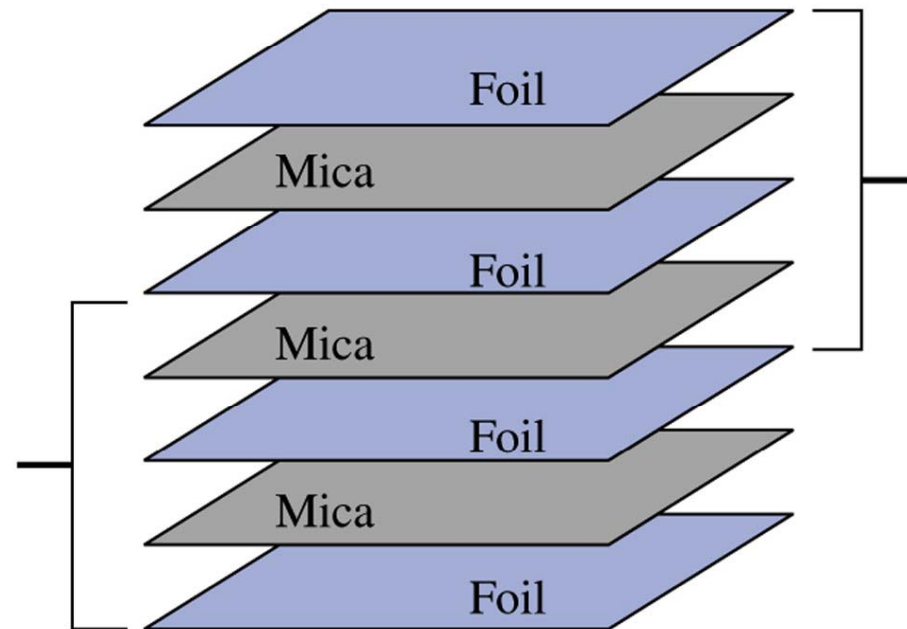

Capacitores

Tipos de capacitores:

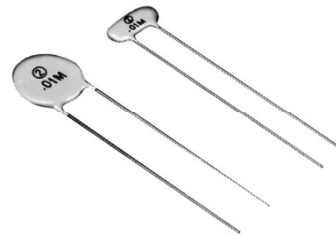

Capacitores de disco de cerâmica.

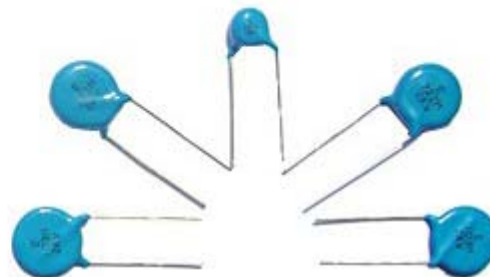
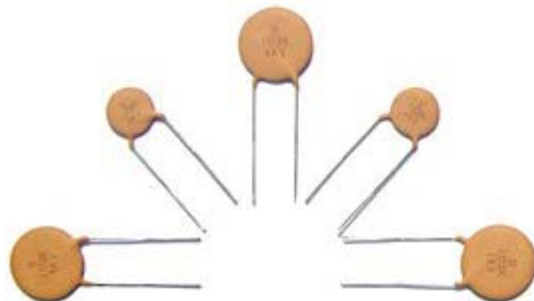
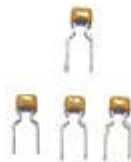
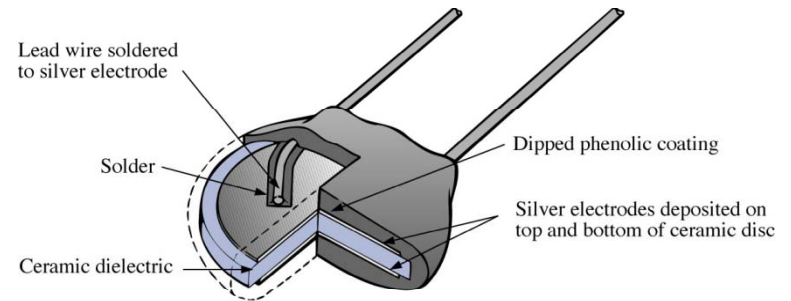

Capacitores

Tipos de capacitores:



(a)

Capacitores integrados.

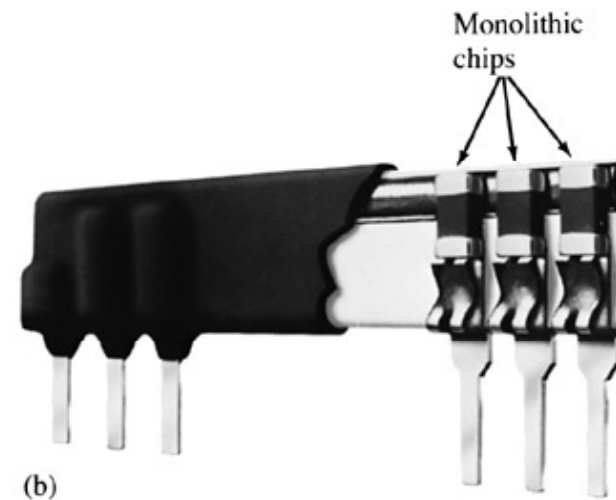

(b)

Capacitores

Tipos de capacitores:

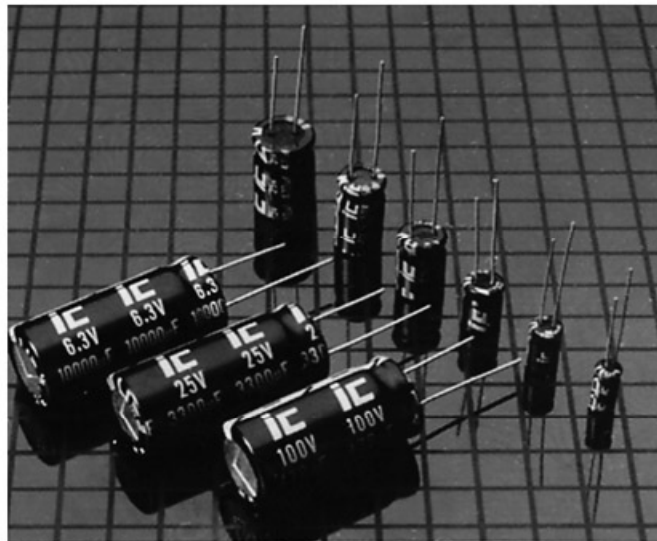

(a)

Capacitores eletrolíticos.

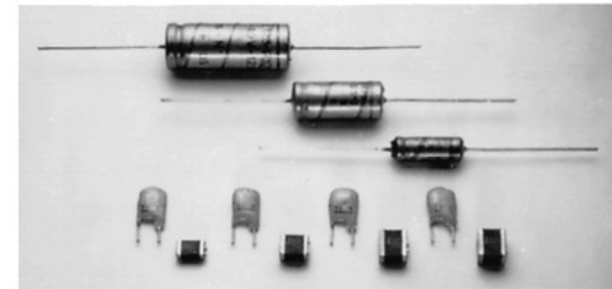

(b)



Capacitores

Tipos de capacitores:

Capacitores de tântalo.

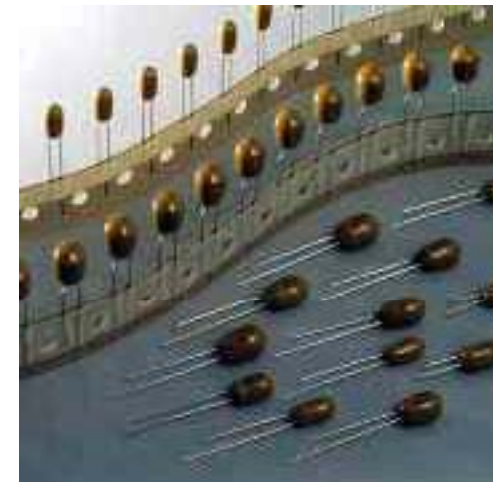
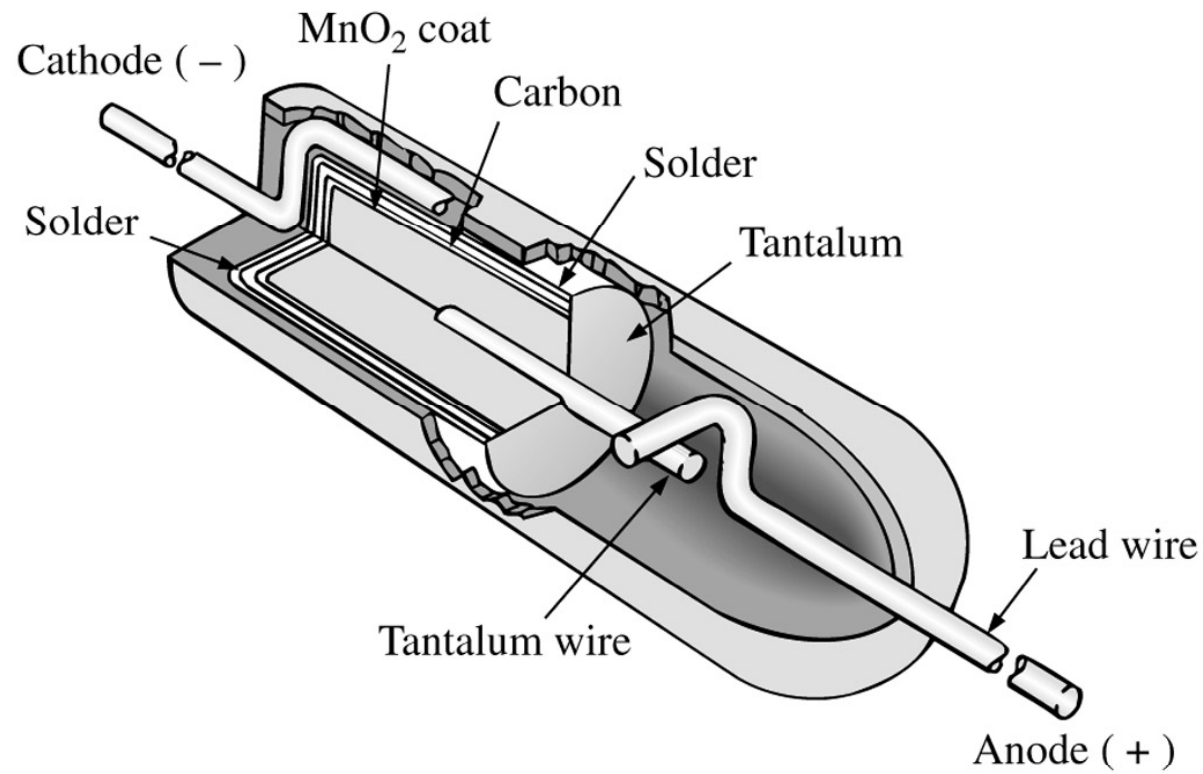

Capacitores

Tipos de capacitores:

Capacitores de filme de poliéster.

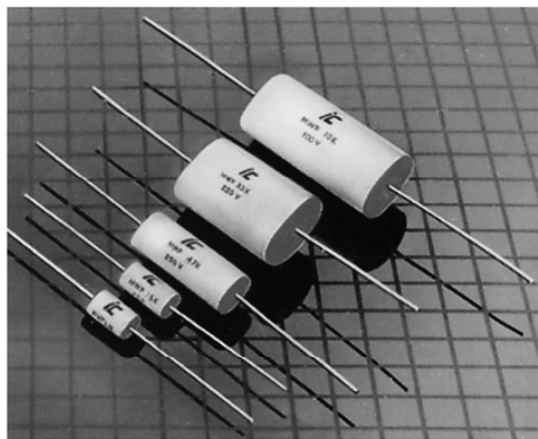
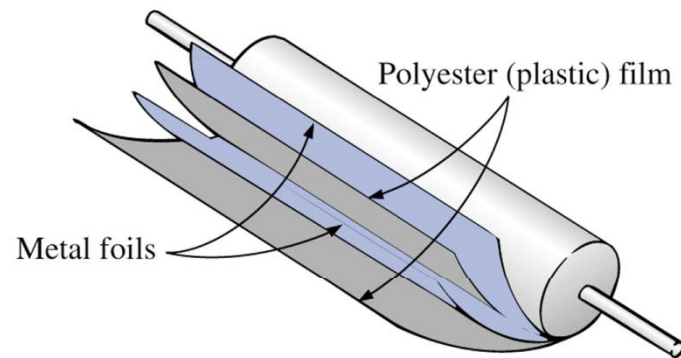

(a)

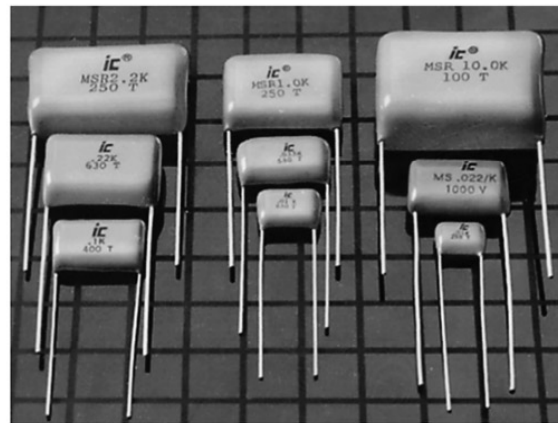

(b)

Capacitores

Tipos de capacitores:

Capacitores variáveis e ajustáveis.

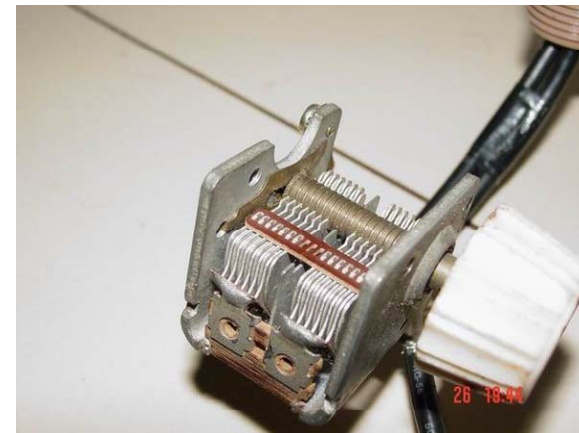
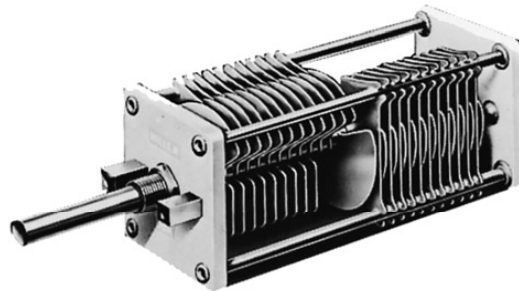

Capacitores

Tipos de capacitores:

Super capacitores



Small capacitance	3F, 2.3V – 300F, 2.3V	back-up power, on-board UPS, etc.
Medium capacitance	300F, 2.3V – 5000F, 2.7V	peak power, UPS, etc.
Large capacitance	5000F, 2.7V – 80.000F, 1.8 V	peak power, low maintenance energy storage, etc.
Supercapacitor modules	5V- 700V, capacitance on request.	Higher voltage applications



Capacitores

Tipos de capacitores, resumen:

Type: Miniature Axial Electrolytic
Typical Values: 0.1 μF to 15,000 μF
Typical Voltage Range: 5 V to 450 V
Capacitor tolerance: $\pm 20\%$
Applications: Polarized, used in DC power supplies, bypass filters, DC blocking.

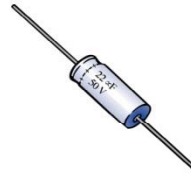

Type: Miniature Radial Electrolyte
Typical Values: 0.1 μF to 15,000 μF
Typical Voltage Range: 5 V to 450 V
Capacitor tolerance: $\pm 20\%$
Applications: Polarized, used in DC power supplies, bypass filters, DC blocking.



Type: Ceramic Disc
Typical Values: 10 pF to 0.047 μF
Typical Voltage Range: 100 V to 6 kV
Capacitor tolerance: $\pm 5\%$, $\pm 10\%$
Applications: Non-polarized, NPO type, stable for a wide range of temperatures. Used in oscillators, noise filters, circuit coupling, tank circuits.



Type: Dipped Tantalum (solid and wet)
Typical Values: 0.047 μF to 470 μF
Typical Voltage Range: 6.3 V to 50 V
Capacitor tolerance: $\pm 10\%$, $\pm 20\%$
Applications: Polarized, low leakage current, used in power supplies, high frequency noise filters, bypass filter.

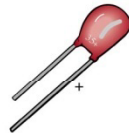

Type: Surface Mount Type (SMT)
Typical Values: 10 pF to 10 μF
Typical Voltage Range: 6.3 V to 16 V
Capacitor tolerance: $\pm 10\%$
Applications: Polarized and non-polarized, used in all types of circuits, requires a minimum amount of PC board real estate.

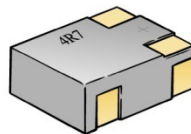

Type: Silver Mica
Typical Value: 10 pF to 0.001 μF
Typical Voltage Range: 50 V to 500 V
Capacitor tolerance: $\pm 5\%$
Applications: Non-polarized, used in oscillators, in circuits that require a stable component over a range of temperatures and voltages.



Type: Mylar Paper
Typical Value: 0.001 μF to 0.68 μF
Typical Voltage Range: 50 V to 600 V
Capacitor tolerance: $\pm 22\%$
Applications: Non-polarized, used in all types of circuits, moisture resistant.



Type: AC/DC Motor Run
Typical Value: 0.25 μF to 1200 μF
Typical Voltage Range: 240 V to 660 V
Capacitor tolerance: $\pm 10\%$
Applications: Non-polarized, used in motor run-start, high-intensity lighting supplies, AC noise filtering.



Type: Trimmer Variable
Typical Value: 1.5 pF to 600 pF
Typical Voltage Range: 5 V to 100 V
Capacitor tolerance: $\pm 10\%$
Applications: Non-polarized, used in oscillators, tuning circuits, AC filters.



Type: Tuning variable
Typical Value: 10 pF to 600 pF
Typical Voltage Range: 5 V to 100 V
Capacitor tolerance: $\pm 10\%$
Applications: Non-polarized, used in oscillators, radio tuning circuit.

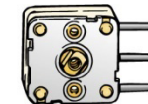

Capacitores

Tipos de capacitores:

Type: Miniature Axial Electrolytic

Typical Values: 0.1 μF to 15,000 μF

Typical Voltage Range: 5 V to 450 V

Capacitor tolerance: $\pm 20\%$

Applications: Polarized, used in DC power supplies, bypass filters, DC blocking.

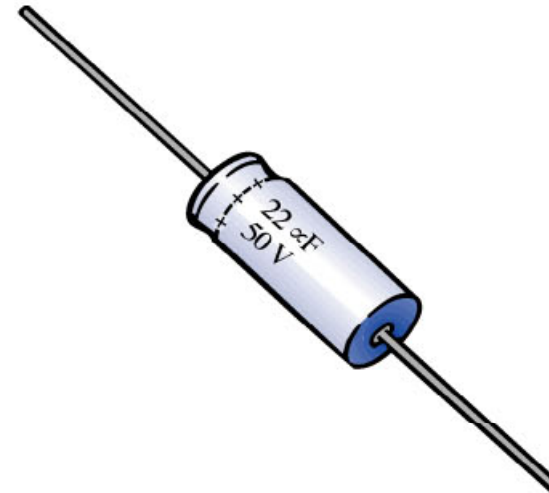

Capacitores

Tipos de capacitores:

Type: Miniature Radial Electrolyte

Typical Values: 0.1 μF to 15,000 μF

Typical Voltage Range: 5 V to 450 V

Capacitor tolerance: $\pm 20\%$

Applications: Polarized, used in DC power supplies, bypass filters, DC blocking.



Capacitores

Tipos de capacitores:

Type: Ceramic Disc

Typical Values: 10 pF to 0.047 μ F

Typical Voltage Range: 100 V to 6 kV

Capacitor tolerance: $\pm 5\%$, $\pm 10\%$

Applications: Non-polarized, NPO type, stable for a wide range of temperatures. Used in oscillators, noise filters, circuit coupling, tank circuits.

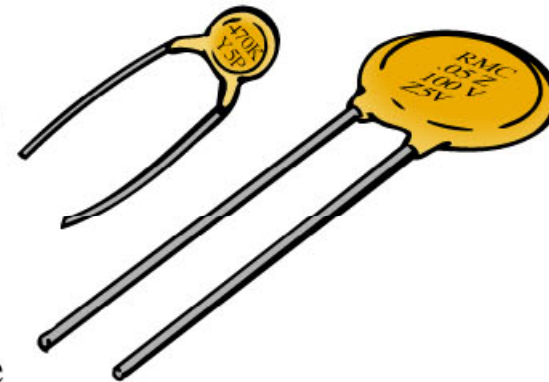

Capacitores

Tipos de capacitores:

Type: Dipped Tantalum (solid and wet)

Typical Values: 0.047 μ F to 470 μ F

Typical Voltage Range: 6.3 V to 50 V

Capacitor tolerance: $\pm 10\%$, $\pm 20\%$

Applications: Polarized, low leakage current, used in power supplies, high frequency noise filters, bypass filter.

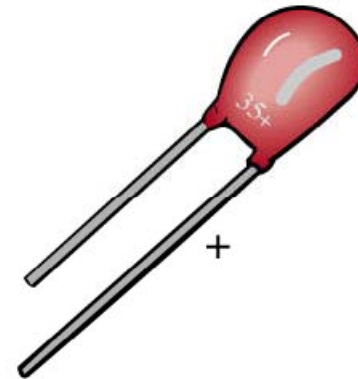

Capacitores

Tipos de capacitores:

Type: Surface Mount Type (SMT)

Typical Values: 10 pF to 10 μ F

Typical Voltage Range: 6.3 V to 16 V

Capacitor tolerance: $\pm 10\%$

Applications: Polarized and non-polarized, used in all types of circuits, requires a minimum amount of PC board real estate.

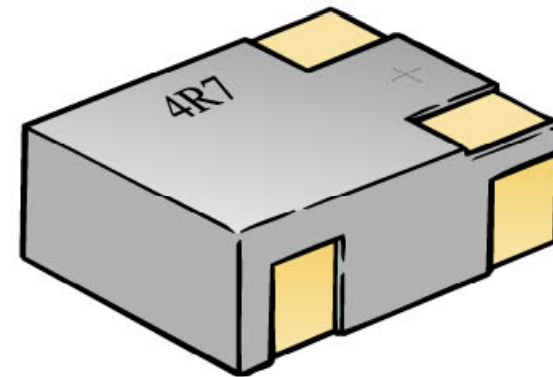

Capacitores

Tipos de capacitores:

Type: Silver Mica

Typical Value: 10 pF to 0.001 μ F

Typical Voltage Range: 50 V to 500 V

Capacitor tolerance: $\pm 5\%$

Applications: Non-polarized, used in oscillators, in circuits that require a stable component over a range of temperatures and voltages.

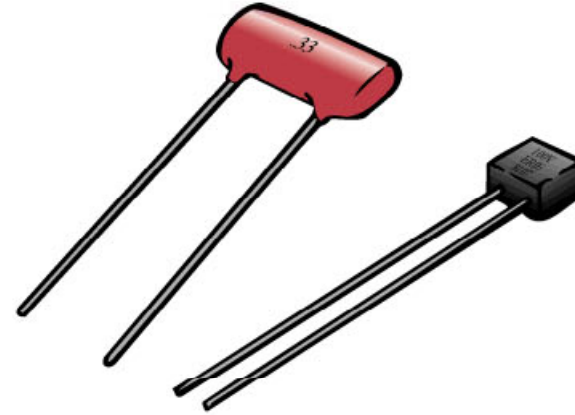

Capacitores

Tipos de capacitores:

Type: Mylar Paper

Typical Value: 0.001 μF to 0.68 μF

Typical Voltage Range: 50 V to 600 V

Capacitor tolerance: $\pm 22\%$

Applications: Non-polarized, used in all types of circuits, moisture resistant.

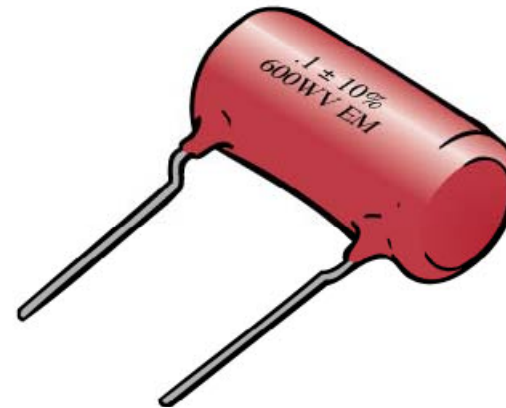

Capacitores

Tipos de capacitores:

Type: AC/DC Motor Run

Typical Value: 0.25 μ F to 1200 μ F

Typical Voltage Range: 240 V to 660 V

Capacitor tolerance: $\pm 10\%$

Applications: Non-polarized, used in motor run-start, high-intensity lighting supplies, AC noise filtering.



Capacitores

Tipos de capacitores:

Type: Trimmer Variable

Typical Value: 1.5 pF to 600 pF

Typical Voltage Range: 5 V to 100 V

Capacitor tolerance: $\pm 10\%$

Applications: Non-polarized, used in oscillators, tuning circuits, AC filters.



Capacitores

Tipos de capacitores:

Type: Tuning variable

Typical Value: 10 pF to 600 pF

Typical Voltage Range: 5 V to 100 V

Capacitor tolerance: $\pm 10\%$

Applications: Non-polarized, used in oscillators, radio tuning circuit.

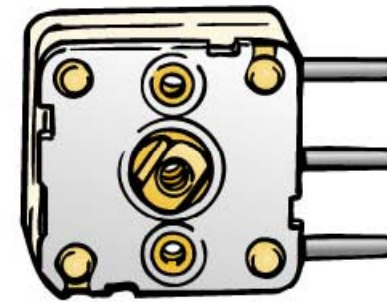

Capacitores

Testando capacitores:

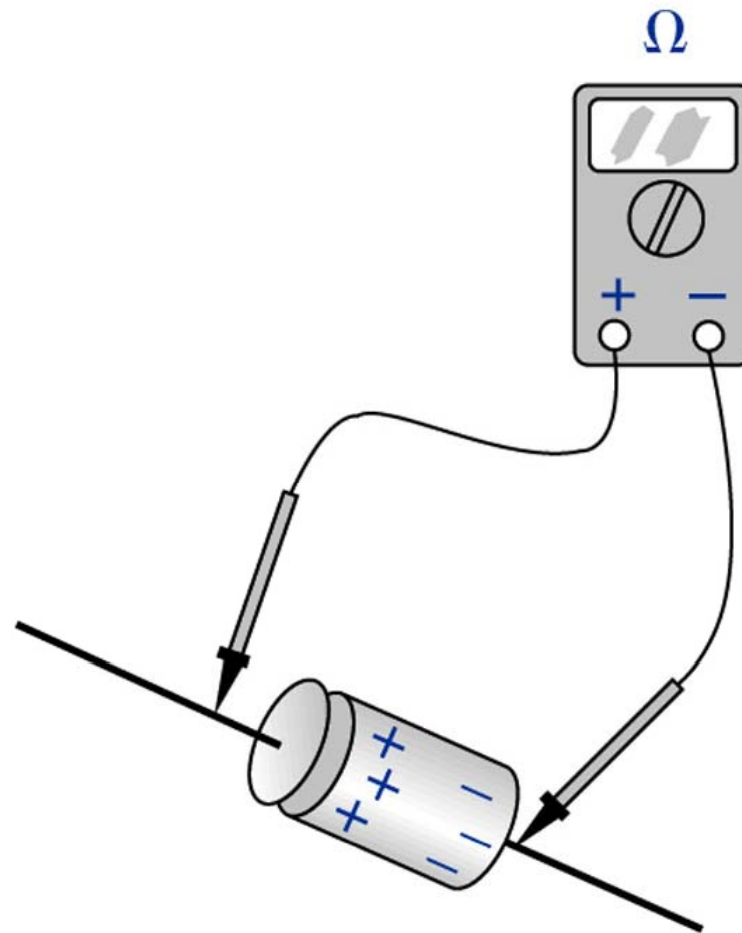

LED

Diodos emissores de luz (LEDs):

- Eletroluminescência – processo de emissão de luz pela aplicação de uma fonte elétrica de energia.

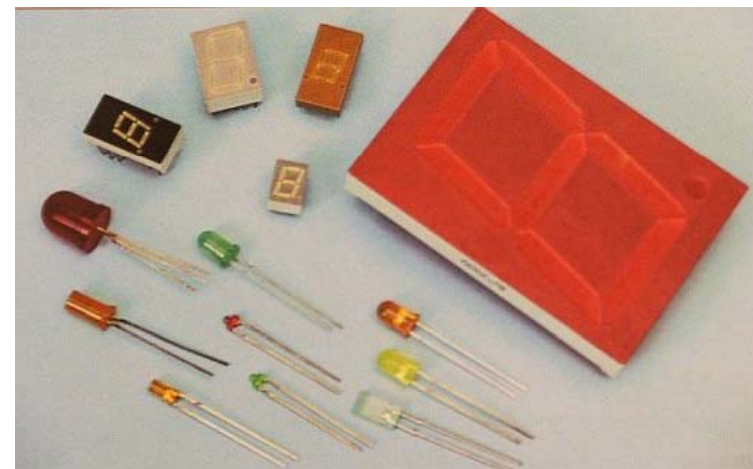
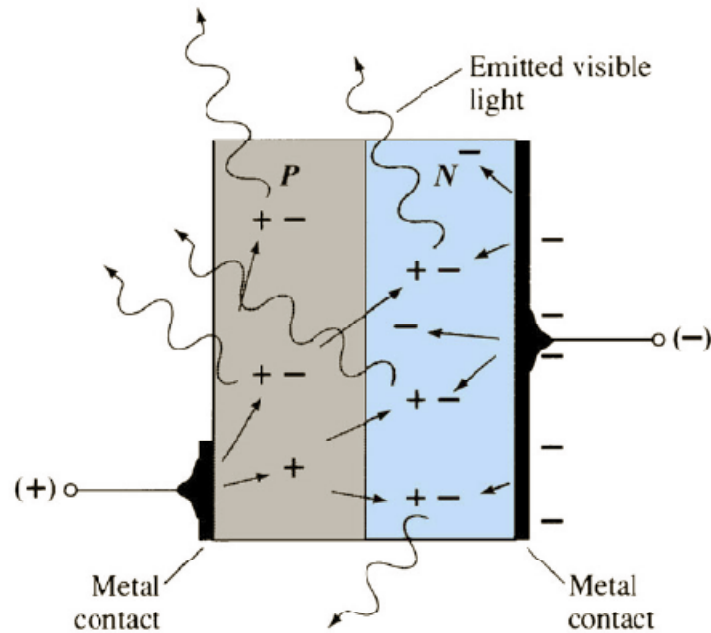

LED

Comprimentos de onda dos leds:

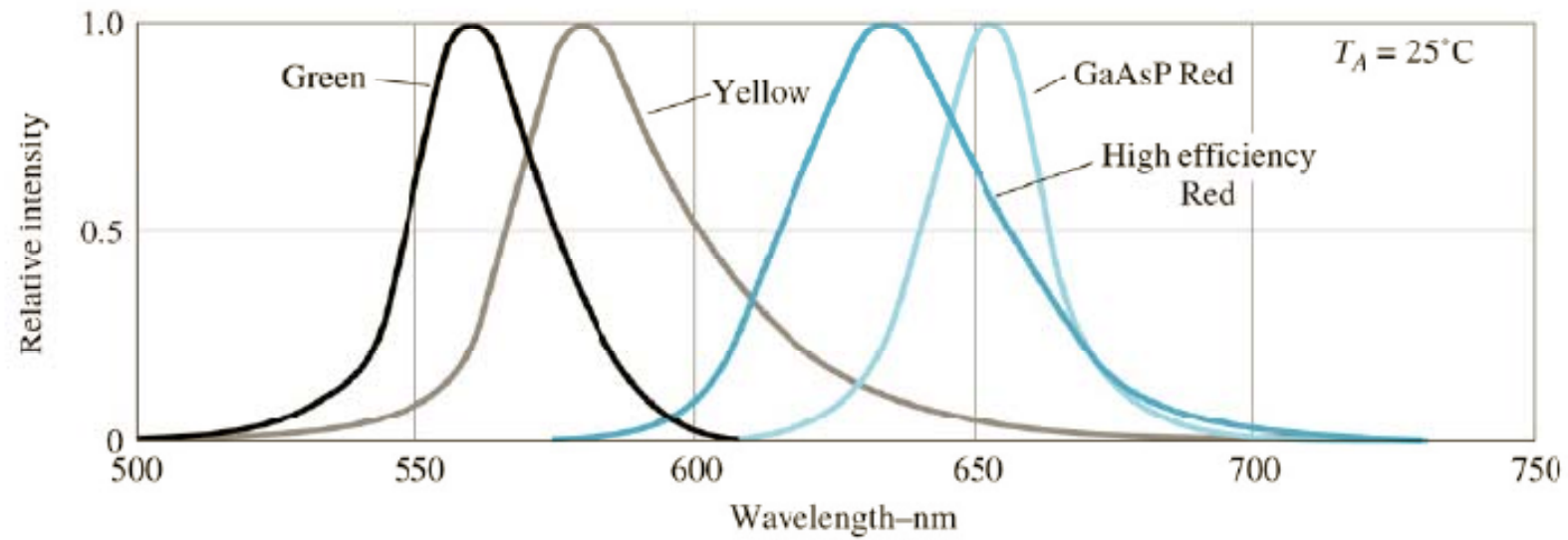

LED

Corrente direta versus tensão direta para leds miniatura:

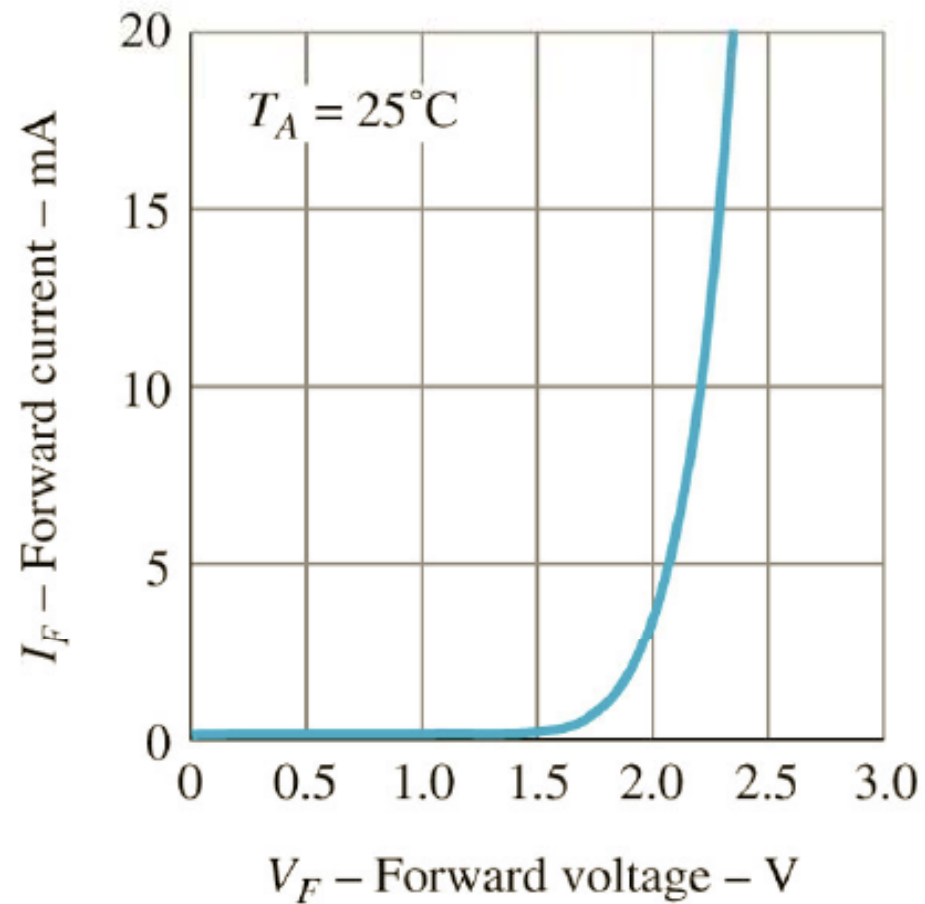

Diodos Varactor (Varicap)

Varicap:

- São diodos que variam sua capacitância com a tensão aplicada nos seus terminais.

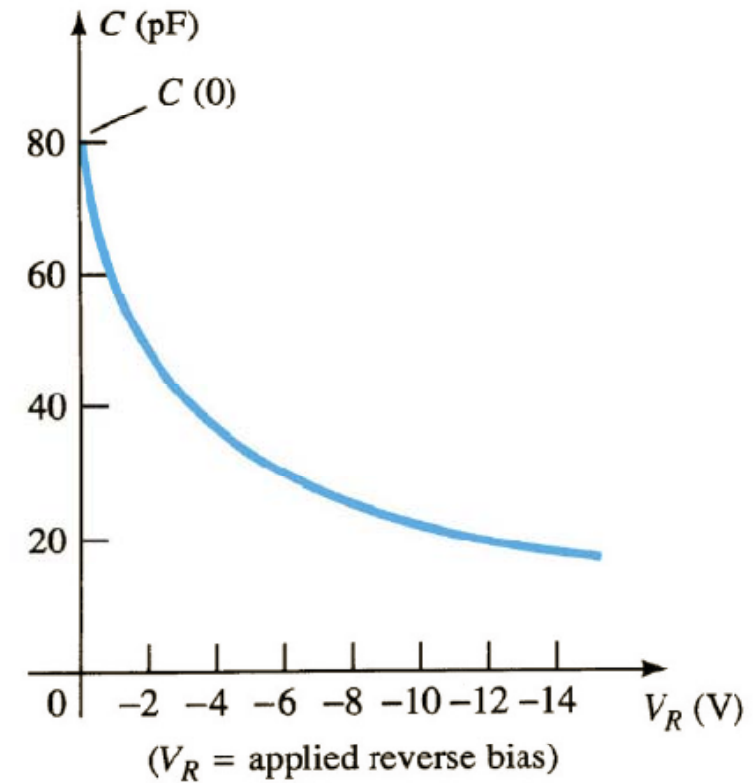
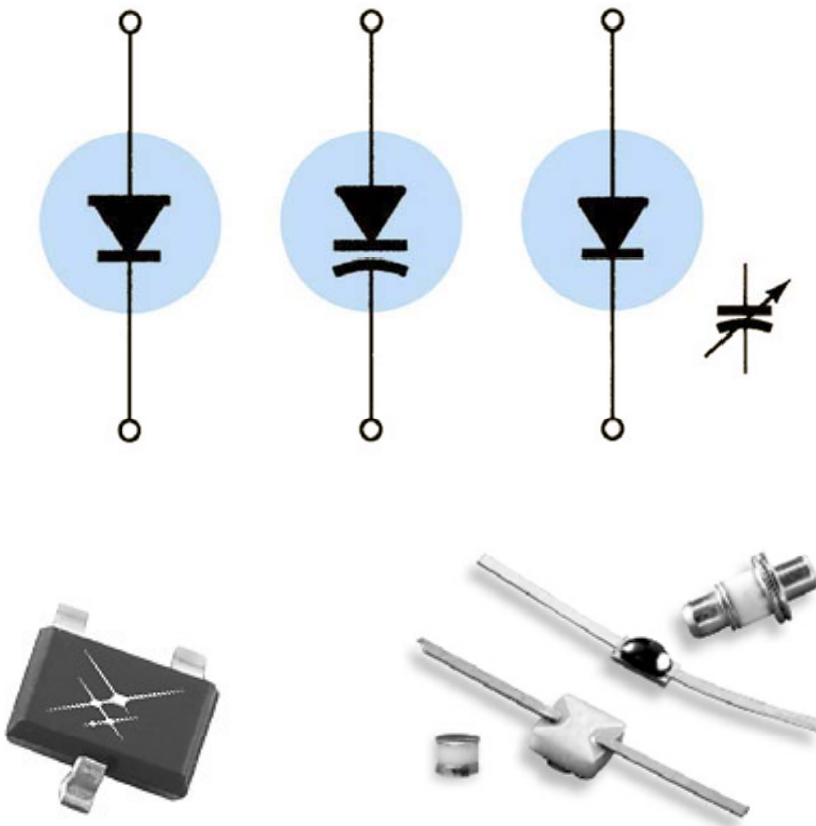

Fotodiodos

Fotodiodos:

- São diodos que operam na região reversa e são sensíveis à luz.
- Optoeletrônica – campo de estudo dos dispositivos sensíveis à luz.

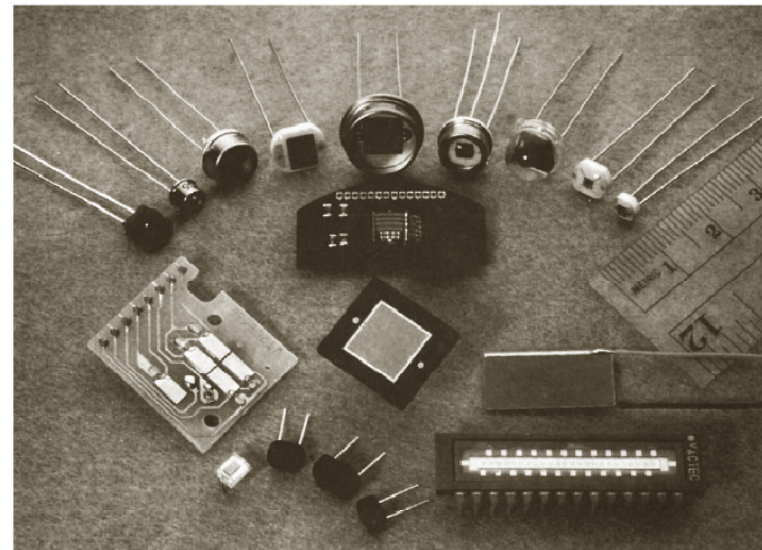
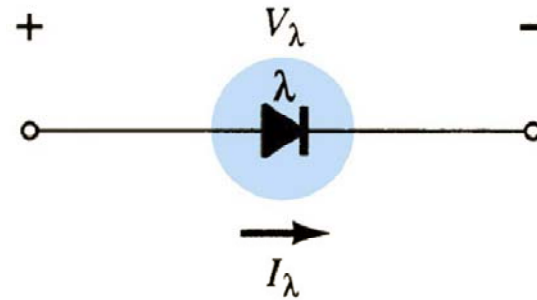
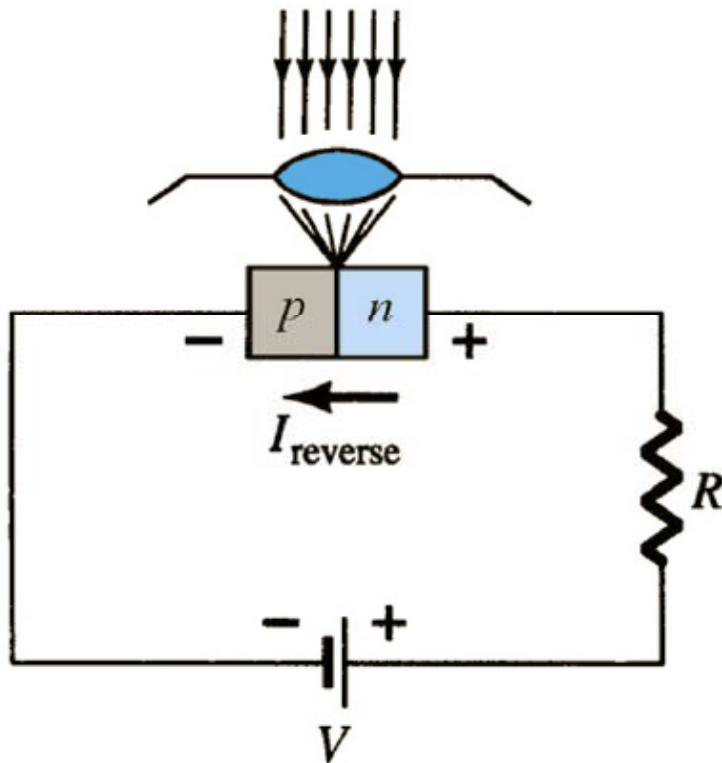

Fotodiodos

Curvas características dos fotodiodos:

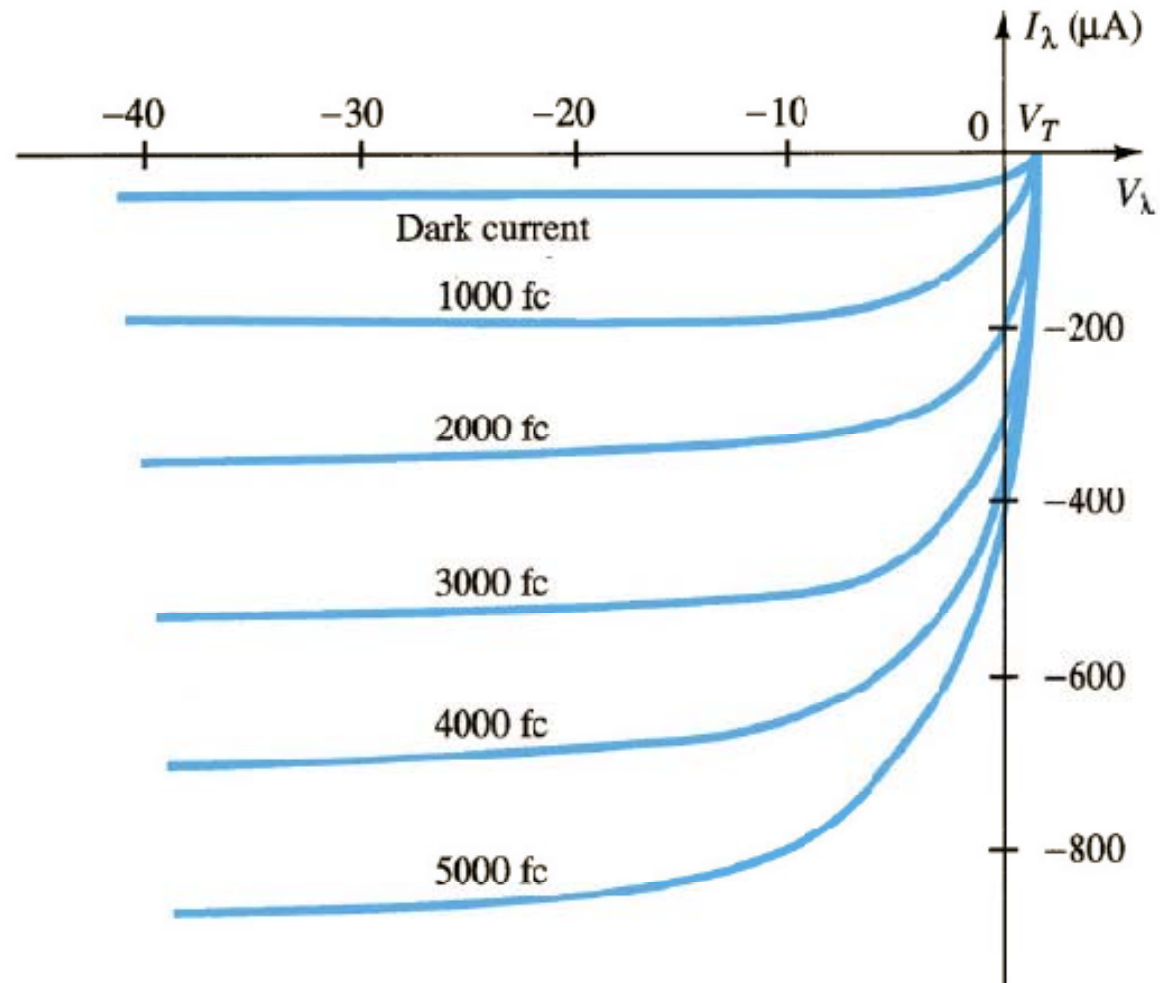

Fotodiodos

Resposta espectral de fotodiodos:

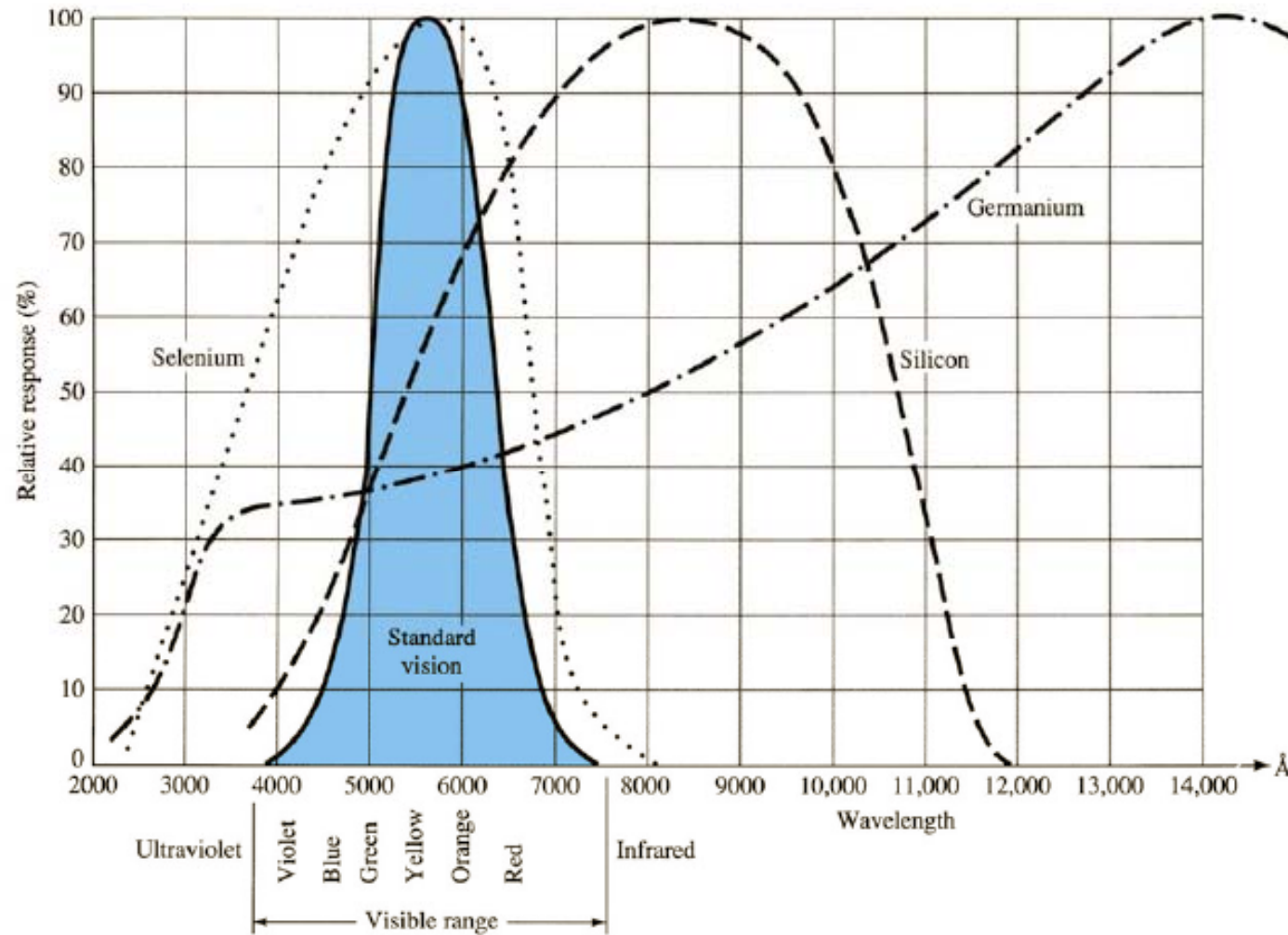

Fotodiodos

Exemplo de aplicação:

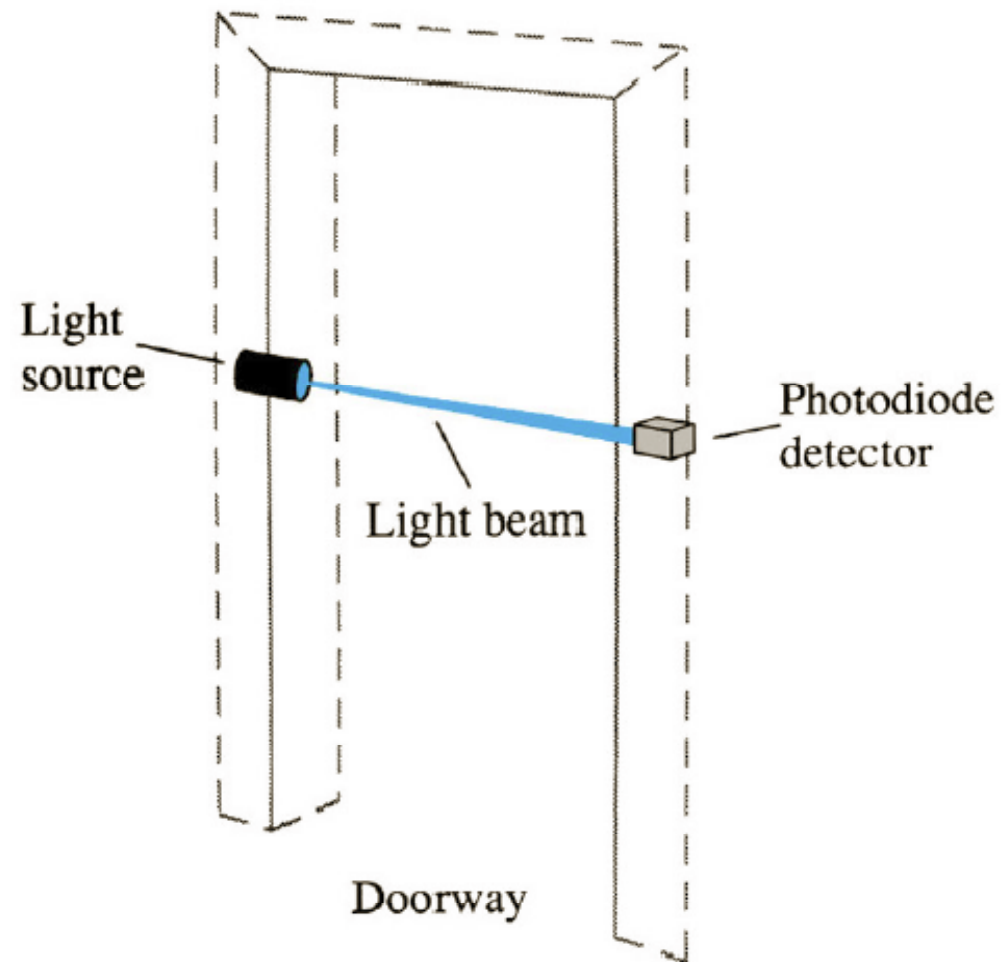

Fototransistor

Fototransistor:

- São transistores sensíveis à luz.

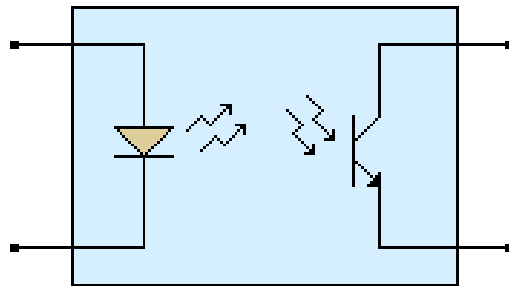

Optoacopladores

Optoacoplador:

- São dispositivos que possuem no mesmo encapsulamento um fotodiodo e um fototransistor (ou tiristor), montados de maneira a permitirem o acoplamento óptico entre os dois.
- Usados para isolação entre circuitos, pois não ocorre ligação elétrica entre os circuitos, por exemplo para transmissão de dados.

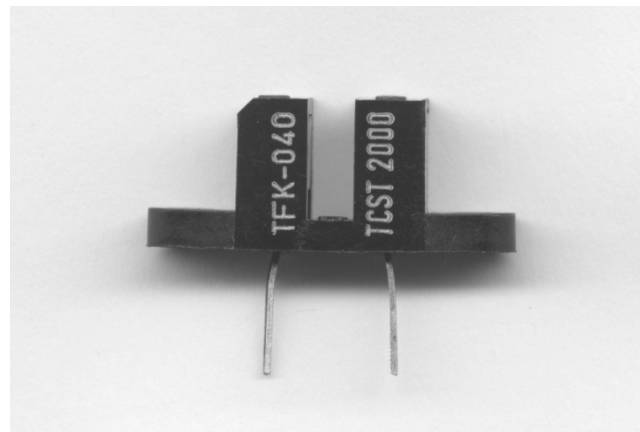

Optoacopladores



4N25M, 4N26M, 4N27M, 4N28M, 4N35M, 4N36M, 4N37M,
H11A1M, H11A2M, H11A3M, H11A4M, H11A5M
General Purpose 6-Pin Phototransistor Optocouplers

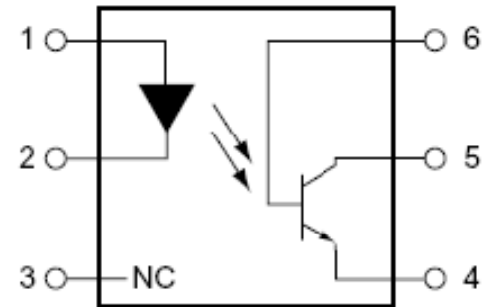

- PIN 1. ANODE
- 2. CATHODE
- 3. NO CONNECTION
- 4. EMITTER
- 5. COLLECTOR
- 6. BASE

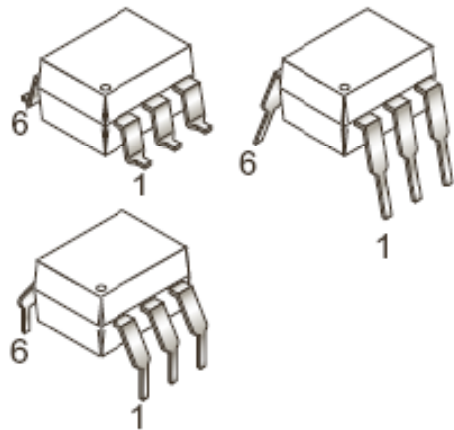

TEST CIRCUIT

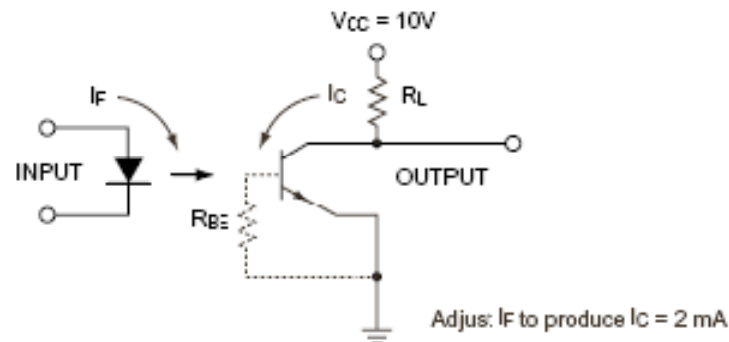

WAVE FORMS

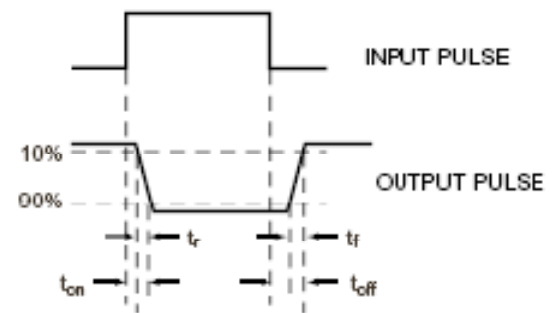

Optoacopladores

Optoacoplador com saída tiristorizada:

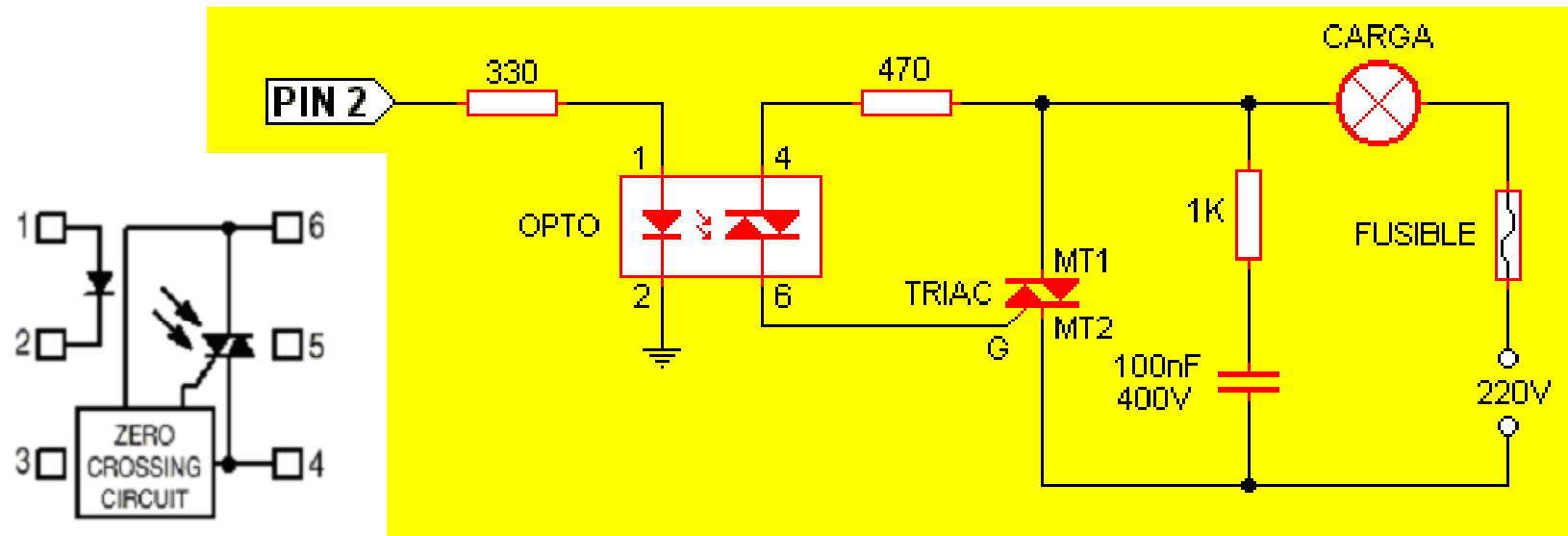

1. ANODE
2. CATHODE
3. NC
4. MAIN TERMINAL
5. SUBSTRATE
DO NOT CONNECT
6. MAIN TERMINAL

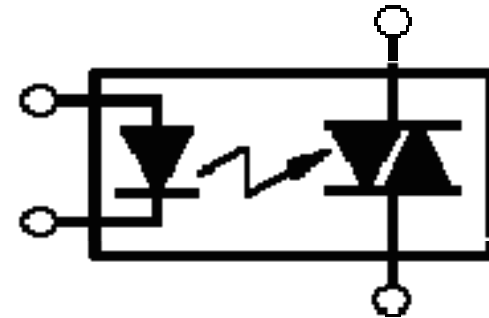

Células solares

Células solares:

- São dispositivos construídos a partir de materiais semicondutores e que são sensíveis à luz.
- Geram potências da ordem de mW quando iluminados.

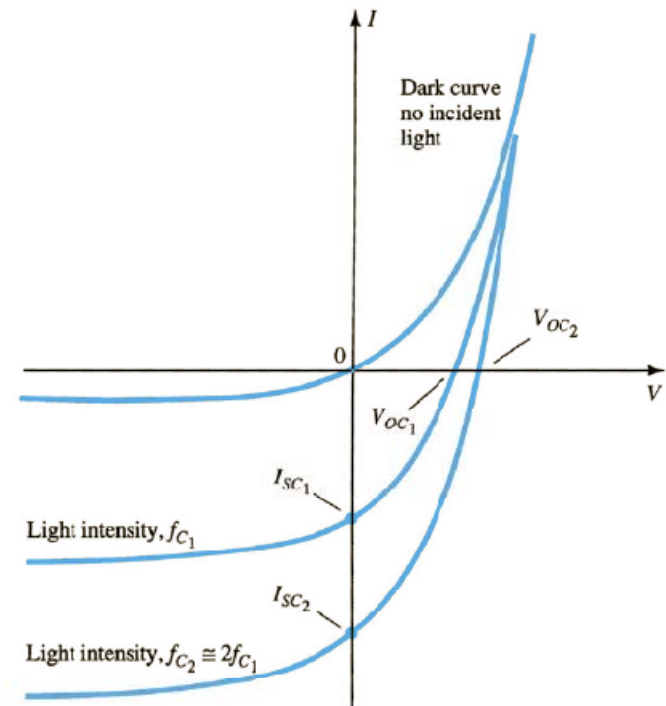
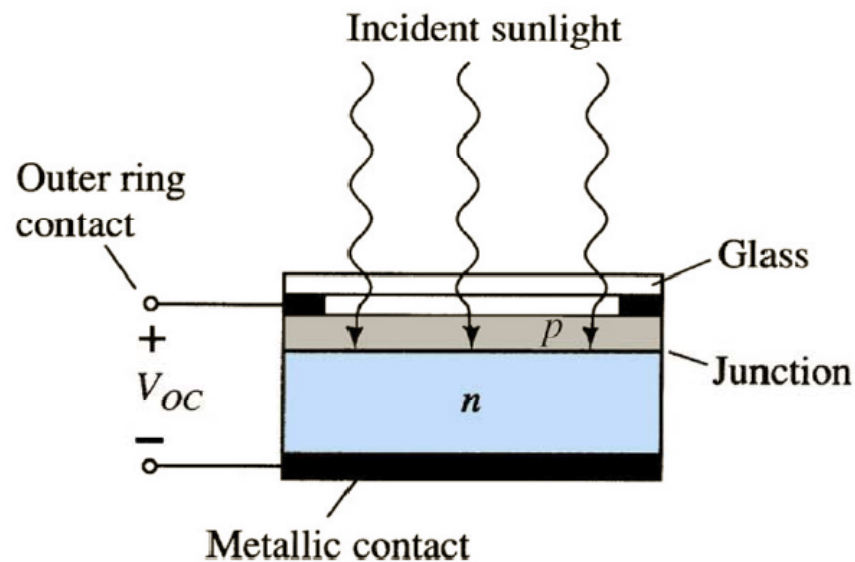

Células solares

Células solares:

- São dispositivos construídos a partir de materiais semicondutores e que são sensíveis à luz.
- Geram potências da ordem de mW quando iluminados.

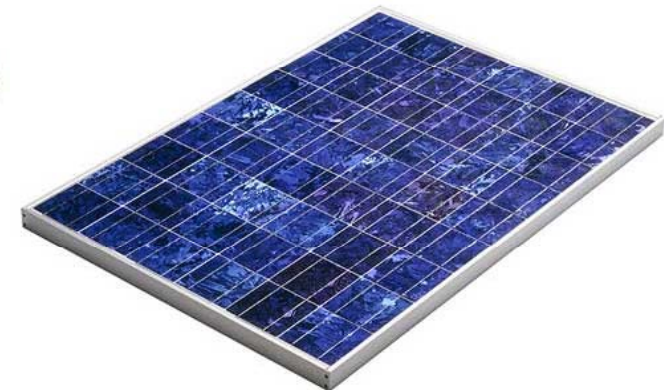
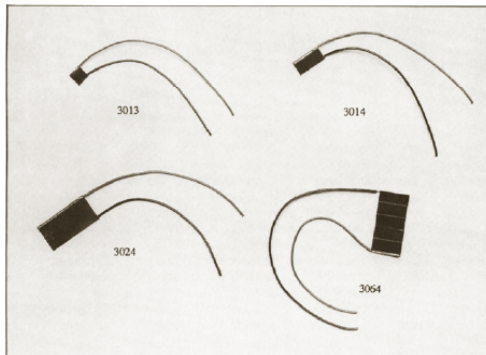

Na próxima aula

Seqüência de conteúdos:

1. Diodos zener;
2. Reguladores com diodos zener.