

Instituto Federal de Educação, Ciência e Tecnologia de Santa Catarina

Departamento Acadêmico de Eletrônica

Eletrônica de Potência

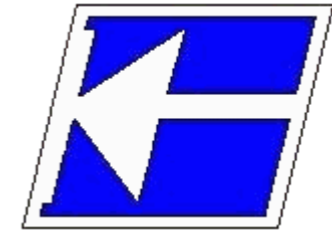

Projeto de Conversores CC-CC Integrados

Prof. Clovis Antonio Petry.

Florianópolis, setembro de 2014.

Capítulo 9 - Conversores cc-cc:

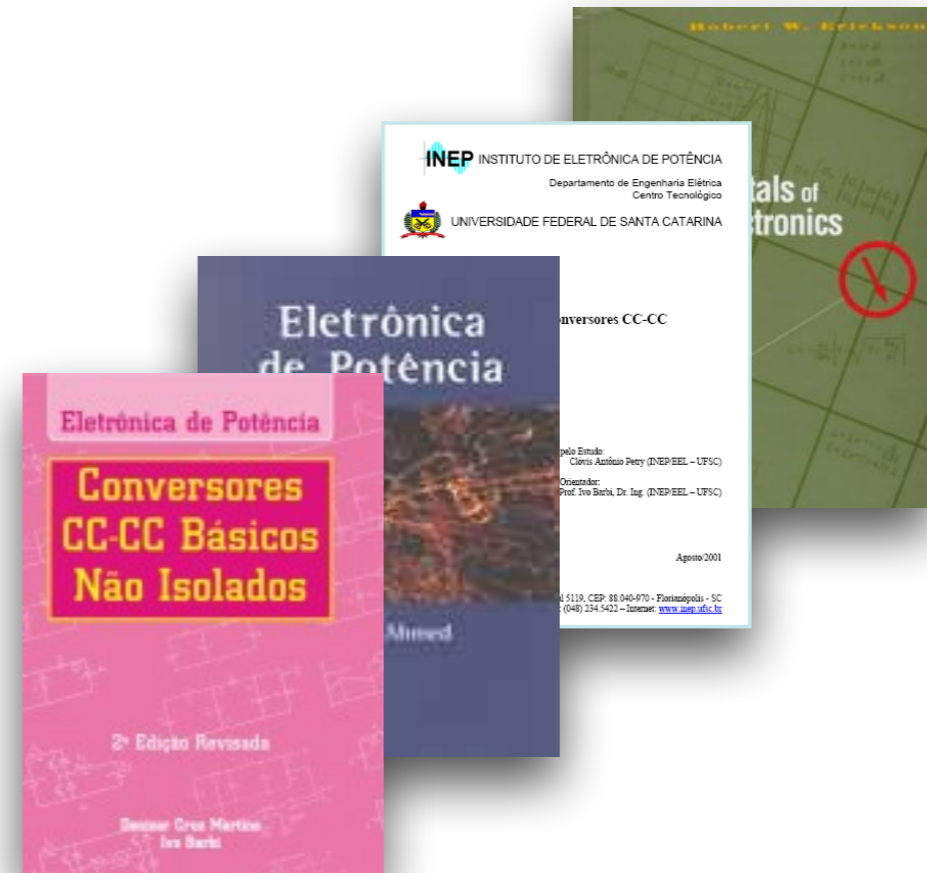

- Projeto de conversores cc-cc integrados.



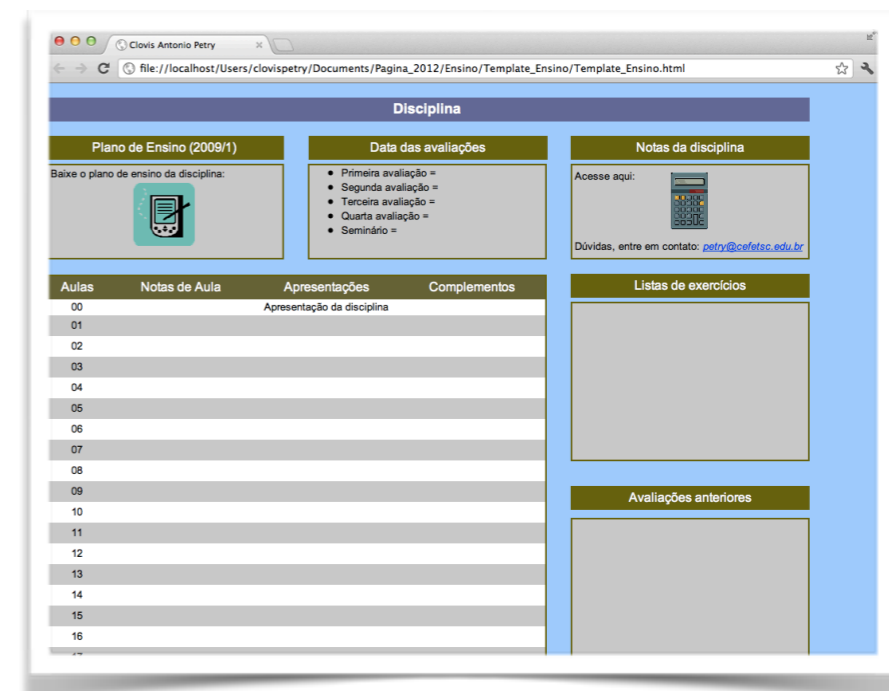
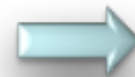

www.ProfessorPetry.com.br

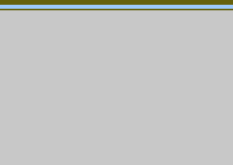

Screenshot of a web browser showing a course page. The browser address bar shows the file path: file:///localhost/Users/clovispetry/Documents/Pagina_2012/Ensino/Template_Ensino/Template_Ensino.html. The page title is 'Disciplina'. The content is organized into several sections:

- Plano de Ensino (2009/1)**: Baixe o plano de ensino da disciplina: 
- Data das avaliações**:
 - Primeira avaliação =
 - Segunda avaliação =
 - Terceira avaliação =
 - Quarta avaliação =
 - Seminário =
- Notas da disciplina**: Acesse aqui: 
Dúvidas, entre em contato: petry@cefetsc.edu.br
- Aulas**:

Aulas	Notas de Aula	Apresentações	Complementos
00		Apresentação da disciplina	
01			
02			
03			
04			
05			
06			
07			
08			
09			
10			
11			
12			
13			
14			
15			
16			
- Listas de exercícios**: 
- Avaliações anteriores**: 

Conversores cc-cc integrados:

- O circuito integrado LM1575;
- Exemplo de projeto online;
- Exemplo de projeto com o LM1575;
- Exercício de projeto.

LM1575/LM2575/LM2575HV SIMPLE SWITCHER® 1A Step-Down Voltage Regulator

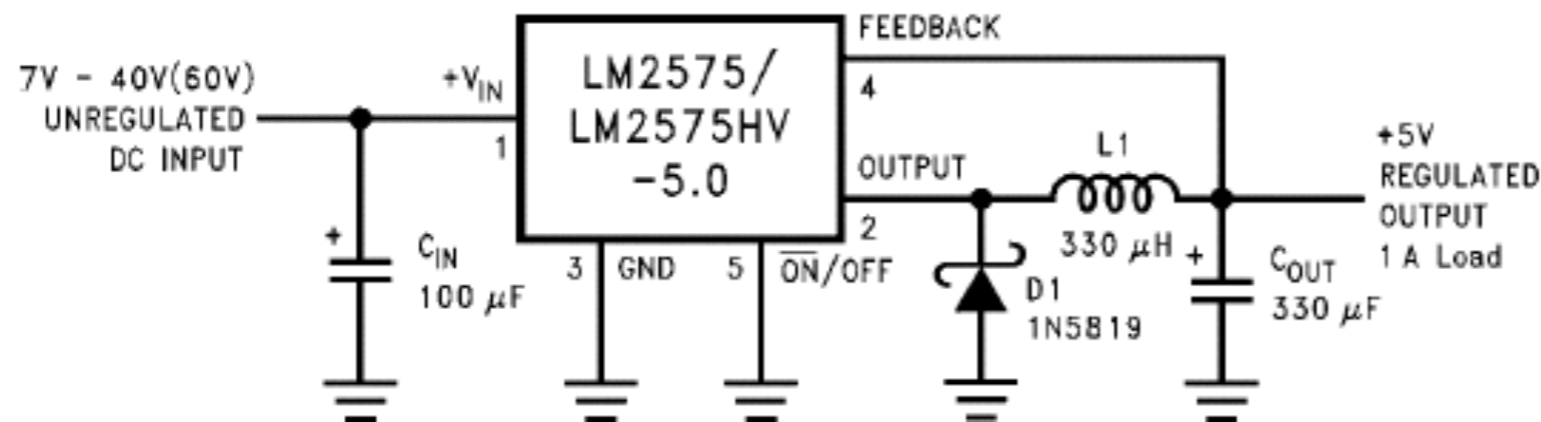

1147501

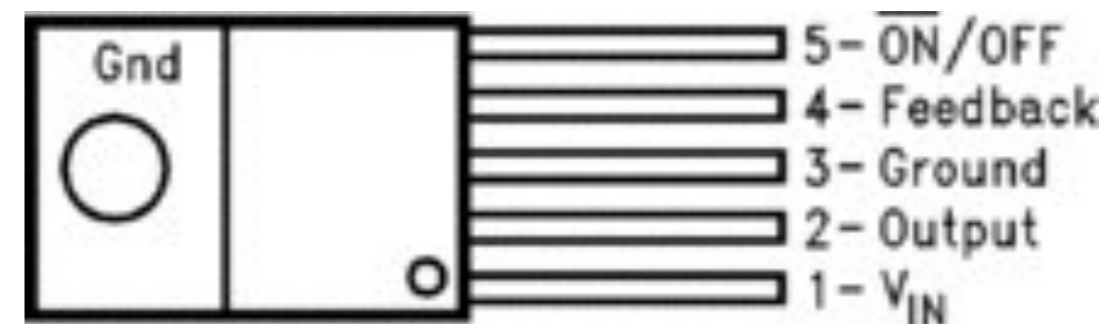

O Integrado LM1575

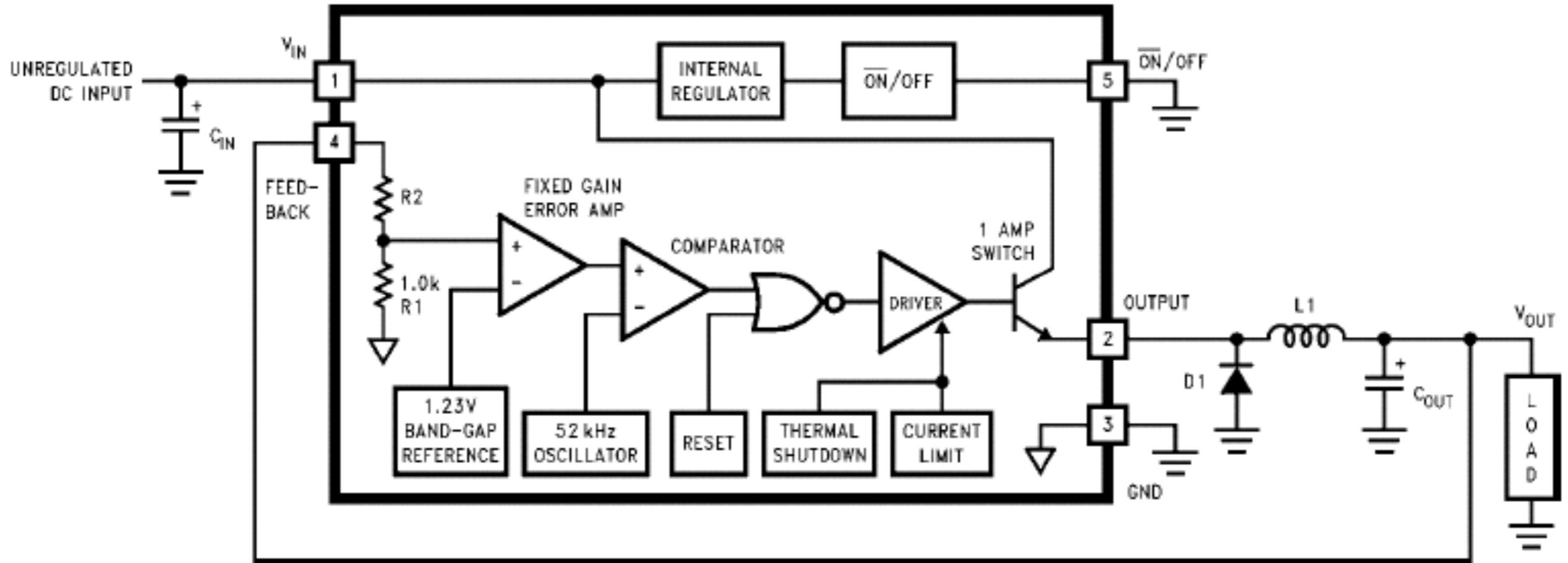

0 Integrado LM1575

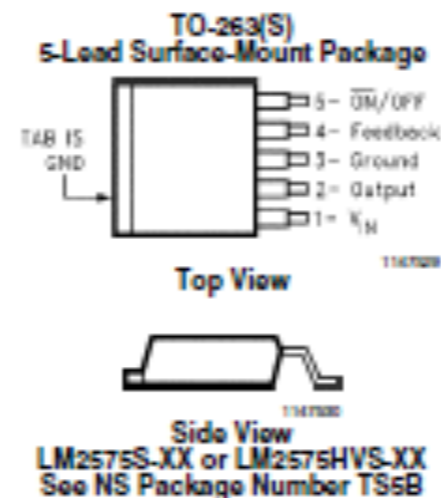
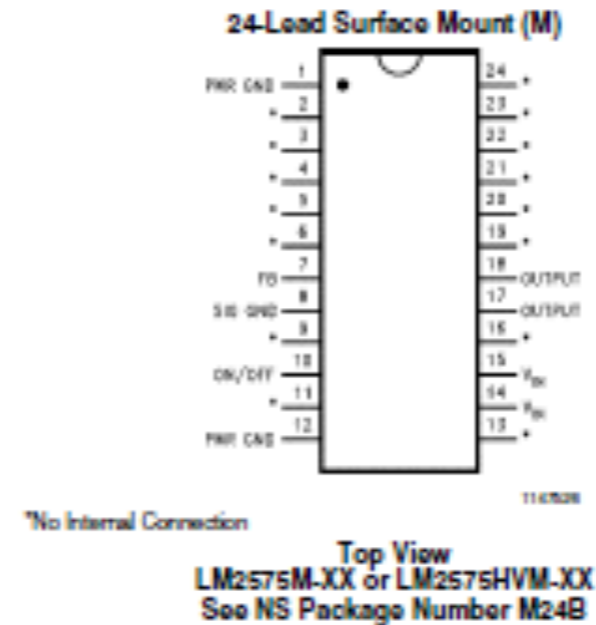
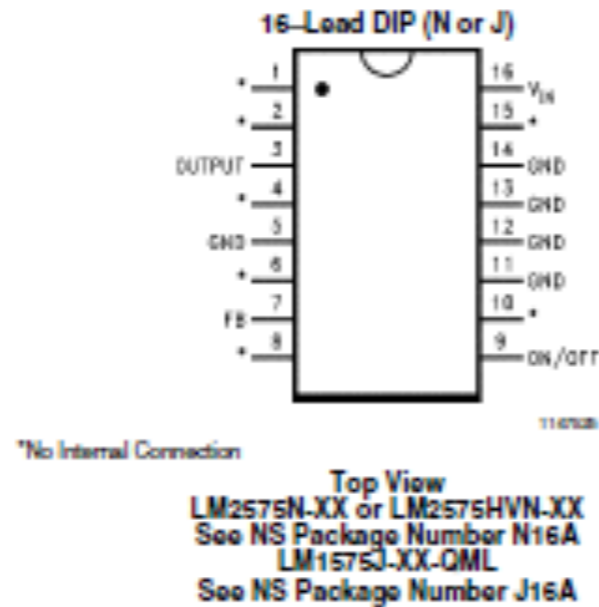
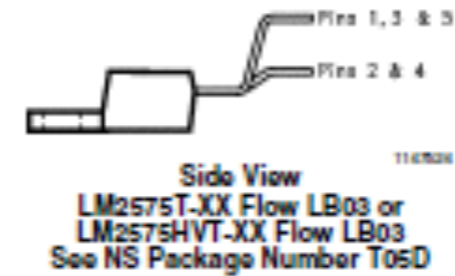
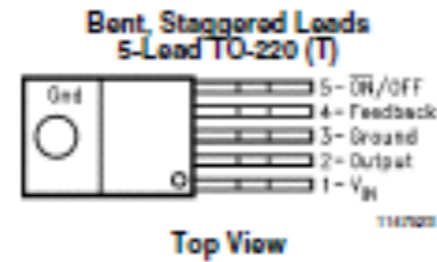
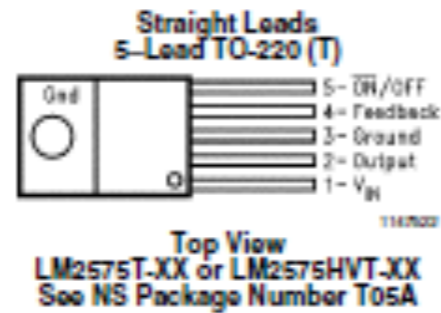

0 Integrado LM1575

Fixed Output Voltage Versions

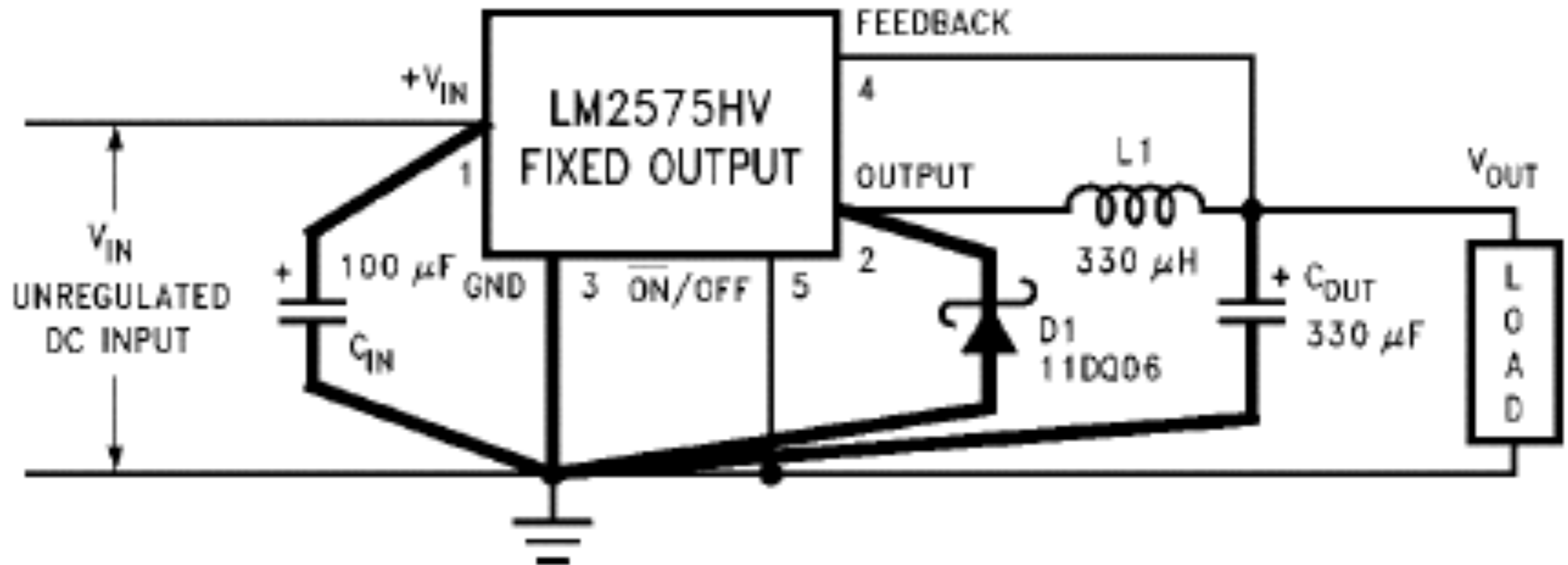

Saída de tensão fixa

0 Integrado LM1575

Adjustable Output Voltage Version

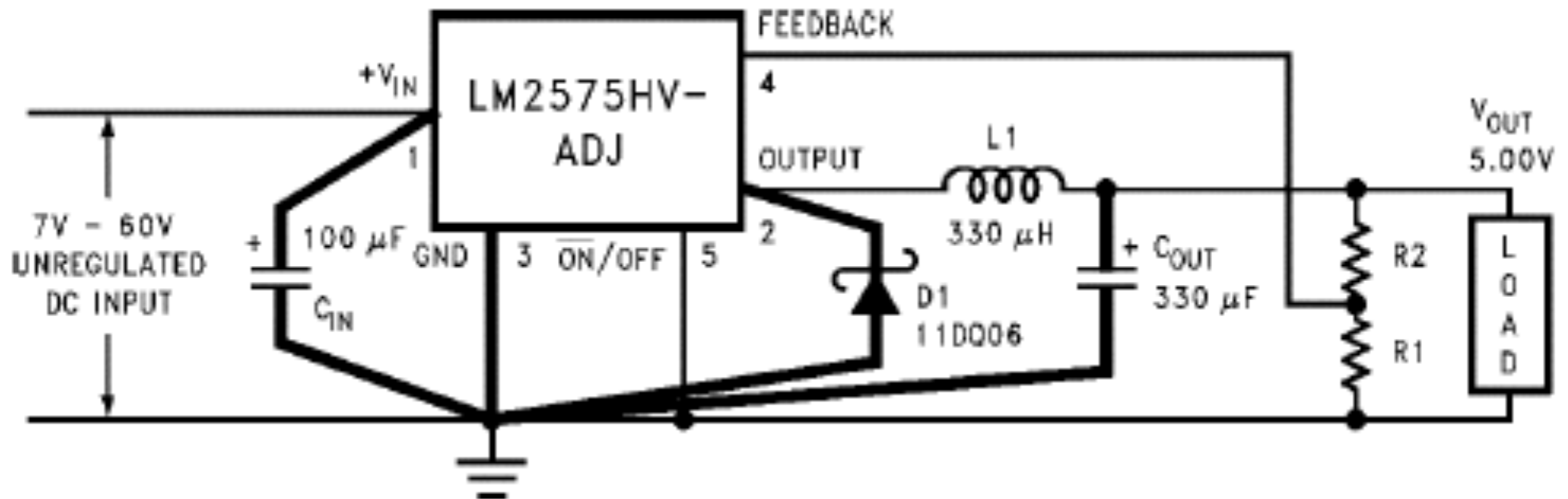

Saída de tensão ajustável

0 Integrado LM1575

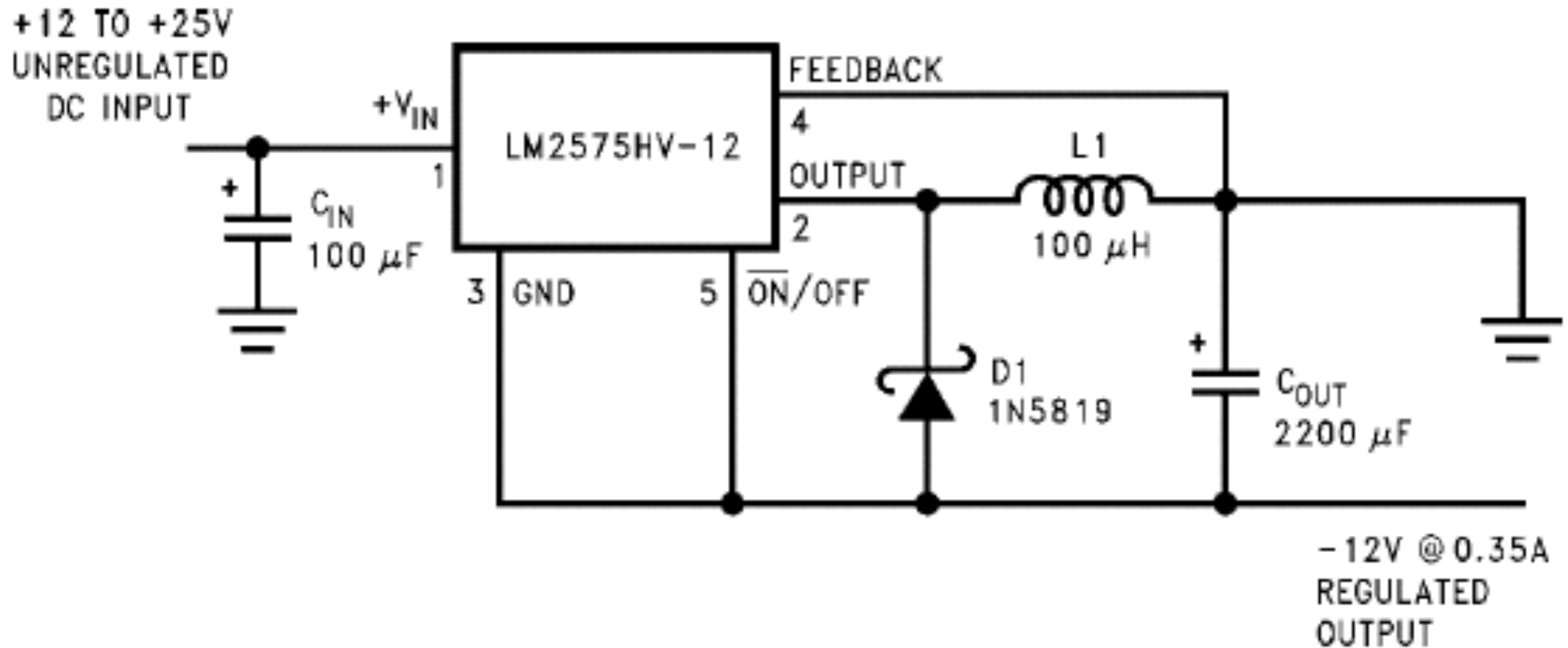

Buck-Boost - Entrada positiva/saída negativa

O Integrado LM1575

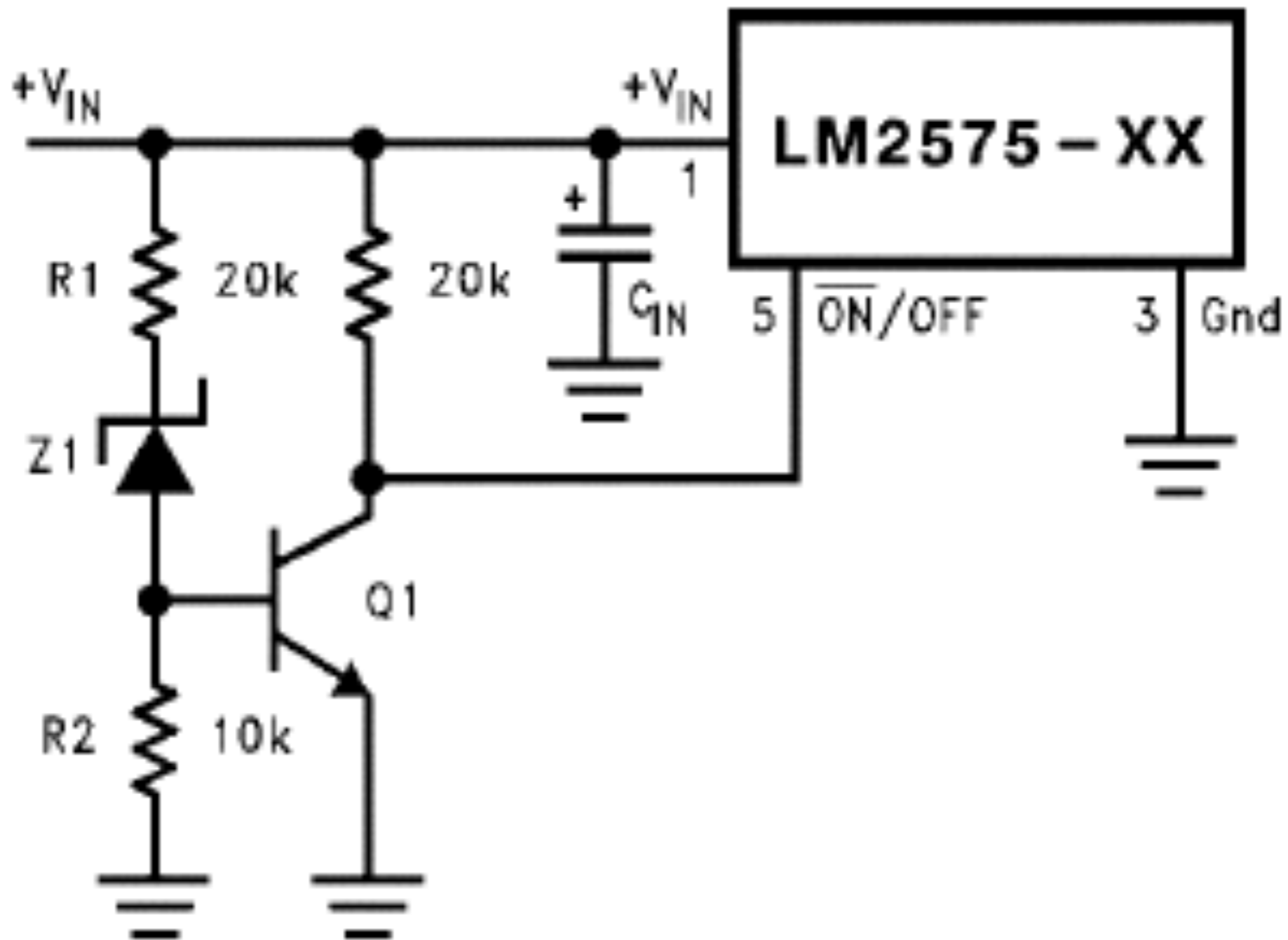

Undervoltage lockout - proteção contra subtensão

Exemplo de Projeto Online

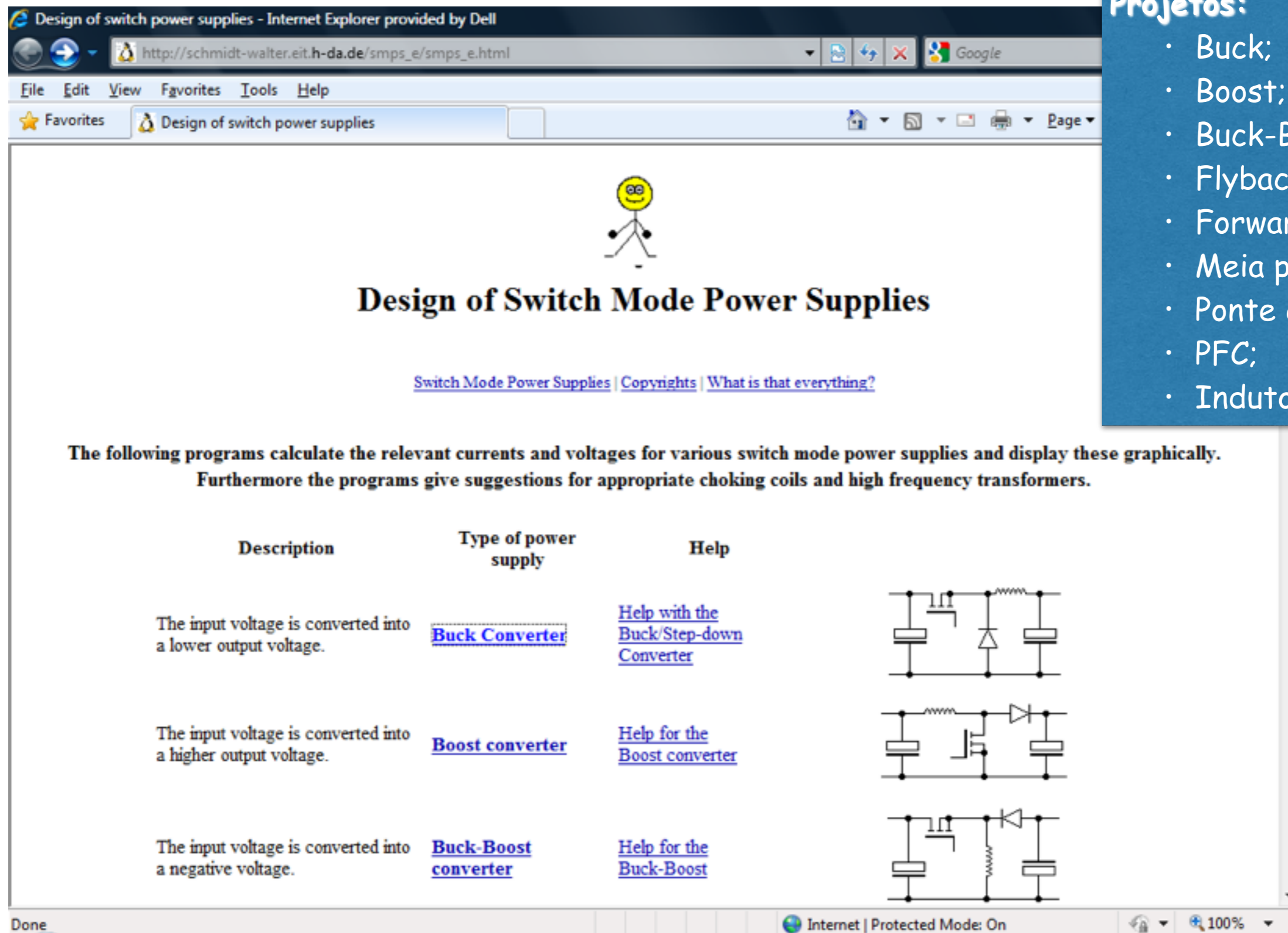

Design of switch power supplies - Internet Explorer provided by Dell

http://schmidt-walter.eit.h-da.de/smpps_e/smpps_e.html

File Edit View Favorites Tools Help

Design of switch power supplies



Design of Switch Mode Power Supplies

[Switch Mode Power Supplies](#) | [Copyrights](#) | [What is that everything?](#)

The following programs calculate the relevant currents and voltages for various switch mode power supplies and display these graphically.
Furthermore the programs give suggestions for appropriate choking coils and high frequency transformers.

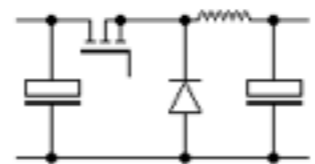
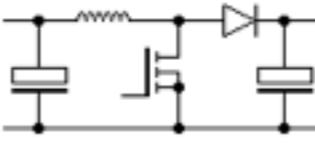
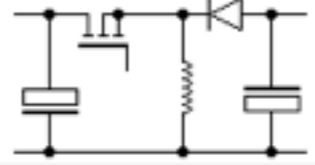
Description	Type of power supply	Help	
The input voltage is converted into a lower output voltage.	Buck Converter	Help with the Buck/Step-down Converter	
The input voltage is converted into a higher output voltage.	Boost converter	Help for the Boost converter	
The input voltage is converted into a negative voltage.	Buck-Boost converter	Help for the Buck-Boost	

Done Internet | Protected Mode: On 100%

Projetos:

- Buck;
- Boost;
- Buck-Boost;
- Flyback;
- Forward;
- Meia ponte;
- Ponte completa;
- PFC;
- Indutores.

Exemplo de Projeto Online

Buck Converter

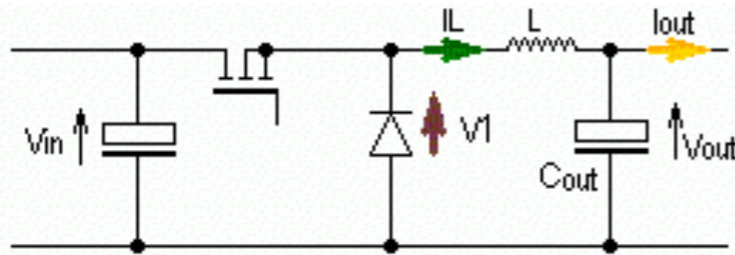

Buck Converter

$V_{in_min} = 10.0V$	$V_{in_max} = 14.0V$	$V_{in} = 12.0V$
$V_{out} = 5.0V$	$I_{out} = 1.0A$	$f = 50.0kHz$
$L = 174.4\mu H$	$\Delta I_L \text{ for } V_{in_max} = 0.4A$	

V_{in_min} / V	V_{in_max} / V	V_{in} / V for the calculation
10	14	
V_{out} / V	I_{out} / A	f / kHz
5	1	50
<input checked="" type="checkbox"/> Proposal	L / H	$\Delta I_L / A$ for V_{in_max}
		Coil Data

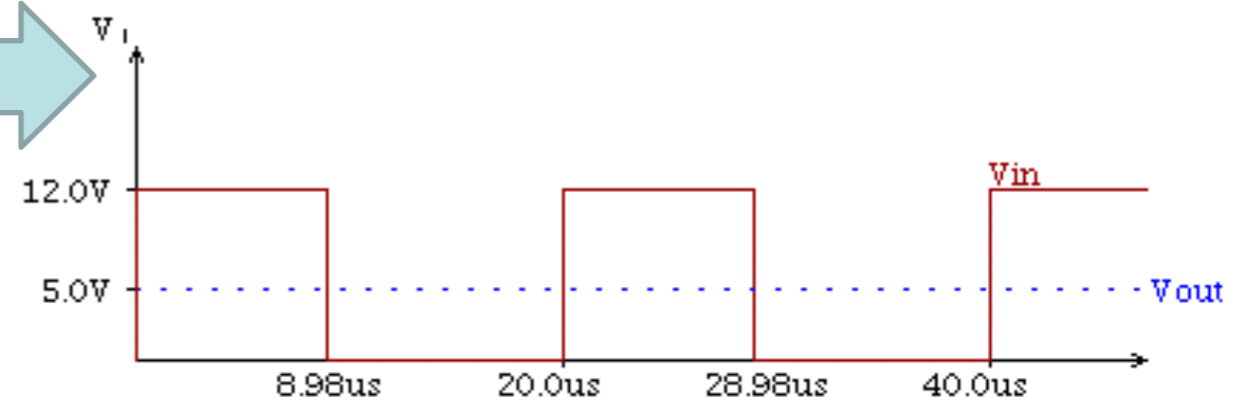

<input checked="" type="checkbox"/> Proposal	L / H	$\Delta I_L / A$ for V_{in_max}
	174.4E-6	0.4
		Coil Data

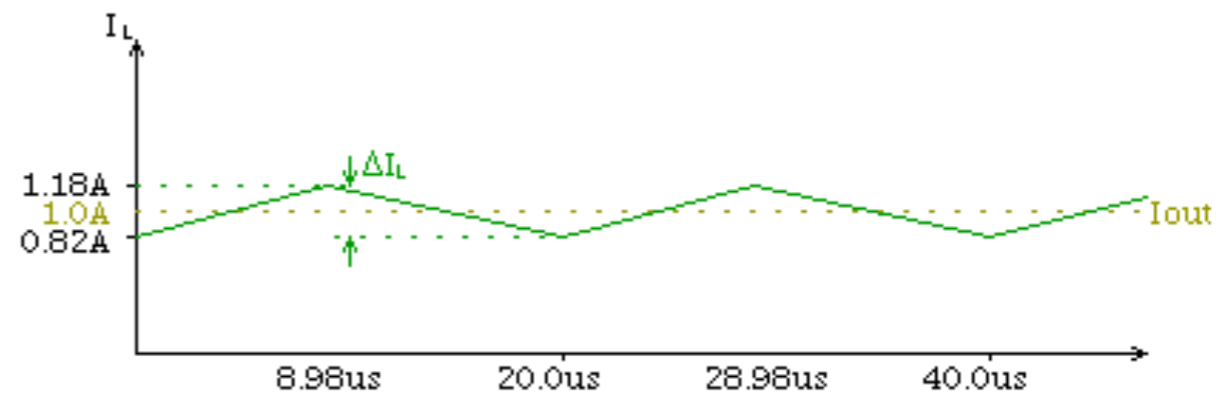

Exemplo de Projeto com o LM1575

Dados de entrada:

- Tensão de entrada = 10 a 14 V;
- Tensão de saída = 5 V;
- Corrente de saída = 1 A;
- Freqüência de comutação = 50 kHz.

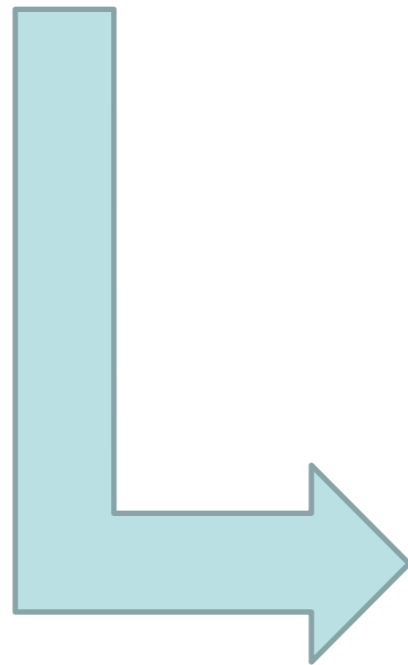
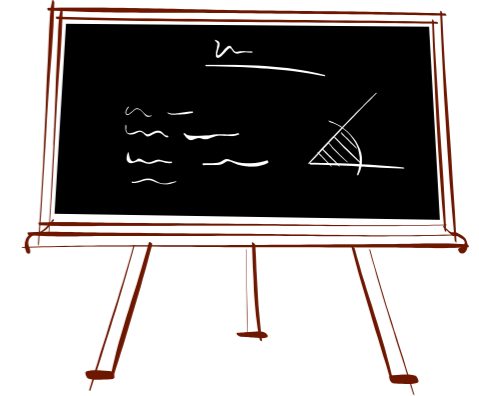

LM1575.pdf (PROTEGIDO) - Adobe Reader

Arquivo Editar Visualizar Documento Ferramentas Janela Ajuda

13 / 28 107%

Localizar

LM2575 Series Buck Regulator Design Procedure

PROCEDURE (Fixed Output Voltage Versions)	EXAMPLE (Fixed Output Voltage Versions)
<p>Given: V_{OUT} = Regulated Output Voltage (3.3V, 5V, 12V, or 15V) $V_{IN(Max)}$ = Maximum Input Voltage $I_{LOAD(Max)}$ = Maximum Load Current</p> <p>1. Inductor Selection (L_1)</p> <p>A. Select the correct inductor value selection guide from Figures 3, 4, 5, 6 (Output voltages of 3.3V, 5V, 12V or 15V respectively). For other output voltages, see the design procedure for the adjustable version.</p> <p>B. From the inductor value selection guide, identify the inductance region intersected by $V_{IN(Max)}$ and $I_{LOAD(Max)}$, and note the inductor code for that region.</p> <p>C. Identify the inductor value from the inductor code, and select an appropriate inductor from the table shown in Figure 9. Part numbers are listed for three inductor manufacturers. The inductor chosen must be rated for operation at the LM2575 switching frequency (52 kHz) and for a current rating of $1.15 \times I_{LOAD}$. For additional inductor information, see the inductor section in the Application Hints section of this data sheet.</p> <p>2. Output Capacitor Selection (C_{OUT})</p> <p>A. The value of the output capacitor together with the inductor defines the dominate pole-pair of the switching regulator loop. For stable operation and an acceptable output ripple voltage, (approximately 1% of the output voltage) a value between 100 μF and 470 μF is recommended.</p> <p>B. The capacitor's voltage rating should be at least 1.5 times greater than the output voltage. For a 5V regulator, a rating of at least 8V is appropriate, and a 10V or 15V rating is recommended. Higher voltage electrolytic capacitors generally have lower ESR numbers, and for this reason it may be necessary to select a ca-</p>	<p>Given: $V_{OUT} = 5V$ $V_{IN(Max)} = 20V$ $I_{LOAD(Max)} = 0.8A$</p> <p>1. Inductor Selection (L_1)</p> <p>A. Use the selection guide shown in Figure 4.</p> <p>B. From the selection guide, the inductance area intersected by the 20V line and 0.8A line is L330.</p> <p>C. Inductor value required is 330 μH. From the table in Figure 9, choose AIE 415-0926, Pulse Engineering PE-52627, or RL1952.</p> <p>2. Output Capacitor Selection (C_{OUT})</p> <p>A. $C_{OUT} = 100 \mu$F to 470 μF standard aluminum electrolytic.</p> <p>B. Capacitor voltage rating = 20V.</p>

LM1575/LM2575/LM2575HV

Exercício de Projeto de Conversores Integrados

Projetar um conversor Buck com os dados abaixo:

- Tensão de entrada = 12 V;
- Tensão de saída = 3,3 V;
- Corrente de saída = 0,5 A;
- Frequência de comutação = 50 kHz.

Apresentar os resultados com o projeto online e com o projeto seguindo a metodologia do LM1575.

Próxima Aula

Conversores cc-cc:

- Conversores operando em malha fechada.

