

Instituto Federal de Educação, Ciência e Tecnologia de Santa Catarina

Departamento Acadêmico de Eletrônica

Eletrônica de Potência



# Semicondutores de Potência

## Diodos e Tiristores

Prof. Clovis Antonio Petry.

Florianópolis, outubro de 2015.

# Biografia para Esta Aula

## Capítulos 2 e 4:

- Diodos de potência;
- Dispositivos tiristores.



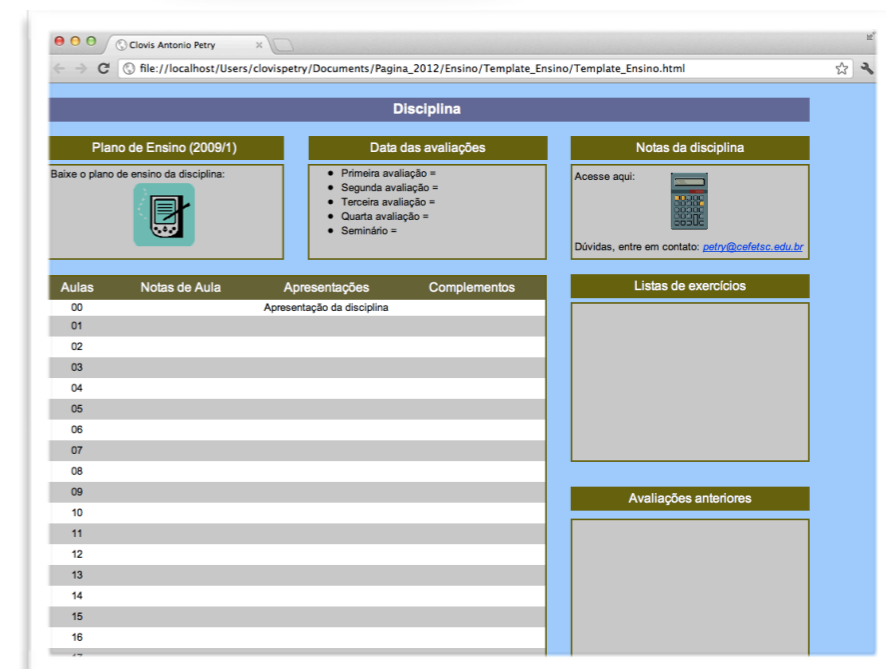

[www.ProfessorPetry.com.br](http://www.ProfessorPetry.com.br)



Clóvis Antonio Petry

file:///localhost/Users/clovispetry/Documents/Pagina\_2012/Ensino/Template\_Ensino/Template\_Ensino.html

### Disciplina

Plano de Ensino (2009/1)	Data das avaliações	Notas da disciplina		
Baixe o plano de ensino da disciplina: 	<ul style="list-style-type: none"><li>• Primeira avaliação =</li><li>• Segunda avaliação =</li><li>• Terceira avaliação =</li><li>• Quarta avaliação =</li><li>• Seminário =</li></ul>	Acesse aqui:  Dúvidas, entre em contato: <a href="mailto:petry@cefetsc.edu.br">petry@cefetsc.edu.br</a>		
Aulas	Notas de Aula	Apresentações	Complementos	Listas de exercicios
00		Apresentação da disciplina		
01				
02				
03				
04				
05				
06				
07				
08				
09				
10				
11				
12				
13				
14				
15				
16				

Avaliações anteriores

## Semicondutores de potência:

- Semicondutores para eletrônica de potência;
- Diodos ideais;
- Diodos reais;
- Comutação de diodos;
- Perdas em diodos;
- Características importantes de diodos;
- Tiristores;
- Tiristores ideais e reais;
- Comutação de tiristores;
- Perdas nos tiristores;
- Características importantes de tiristores;
- Acionamento de tiristores.

# Semicondutores de Potência

Semicondutores aplicados à eletrônica de potência:

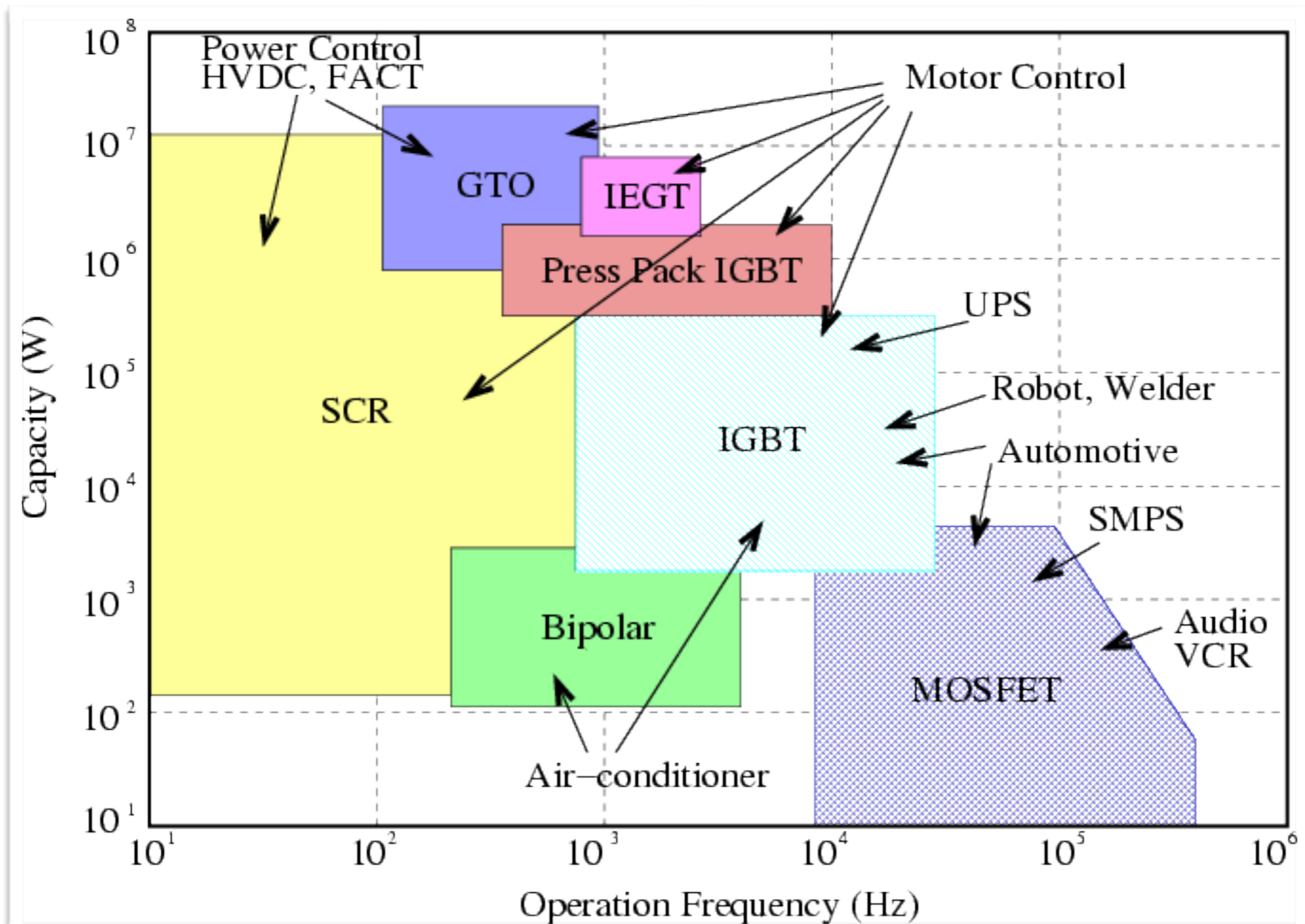

# Diodo Ideal x Diodo Real

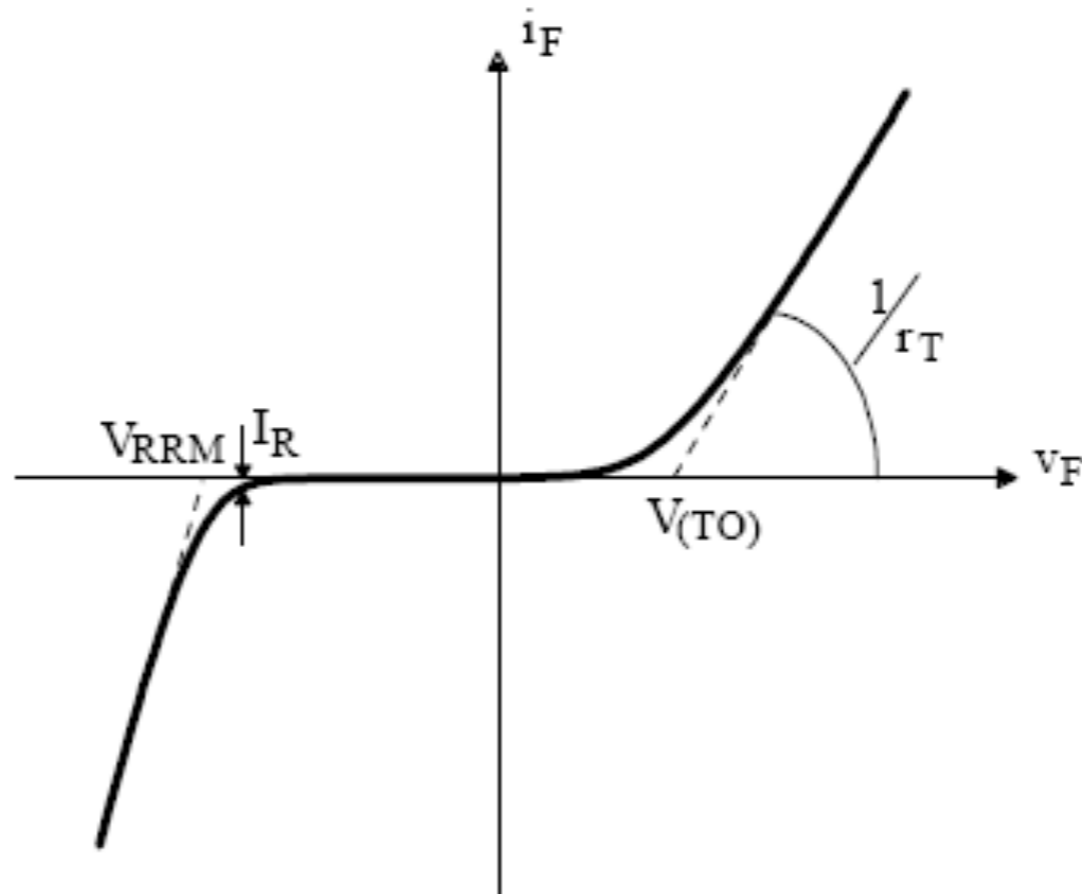
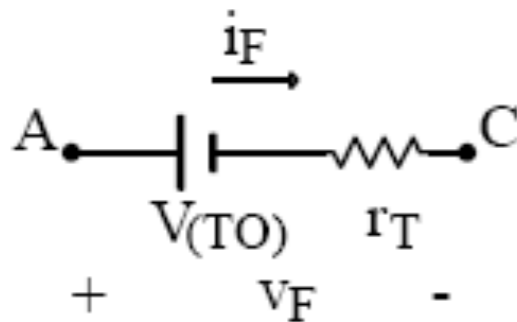
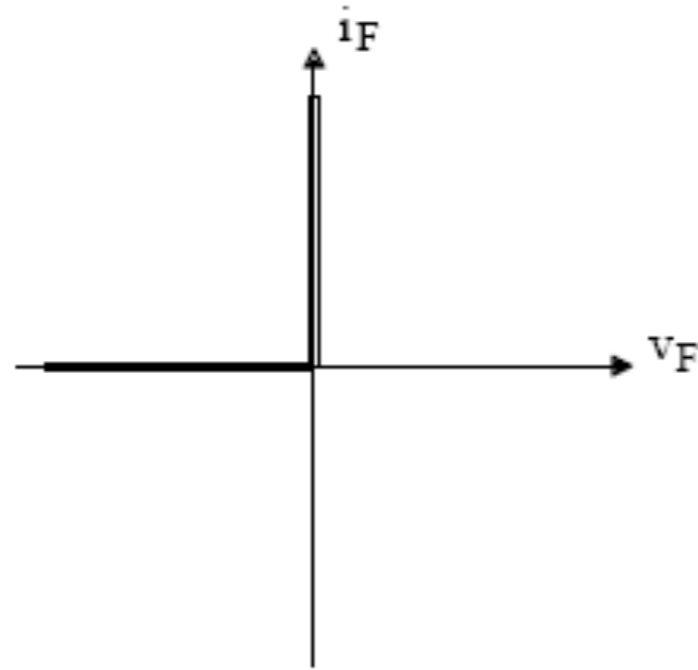
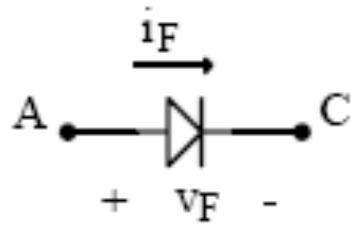

## Exemplo: Diodo SKN20/08

- $V_{RRM} = 800 \text{ V}$ ;
- $V_{(TO)} = 0,85 \text{ V}$ ;
- $r_T = 11 \text{ m}\Omega$ ;
- $I_{Dmed} = 20 \text{ A}$ ;
- $I_R = 0,15 \text{ mA}$ .

Característica estática

# Diodes Ideal x Diodes Real

## Demonstration

### Demo

- Diode curves:
  - Zener diode;
  - Signal diode;
  - Power diode.

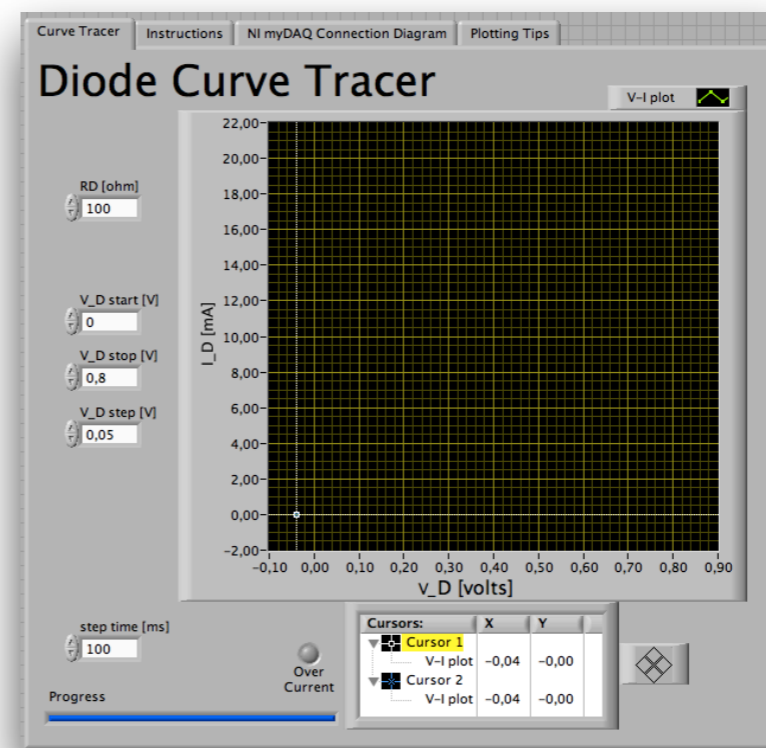

# Comutação de Diodos

Bloqueio:

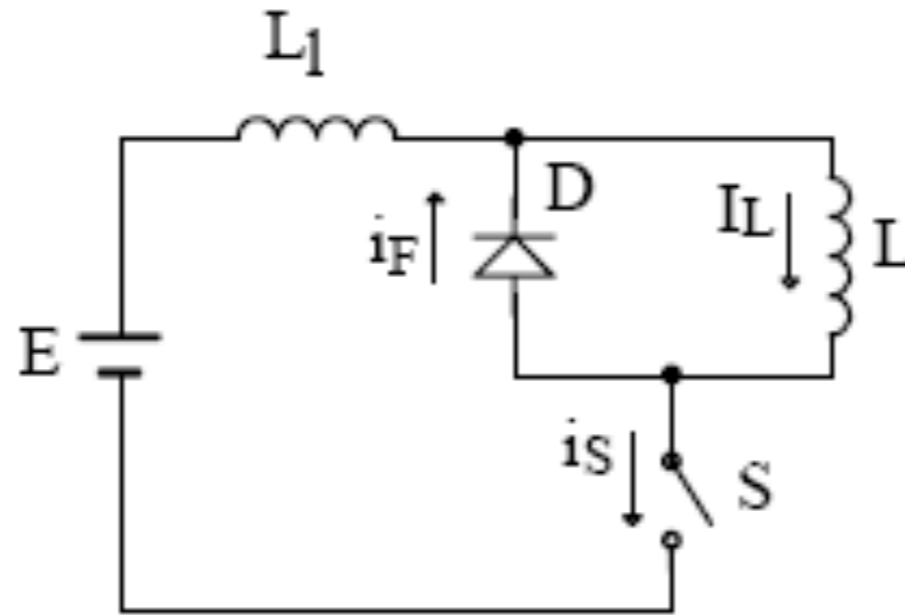

Circuito para estudo da comutação

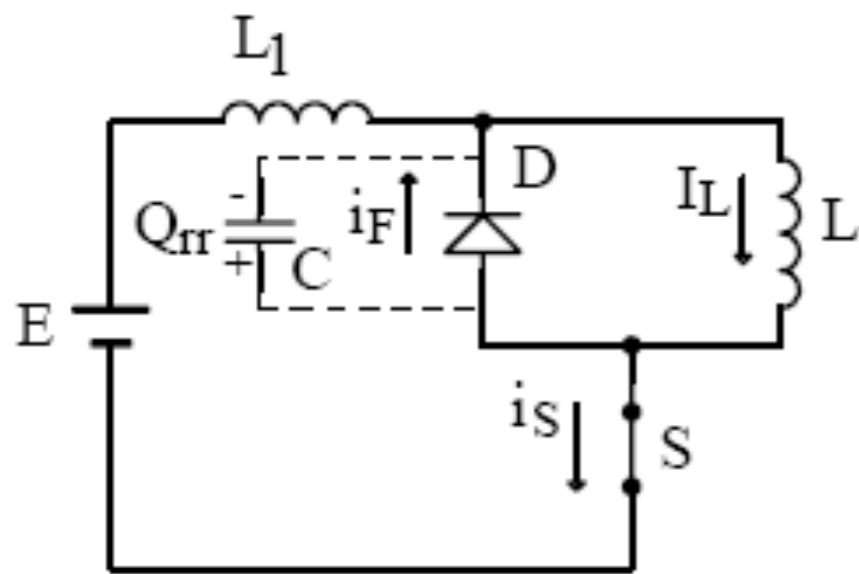

Primeira etapa de comutação

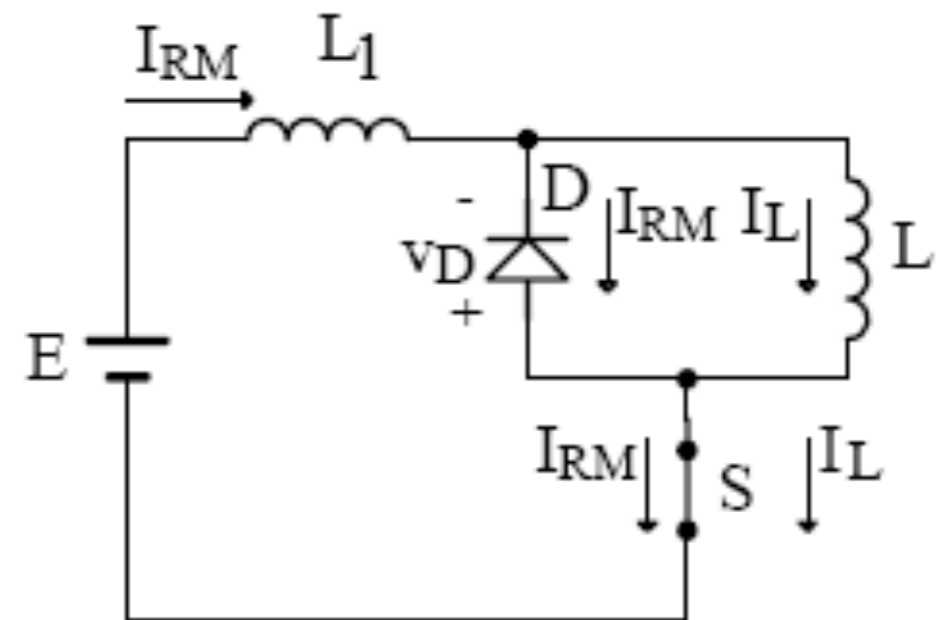

Segunda etapa de comutação

# Comutação de Diodos

Bloqueio:

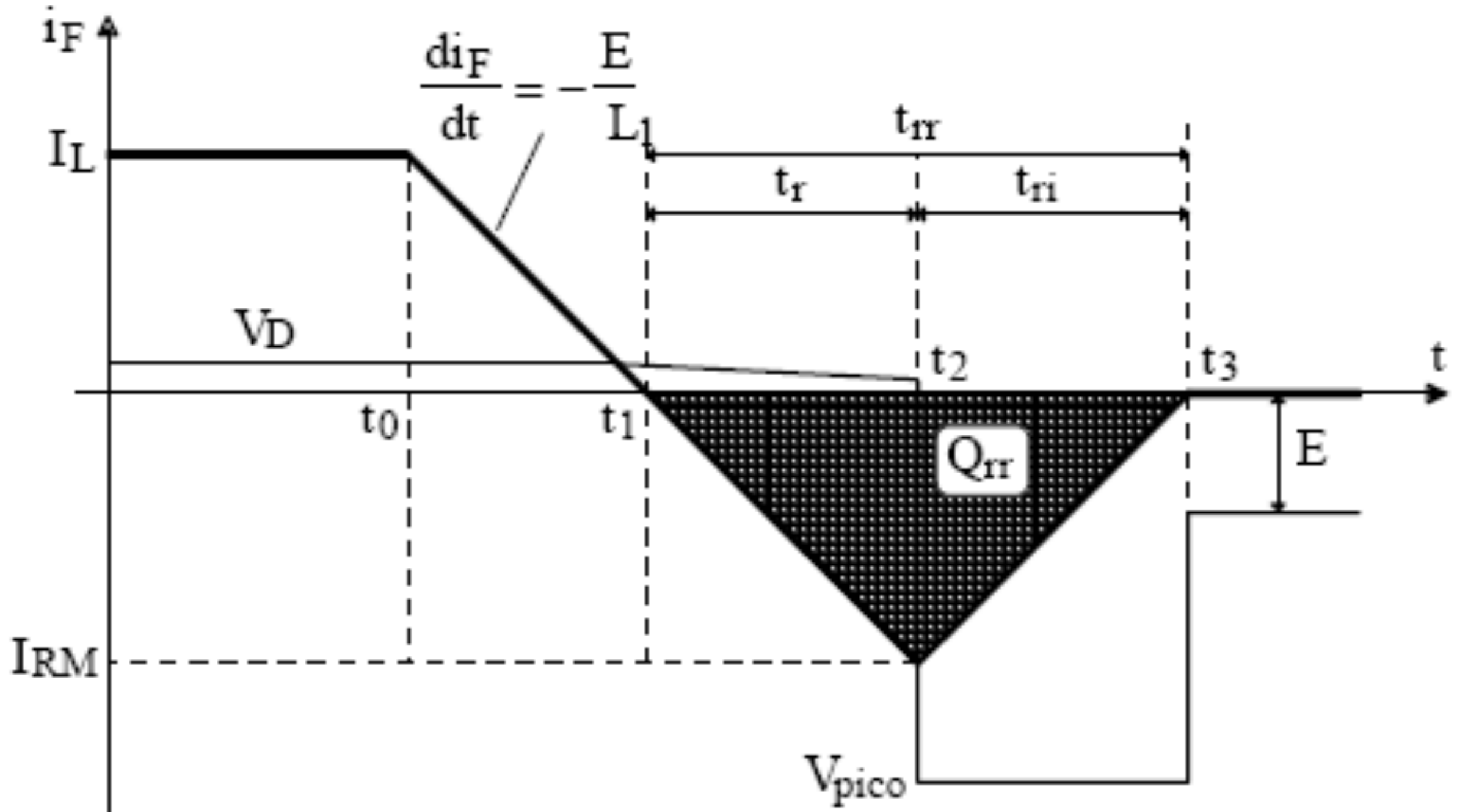

# Comutação de Diodos

Diodos de carbeto de silício (silicon carbide):

- Diminuem acentuadamente o fenômeno da recuperação reversa.

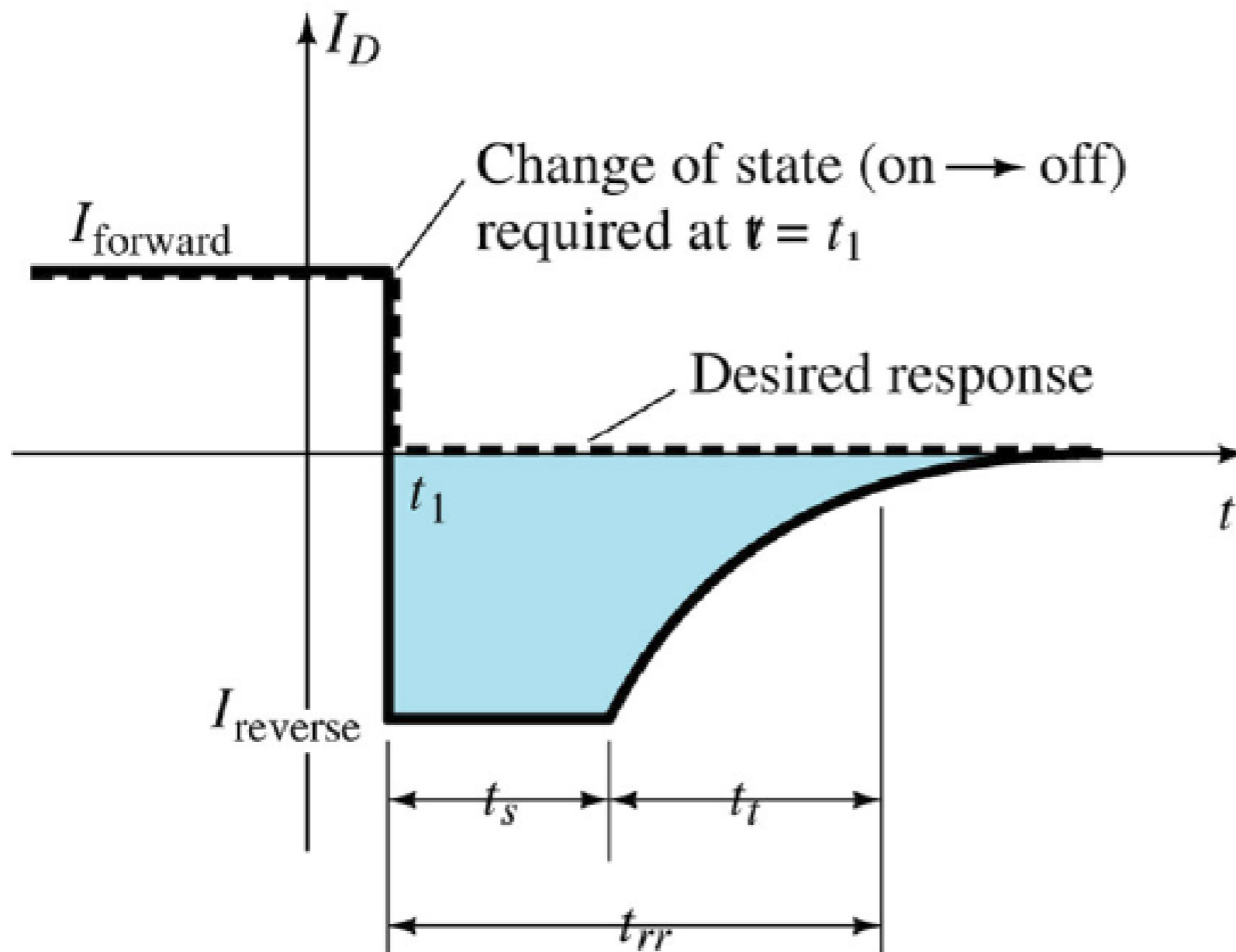

[www.infineon.com](http://www.infineon.com)

[www.cree.com](http://www.cree.com)

# Comutação de Diodos

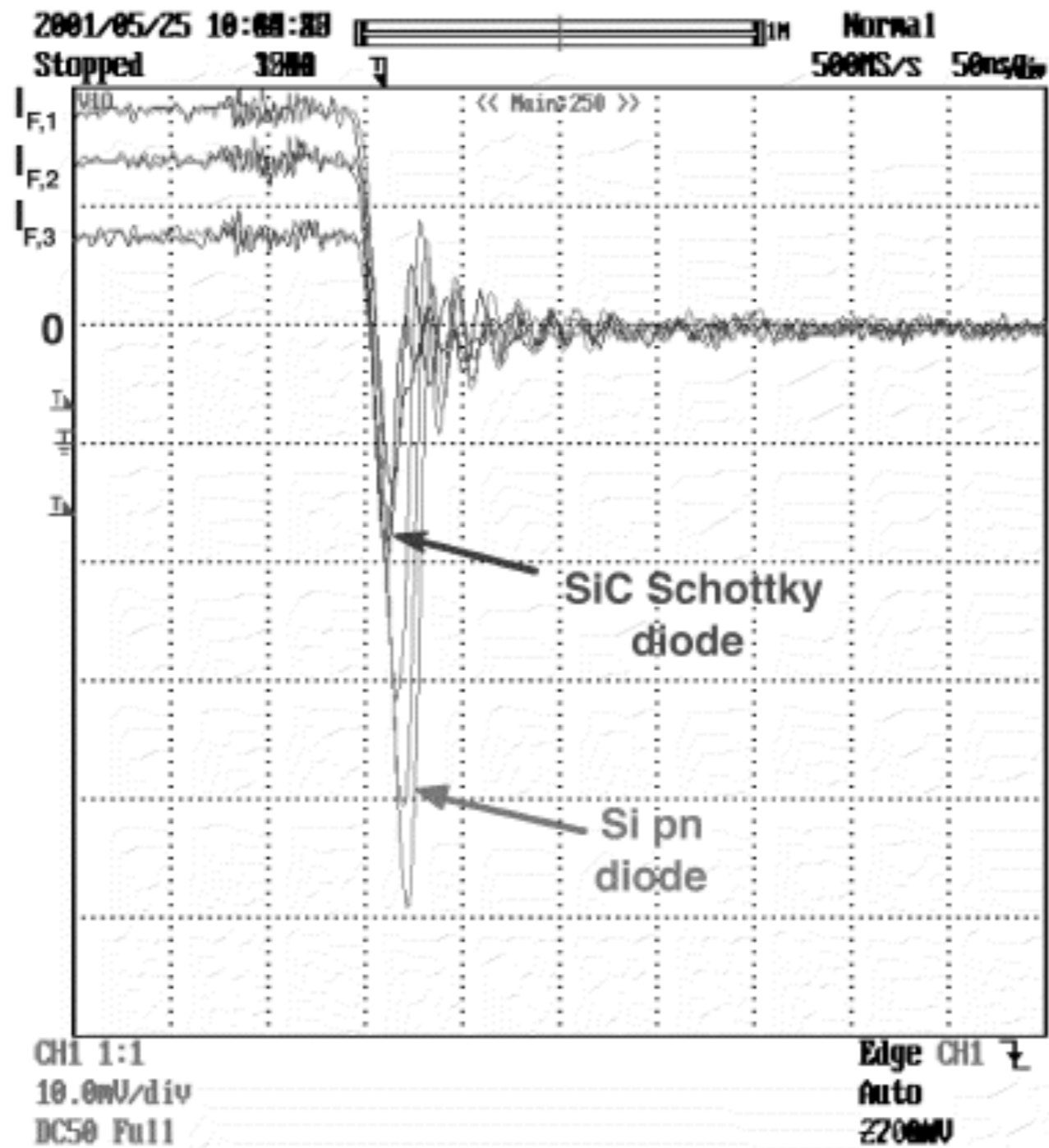

Fig. 5. Typical reverse recovery waveforms of the Si pn and SiC Schottky diode for three different forward currents (2 A/div.).

# Comutação de Diodos

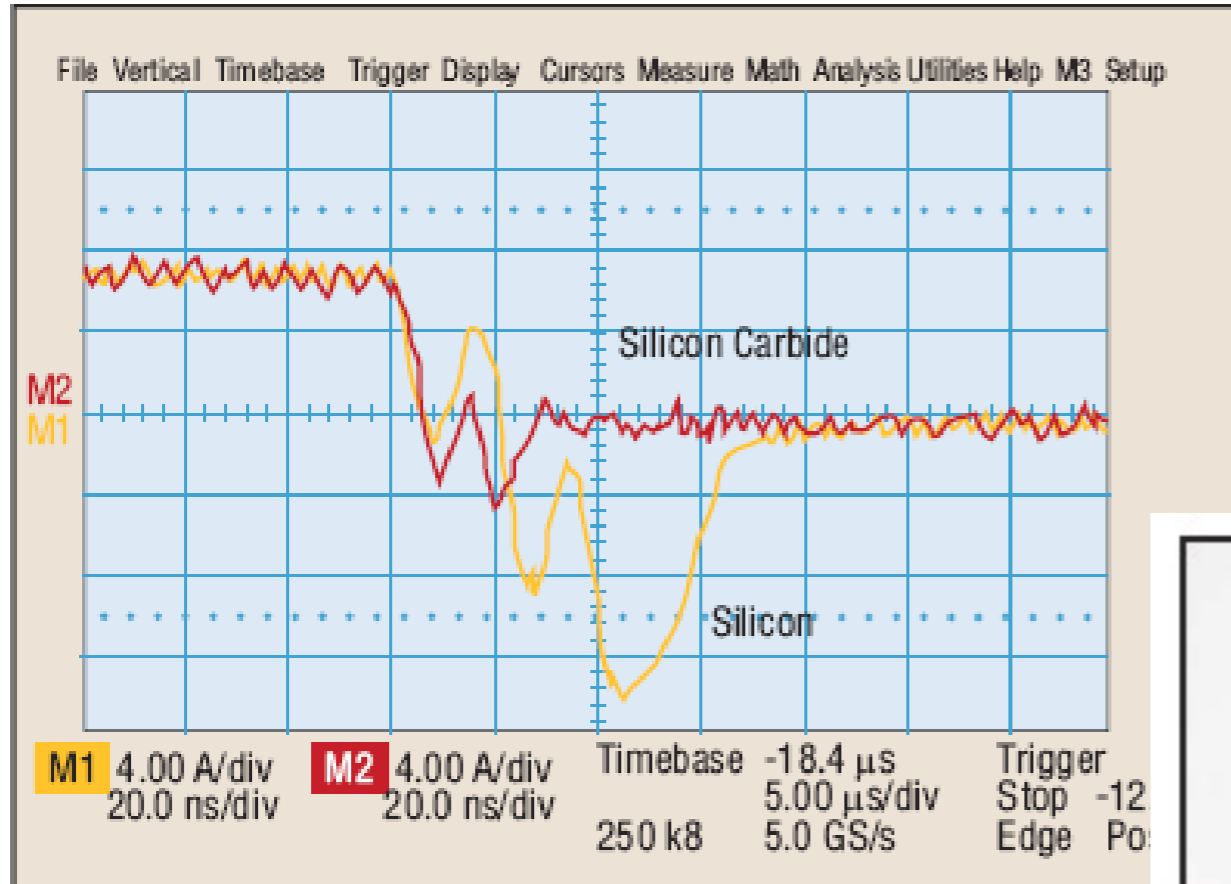

Fig. 4. Low-line diode recovery currents in PFC front-end converter

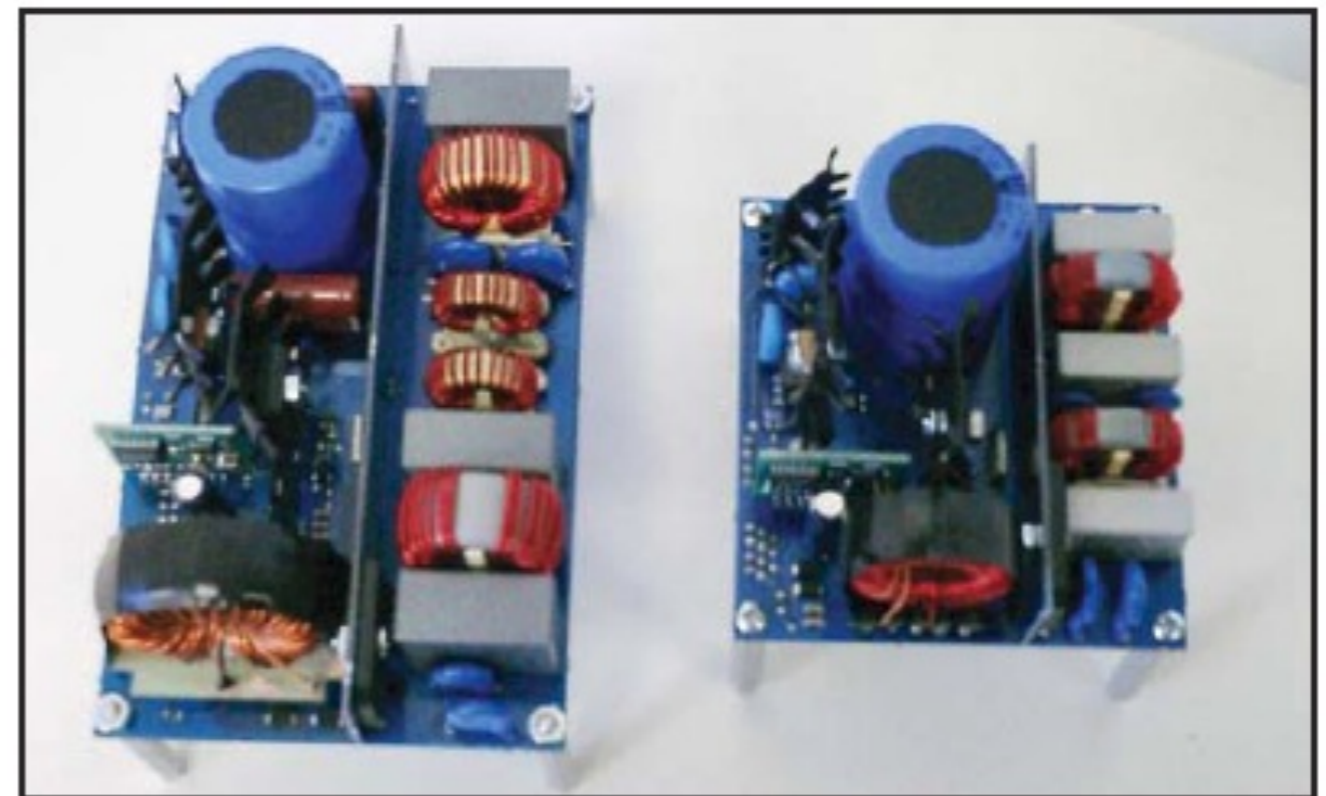

Fig. 8. A size comparison of an 80-kHz PFC front-end built with Si rectifiers (left) and a 200-kHz PFC front-end with SiC rectifiers.

# Perdas nos Diodos

## Classificação das perdas:

### 1. Condução;

$$P = V_{(TO)} \cdot I_{Dmed} + r_T \cdot I_{Def}^2$$

### 2. Comutação:

- Entrada em condução;

Por simulação

- Bloqueio.

Por simulação

# Características de Diodos Comerciais

## Principais características:

- Tensão de pico reversa;
- Queda de tensão direta;
- Corrente de pico;
- Corrente média;
- Corrente eficaz;
- Tempo de recuperação reversa.

## MURD320

### THERMAL CHARACTERISTICS

Rating	Symbol	Value	Unit
Thermal Resistance – Junction-to-Case	$R_{\theta JC}$	6	$^{\circ}C/W$
Thermal Resistance – Junction-to-Ambient (Note 1)	$R_{\theta JA}$	80	$^{\circ}C/W$

### ELECTRICAL CHARACTERISTICS

Maximum Instantaneous Forward Voltage Drop (Note 2) ( $i_F = 3$ Amps, $T_J = 25^{\circ}C$ ) ( $i_F = 3$ Amps, $T_J = 125^{\circ}C$ )	$V_F$	0.95 0.75	Volts
Maximum Instantaneous Reverse Current (Note 2) ( $T_J = 25^{\circ}C$ , Rated dc Voltage) ( $T_J = 125^{\circ}C$ , Rated dc Voltage)	$i_R$	5 500	$\mu A$
Maximum Reverse Recovery Time ( $I_F = 1$ Amp, $di/dt = 50$ Amps/ $\mu s$ , $V_R = 30$ V, $T_J = 25^{\circ}C$ ) ( $I_F = 0.5$ Amp, $i_R = 1$ Amp, $I_{REC} = 0.25$ A, $V_R = 30$ V, $T_J = 25^{\circ}C$ )	$t_{rr}$	35 25	ns

### MAXIMUM RATINGS

Rating	Symbol	Value	Unit
Peak Repetitive Reverse Voltage Working Peak Reverse Voltage DC Blocking Voltage	$V_{RRM}$ $V_{RWM}$ $V_R$	200	V
Average Rectified Forward Current (Rated $V_R$ , $T_C = 158^{\circ}C$ )	$I_{F(AV)}$	3.0	A
Peak Repetitive Forward Current (Rated $V_R$ , Square Wave, 20 kHz, $T_C = 158^{\circ}C$ )	$I_{FRM}$	6.0	A
Non-Repetitive Peak Surge Current (Surge Applied at Rated Load Conditions Halfwave, 60 Hz)	$I_{FSM}$	75	A
Operating Junction and Storage Temperature Range	$T_J, T_{stg}$	-65 to +175	$^{\circ}C$

# Características de Diodos Comerciais

## Tipos de diodos:

1. Standard and fast recovery;
2. Ultrafast rectifiers;
3. Ultrasoft rectifiers;
4. Silicon carbide (zero recovery).

### Rectifiers (227)

Standard and Fast Recovery Rectifiers (55)

UltraFast Rectifiers (165)

UltraSoft Rectifiers (7)

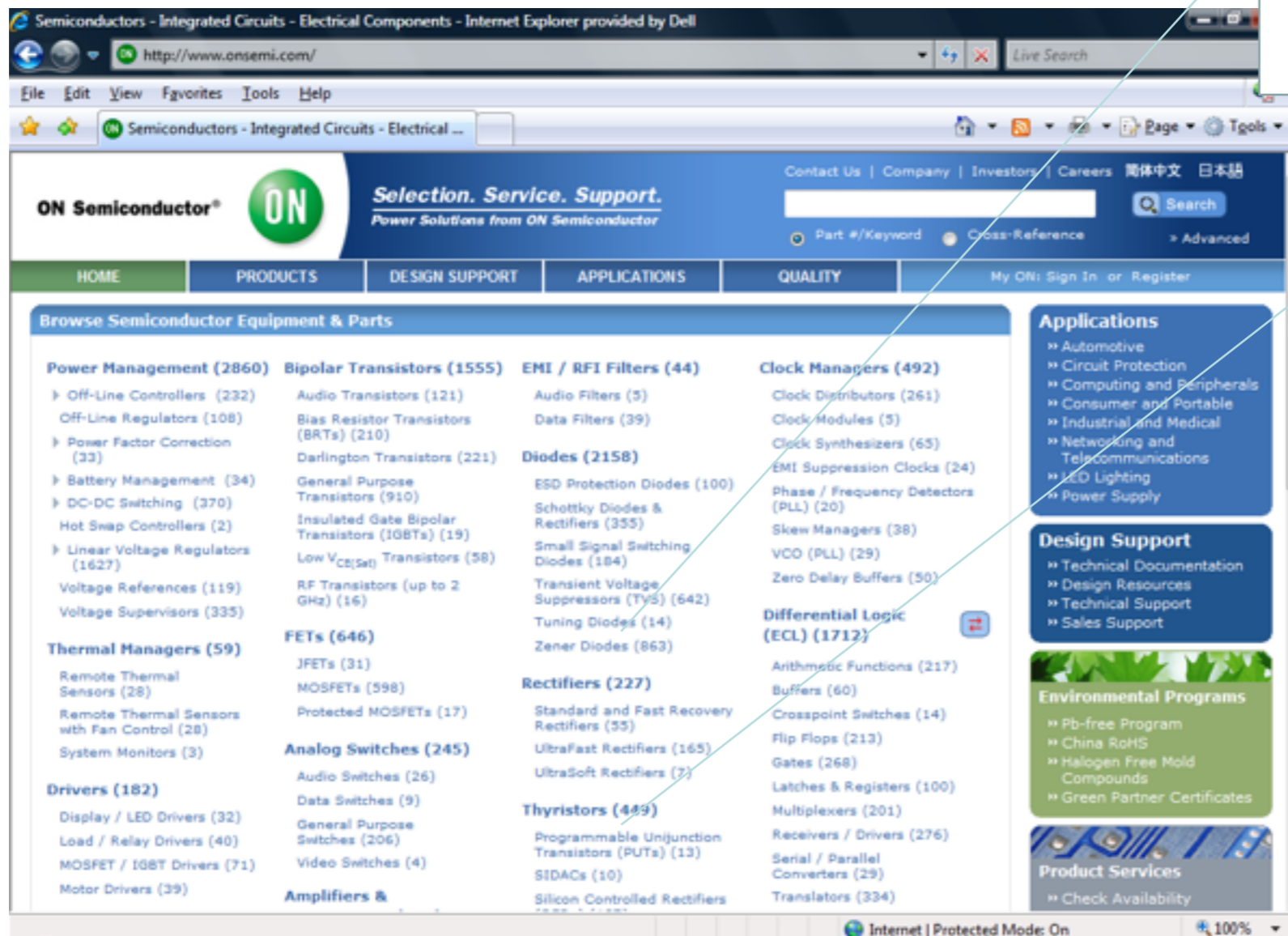

The screenshot shows the ON Semiconductor website with a grid of product categories. The 'Diodes' category is highlighted, and a callout box points to the 'Rectifiers (227)' sub-category. The website header includes the ON Semiconductor logo and navigation links. The main content area is titled 'Browse Semiconductor Equipment & Parts' and lists various product categories with their respective counts.

Category	Count
Power Management	2860
Bipolar Transistors	1555
EMI / RFI Filters	44
Clock Managers	492
Diodes	2158
Rectifiers	227
FETs	646
Analog Switches	245
Thyristors	449
Drivers	182
Amplifiers &	



# Características de Diodos Comerciais

## Demonstração

### Demo

- Testes de diodos com multímetro.



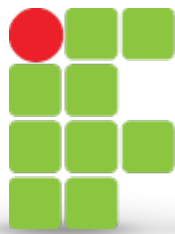

# Tiristores

## COUPLER SCHEMATIC

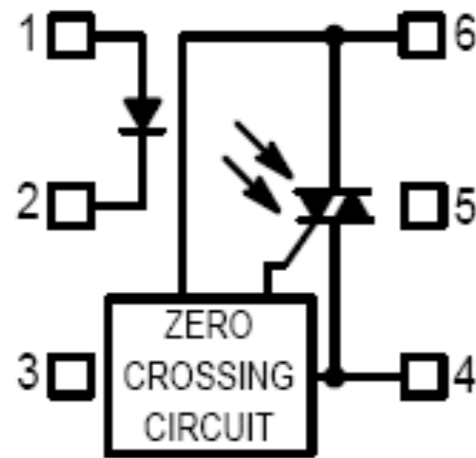

1. ANODE
2. CATHODE
3. NC
4. MAIN TERMINAL
5. SUBSTRATE  
DO NOT CONNECT
6. MAIN TERMINAL

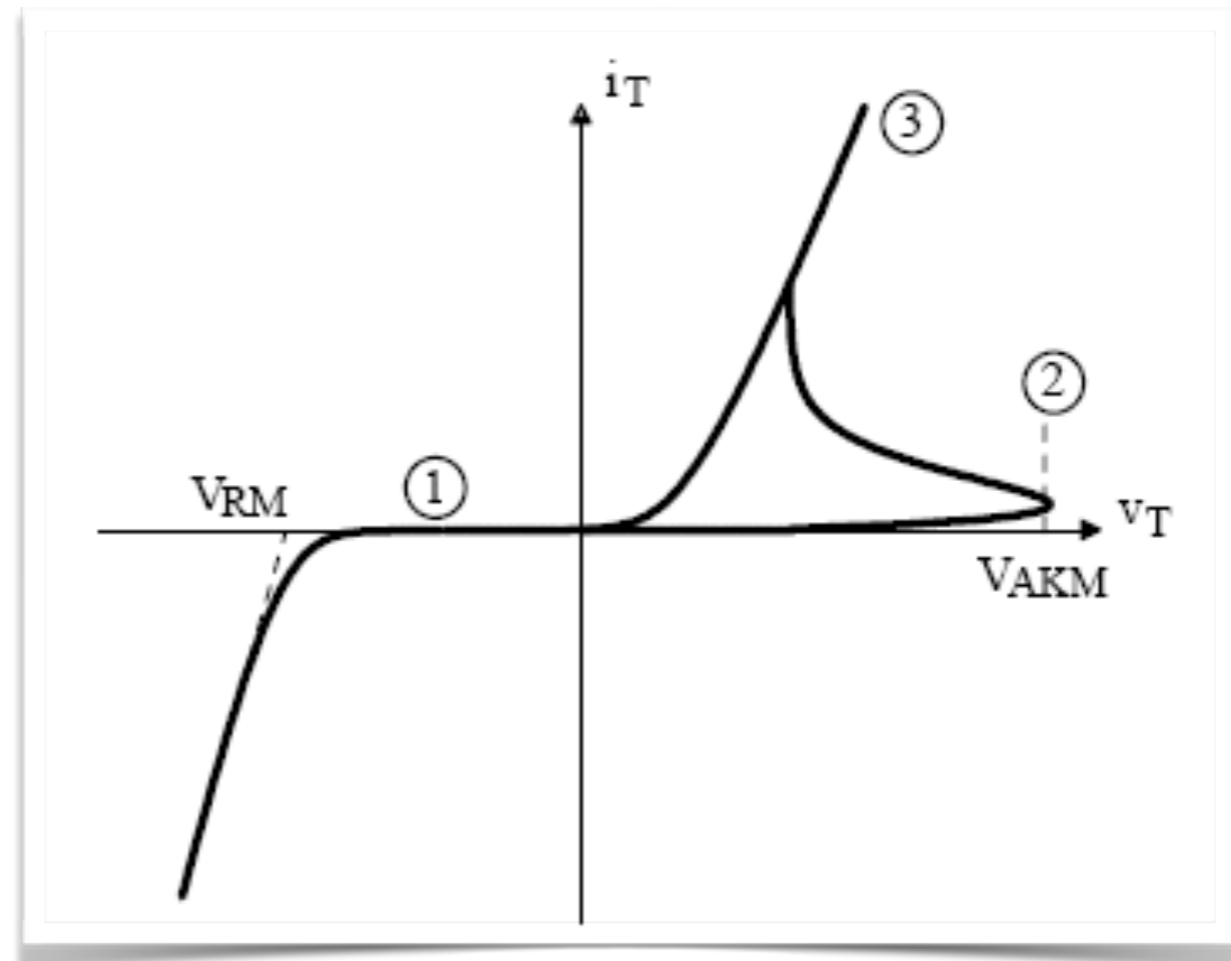

# Tiristor Ideal e Tiristor Real

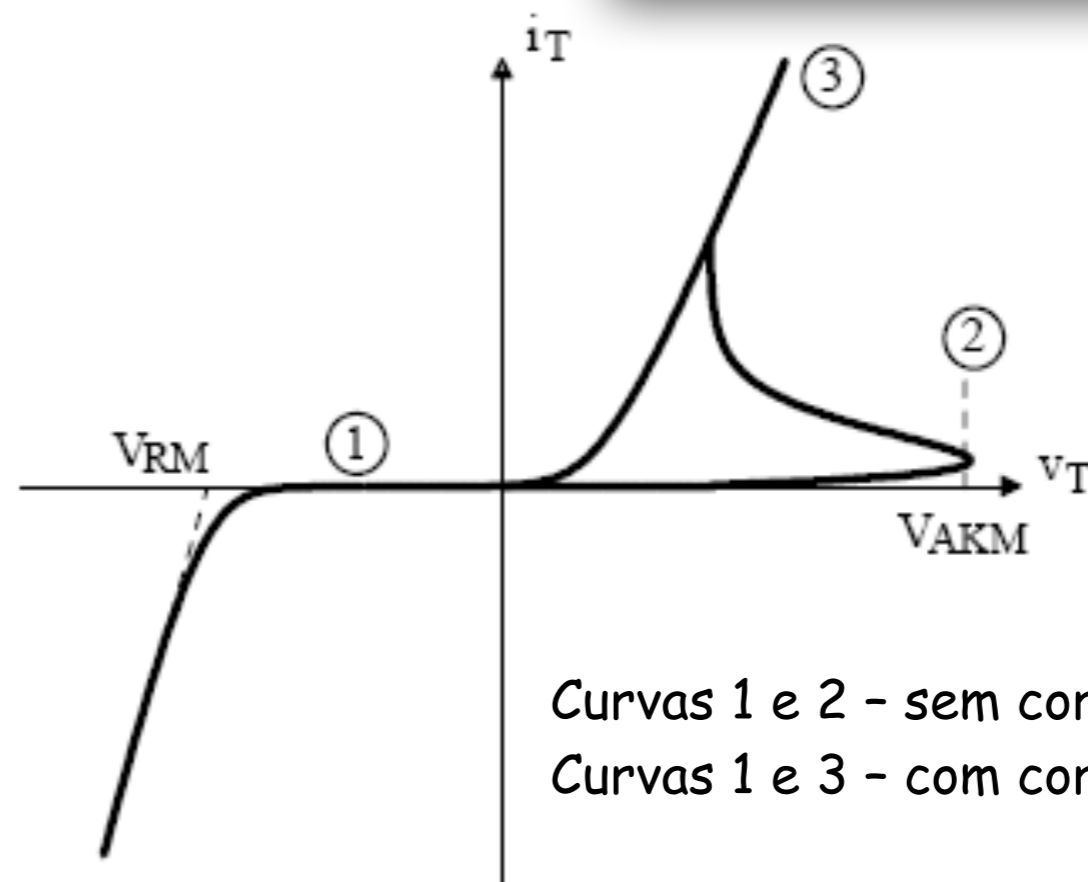
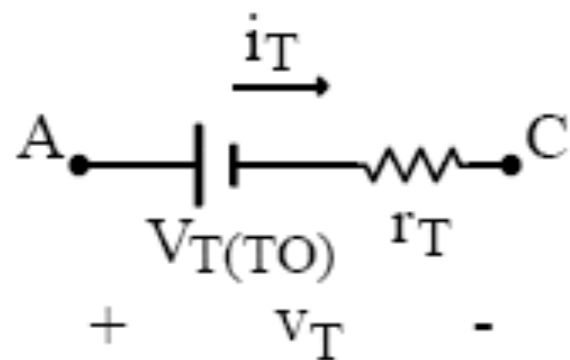
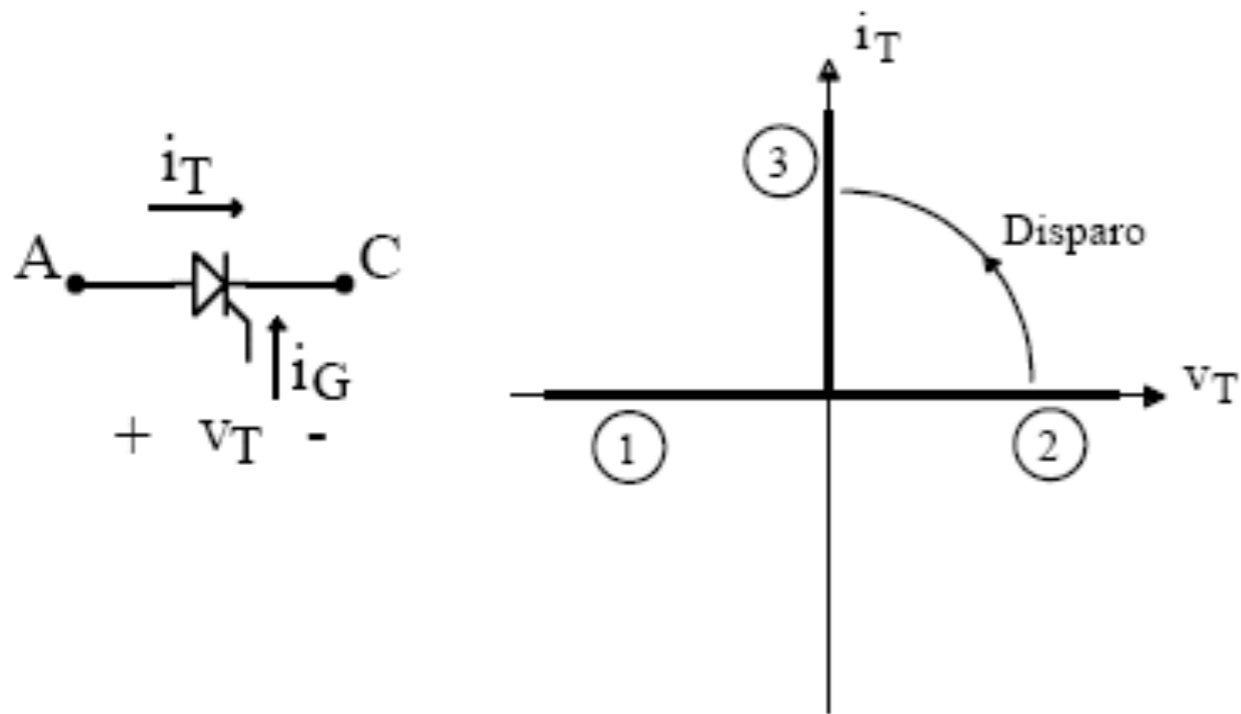

Curvas 1 e 2 - sem corrente de gatilho  
Curvas 1 e 3 - com corrente de gatilho

Característica estática

# Funcionamento do Tiristor

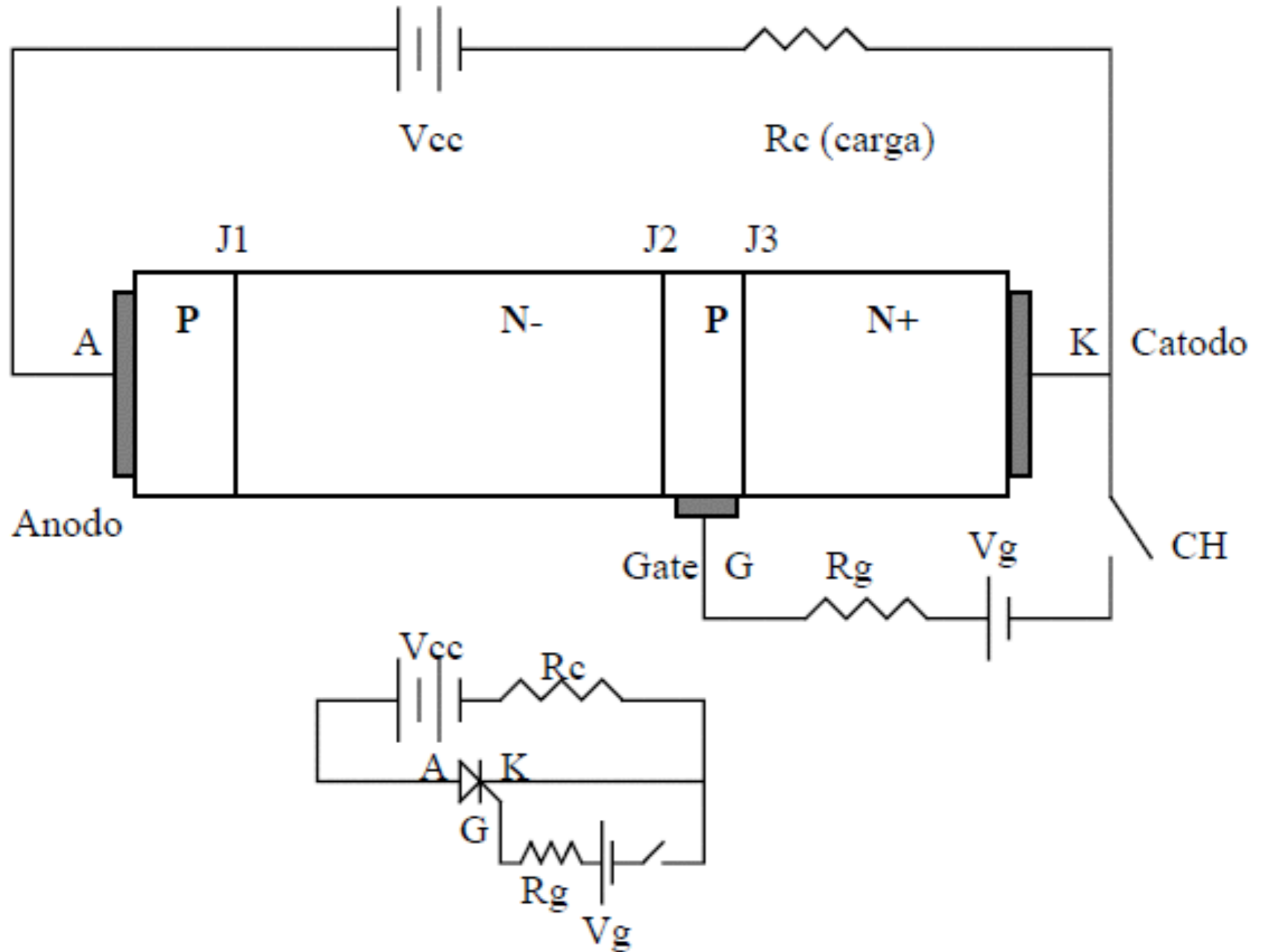

# Funcionamento do Tiristor

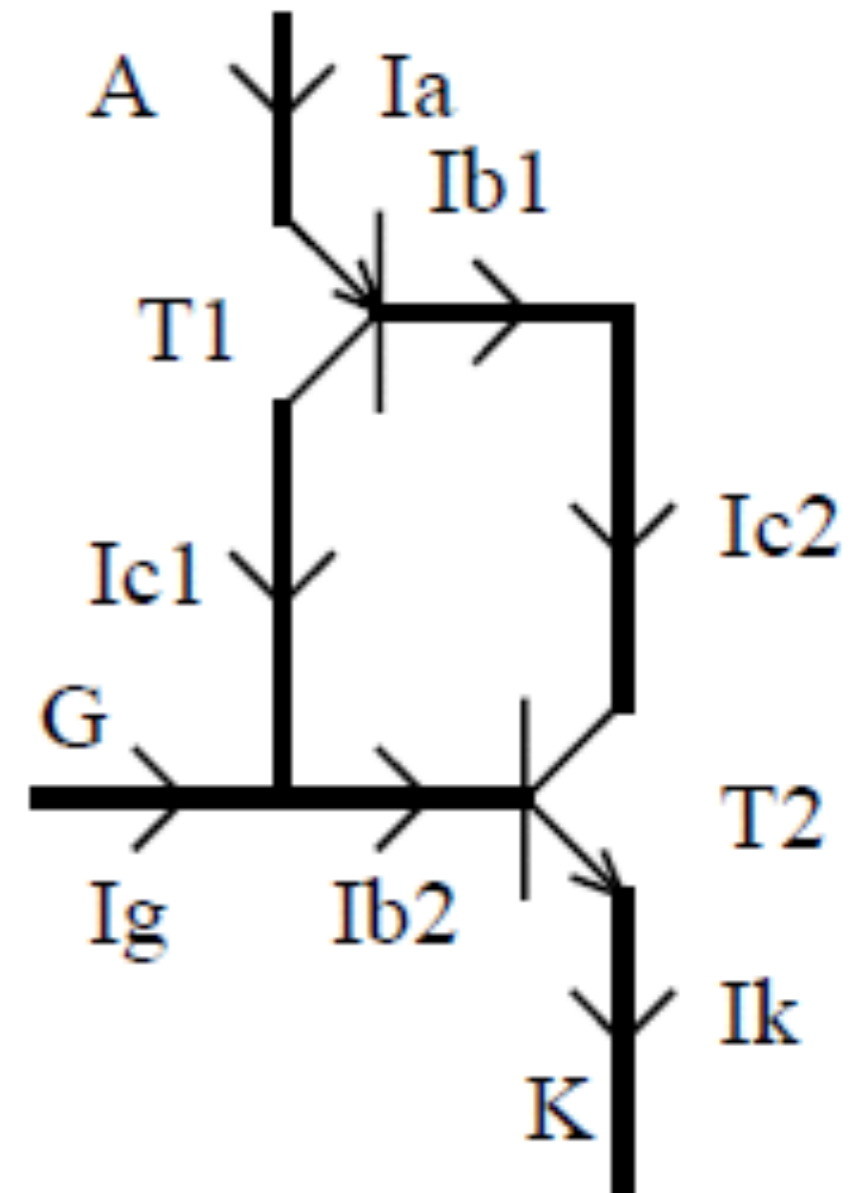
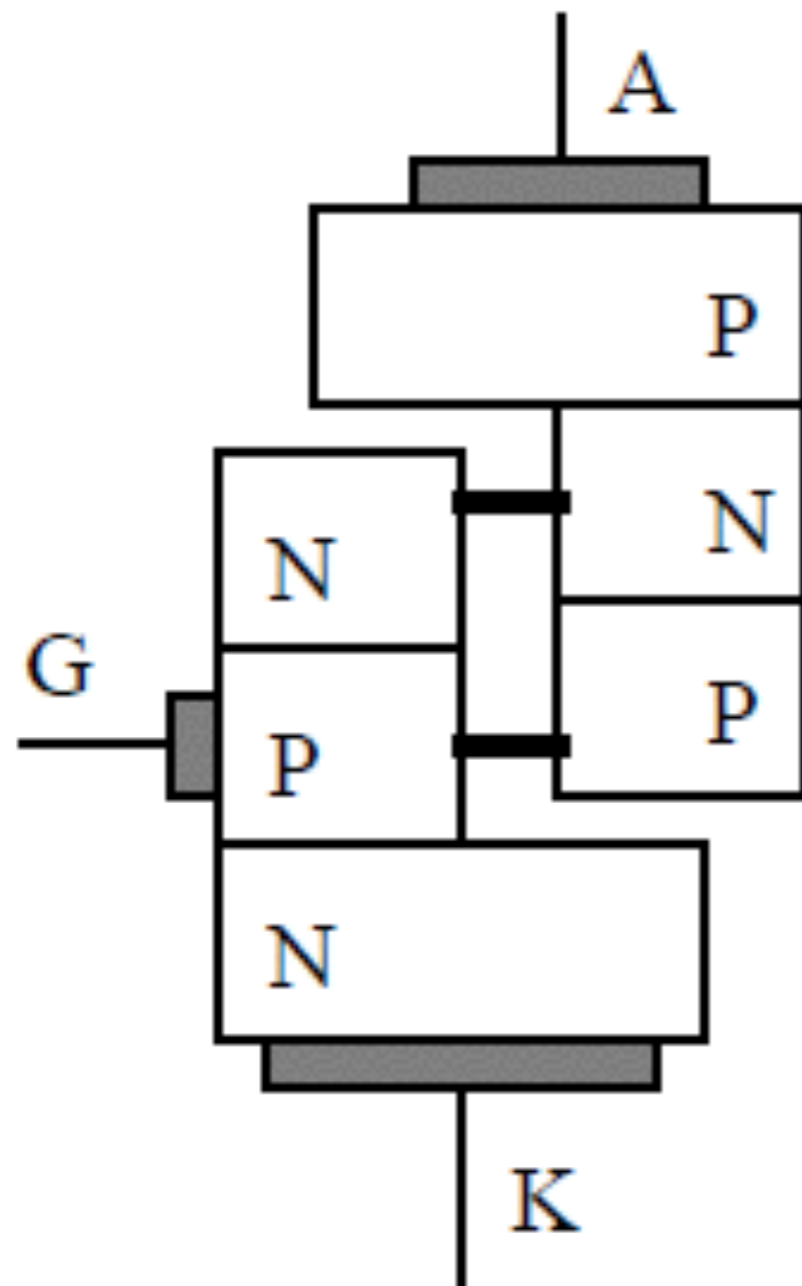

Estrutura interna e analogia com BJT

# Funcionamento do Tiristor

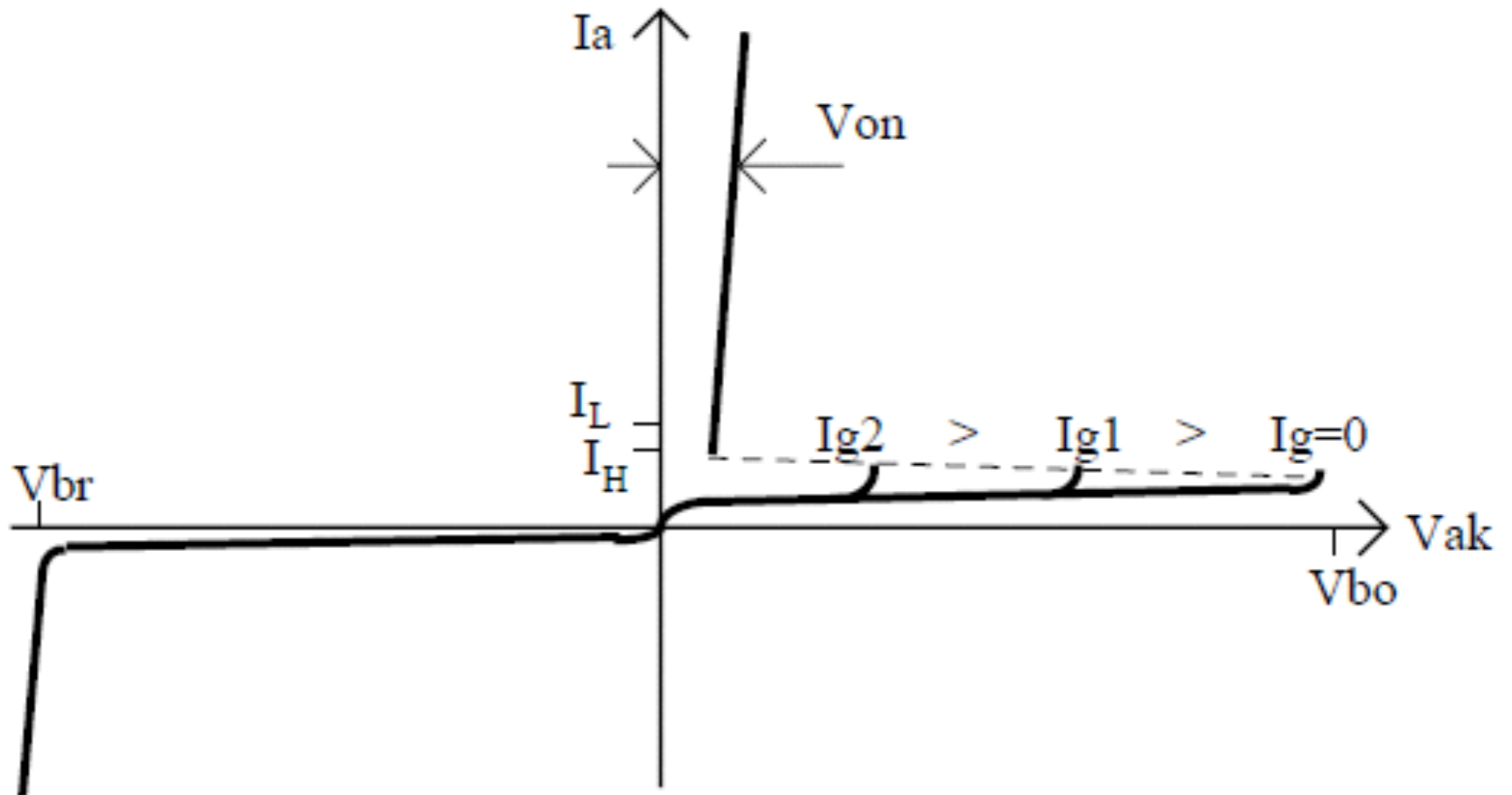

Curva característica  $V \times I$

# Funcionamento do Tiristor

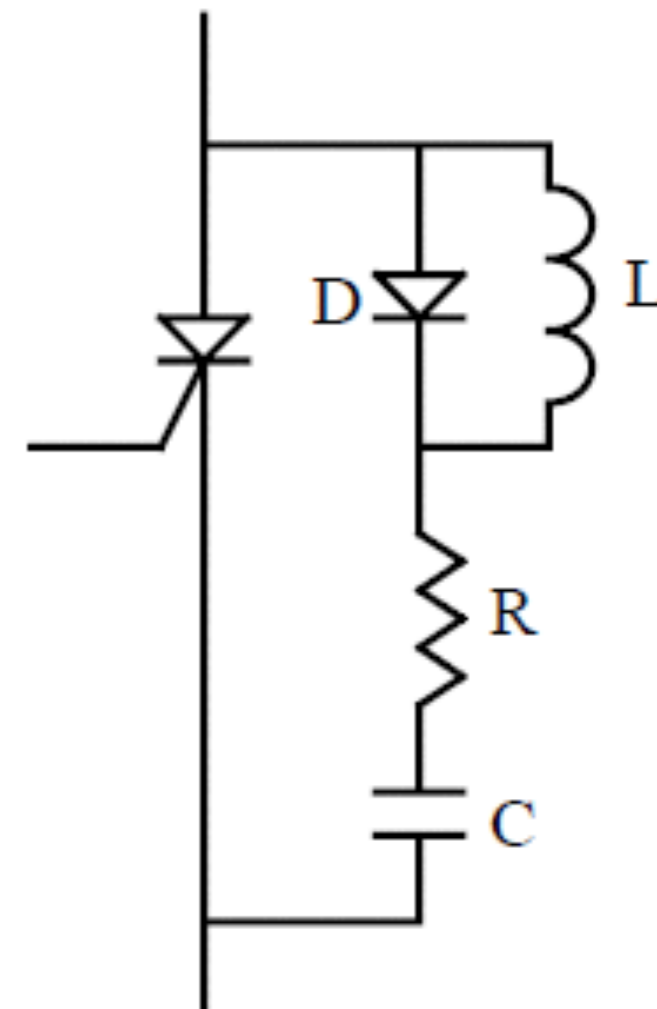
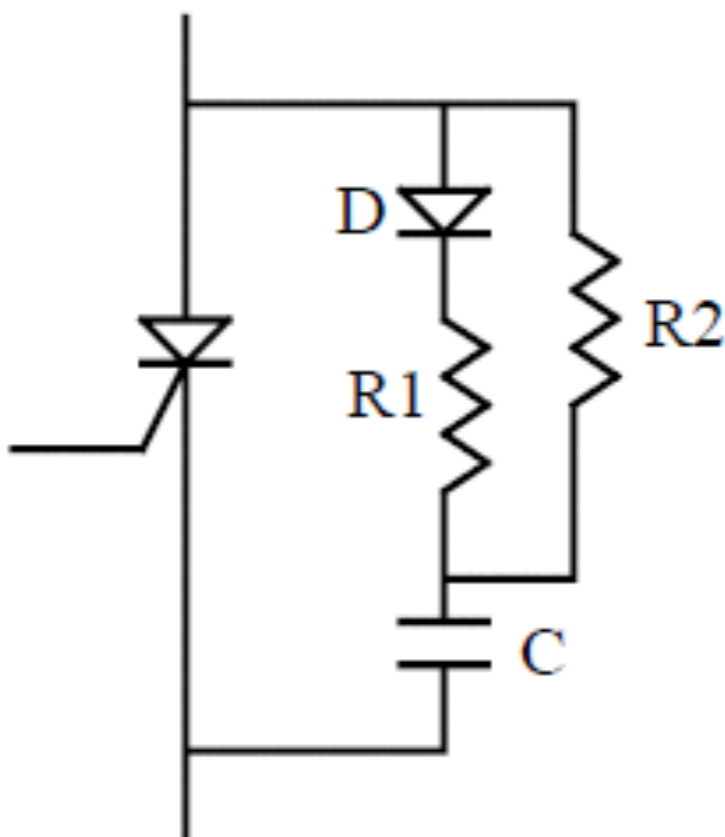
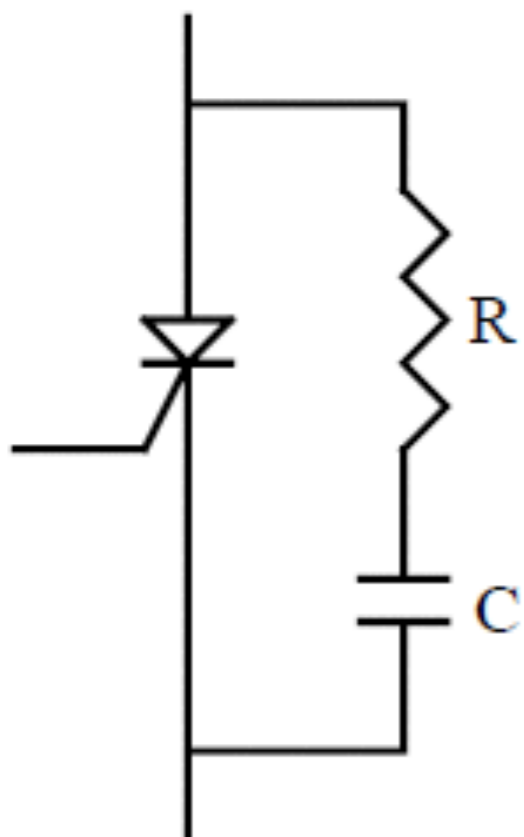

Circuitos para auxiliar na proteção de tiristores e evitar disparos intempestivos

# Funcionamento do Tiristor

## Demonstração

### Demo

- Curva de tiristores:
  - Sem corrente de gatilho;
  - Com corrente de gatilho.

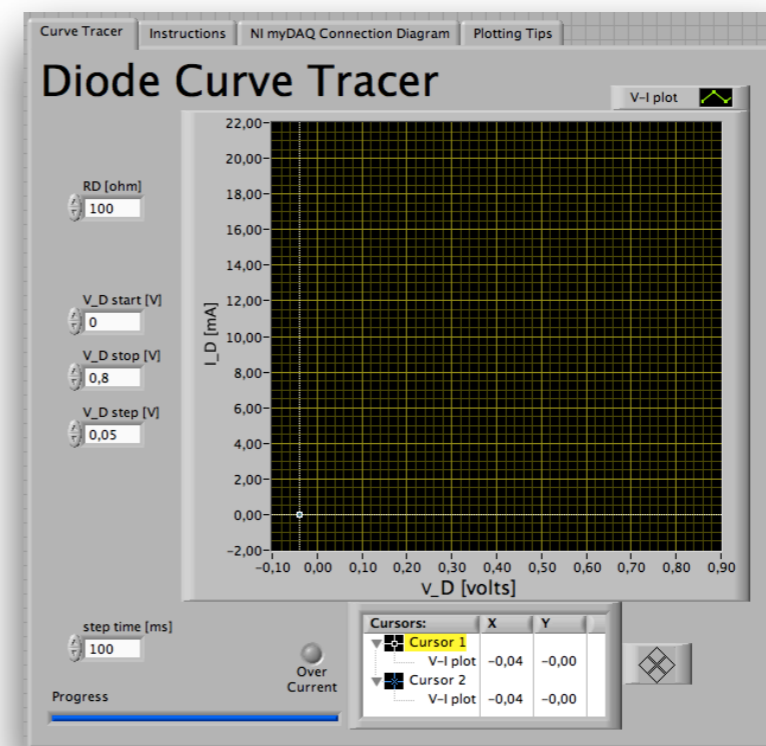

# Comutação de Tiristores

Disparo:

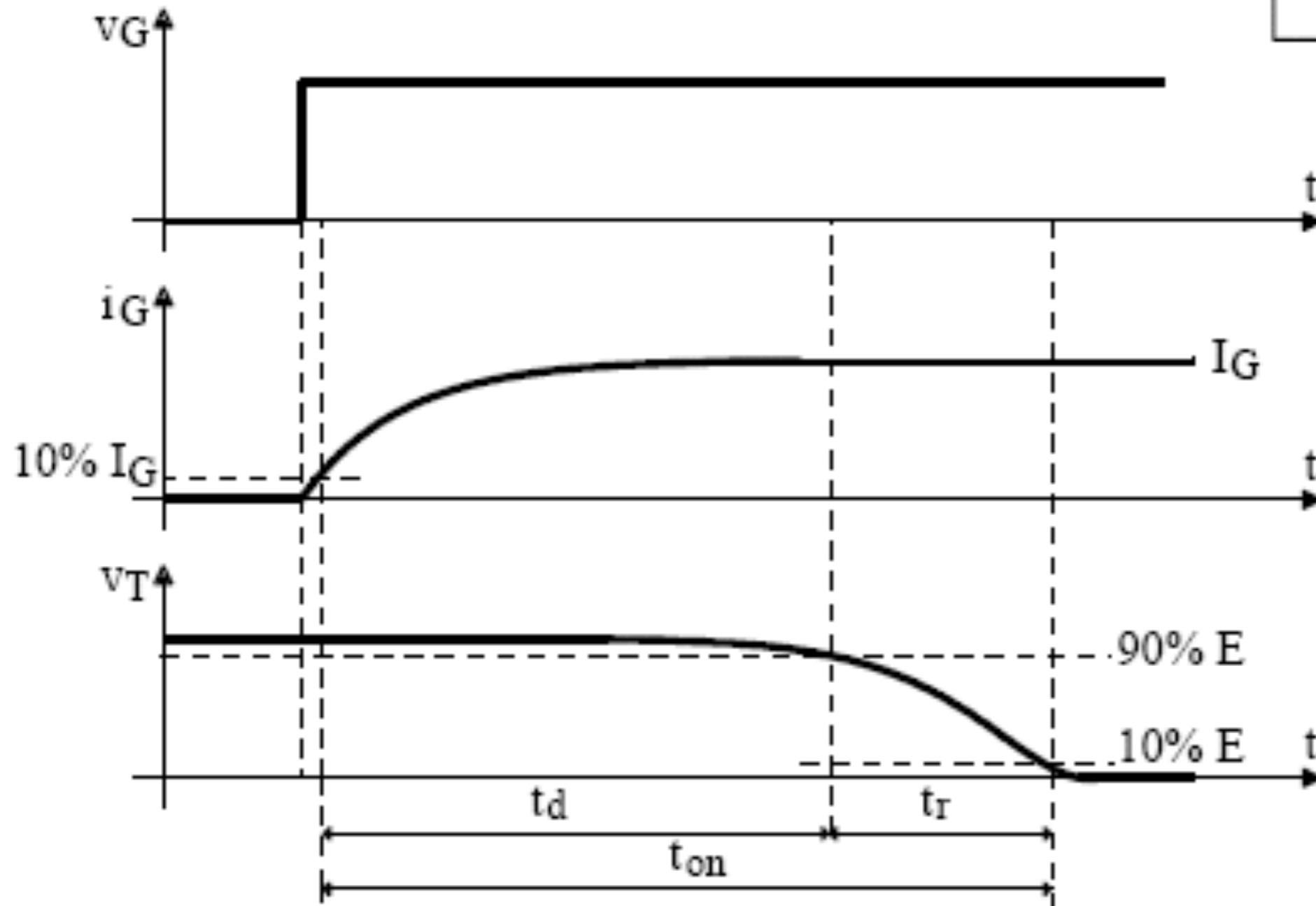
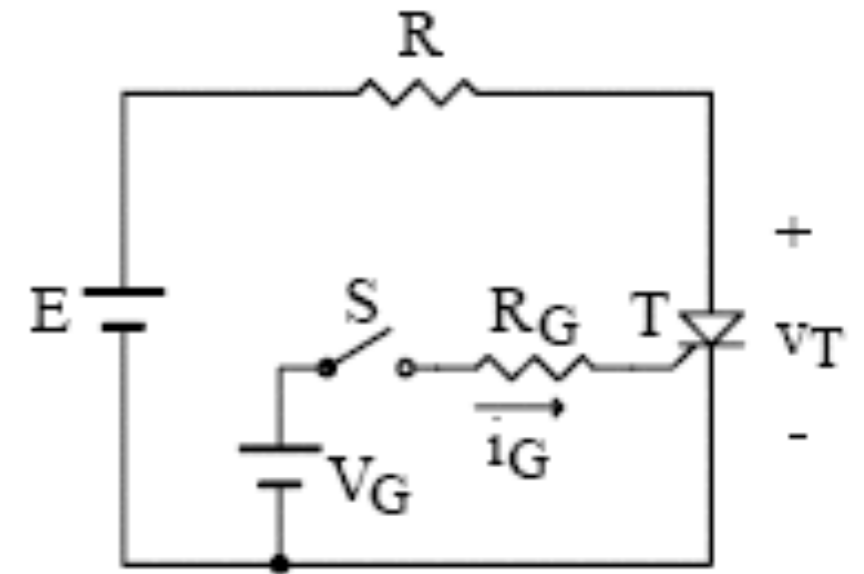

# Comutação de Tiristores

## Disparo:

- $t_{on}$  - tempo de fechamento;
- $t_d$  - tempo de retardo;
- $t_r$  - tempo de descida da tensão anodo-catodo.

$$t_{on} = t_d + t_r$$

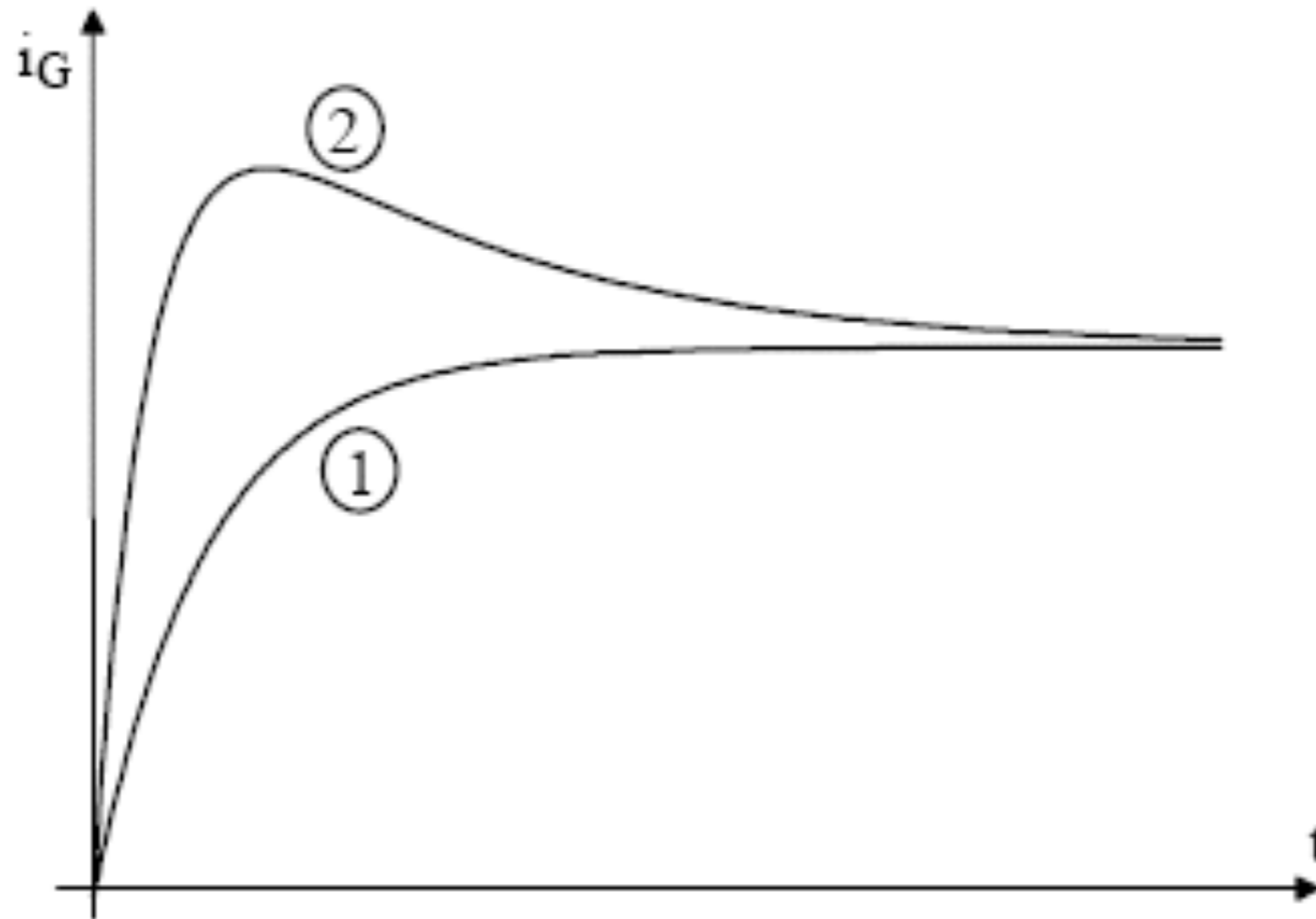

Influência da corrente de gatilho no tempo de retardo

# Comutação de Tiristores

Bloqueio:

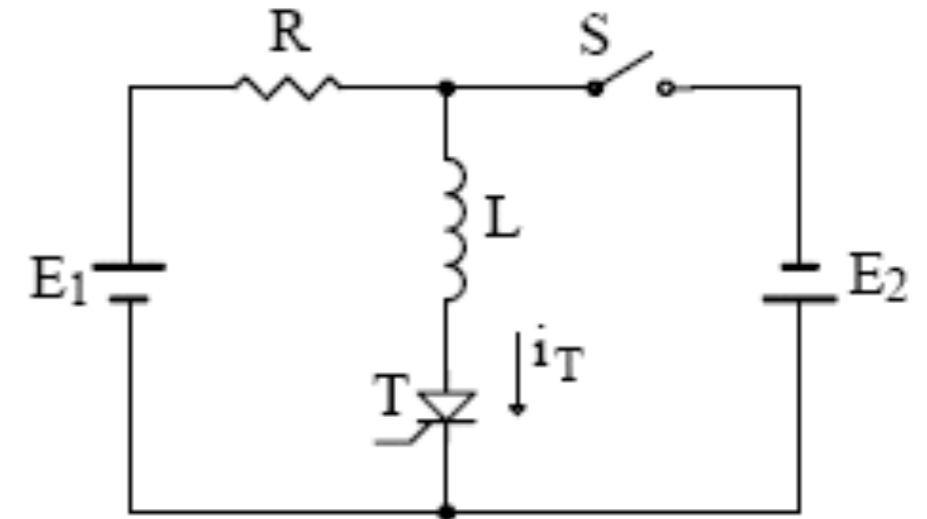
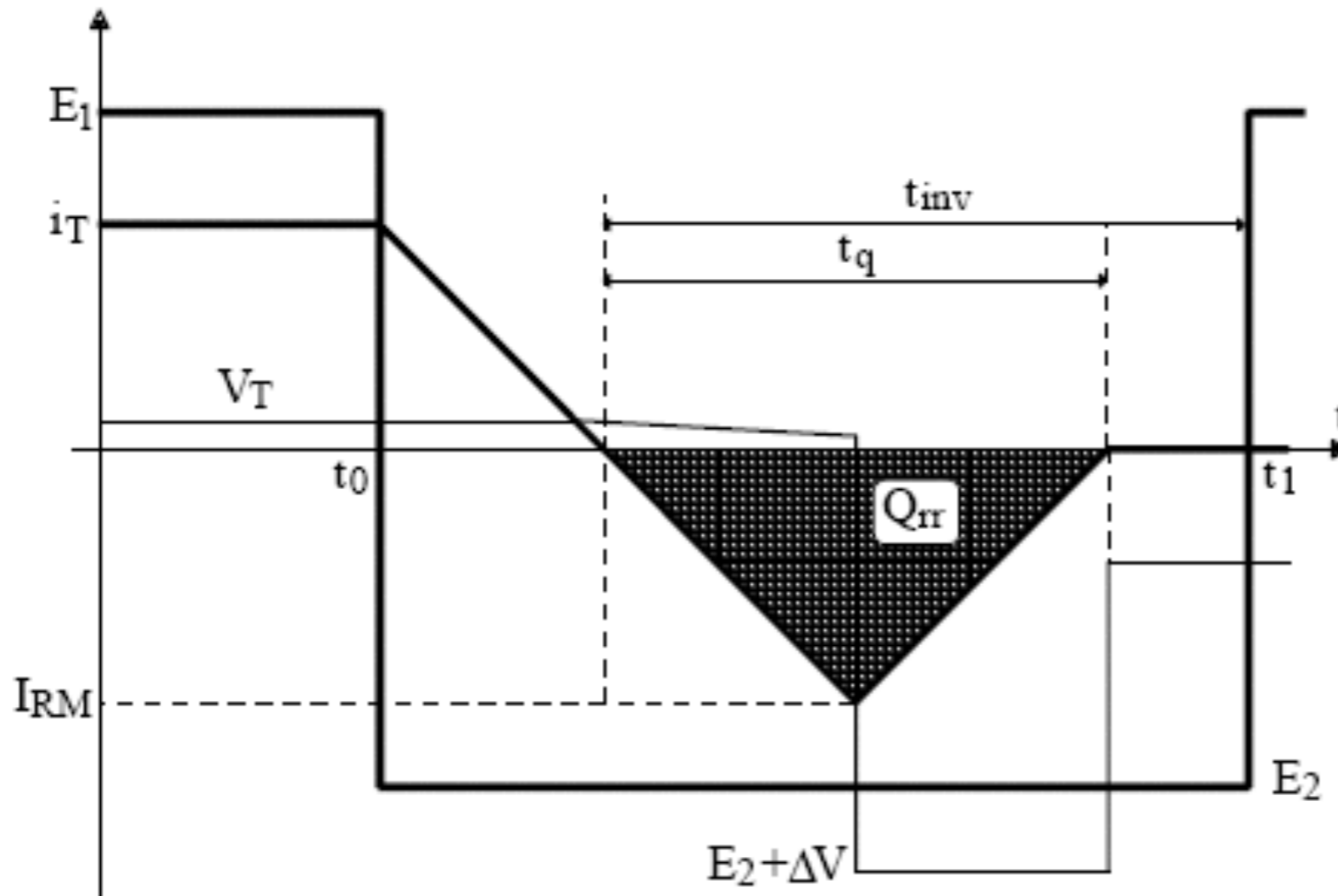

- $t_q$  - tempo de aplicação da tensão reversa para bloquear o tiristor;
- Para tiristores rápidos é da ordem de  $10 \mu s$  à  $200 \mu s$ .

# Perdas nos Tiristores

## Classificação das perdas:

### 1. Condução;

$$P = V_{(TO)} \cdot I_{Tmed} + r_T \cdot I_{Tef}^2$$

### 2. Comutação:

- Entrada em condução;

Por simulação

- Bloqueio.

Por simulação

# Características de Tiristores Comerciais

## Principais características:

1. Tensão de pico reversa;
2. Queda de tensão direta;
3. Corrente de pico;
4. Corrente média;
5. Corrente eficaz;
6. Tempo de recuperação reversa.

# Características de Tiristores Comerciais

## Tipos de tiristores de potência:

1. SCR;
2. Triac;
3. Sidac;
4. Para proteção, etc.

## Thyristors (449)

- Programmable Unijunction Transistors (PUTs) (13)
- SIDACs (10)
- Silicon Controlled Rectifiers (SCRs) (187)
- Thyristor Surge Protection Devices (TSPDs) (66)
- Triacs (173)

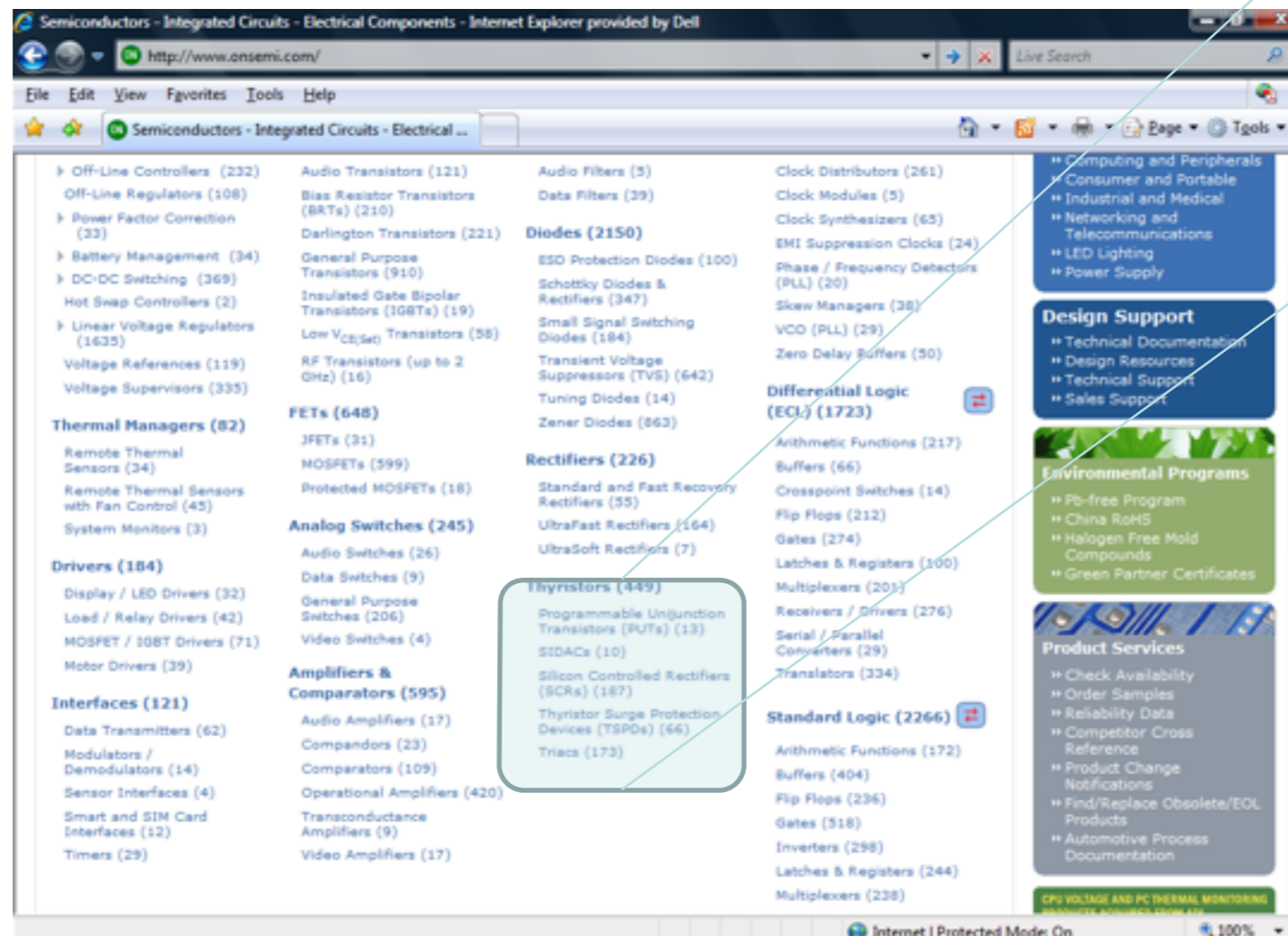

## MCR12DCM, MCR12DCN

Preferred Device

## Silicon Controlled Rectifiers

### Reverse Blocking Thyristors

Designed for high volume, low cost, industrial and consumer applications such as motor control; process control; temperature, light and speed control.

#### Features

- Small Size
- Passivated Die for Reliability and Uniformity
- Low Level Triggering and Holding Characteristics
- Epoxy Meets UL 94 V-0 @ 0.125 in
- ESD Ratings: Human Body Model, 3B > 8000 V  
Machine Model, C > 400 V
- Pb-Free Packages are Available



**ON Semiconductor®**

<http://onsemi.com>

---

**SCRs**  
**12 AMPERES RMS**  
**600 – 800 VOLTS**

---



# Características de Tiristores Comerciais

## 2N6344A, 2N6348A, 2N6349A

Preferred Device

### Triacs

#### Silicon Bidirectional Thyristors

Designed primarily for full-wave AC control applications, such as light dimmers, motor controls, heating controls and power supplies; or wherever full-wave silicon gate controlled solid-state devices are needed. Triac type thyristors switch from a blocking to a conducting state for either polarity of applied anode voltage with positive or negative gate triggering.

#### Features

- Blocking Voltage to 800 V
- All Diffused and Glass Passivated Junctions for Greater Parameter Uniformity and Stability
- Small, Rugged, Thermowatt Construction for Low Thermal Resistance, High Heat Dissipation and Durability
- Gate Triggering Guaranteed in all Four Quadrants
- For 400 Hz Operation, Consult Factory
- 8.0 A Devices Available as 2N6344 thru 2N6349
- Pb-Free Packages are Available\*



**ON Semiconductor®**

<http://onsemi.com>

**TRIACS**  
**12 AMPERES RMS**  
**600 thru 800 VOLTS**



#### MARKING DIAGRAM

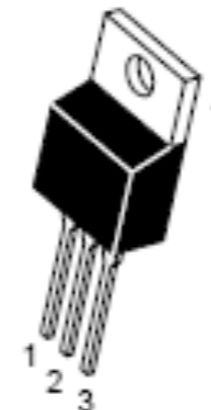

TO-220AB  
CASE 221A  
STYLE 4

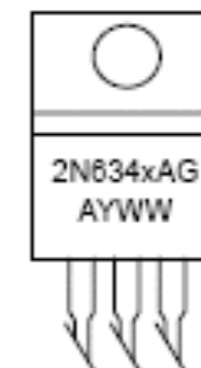



# Acionamento de Tiristores

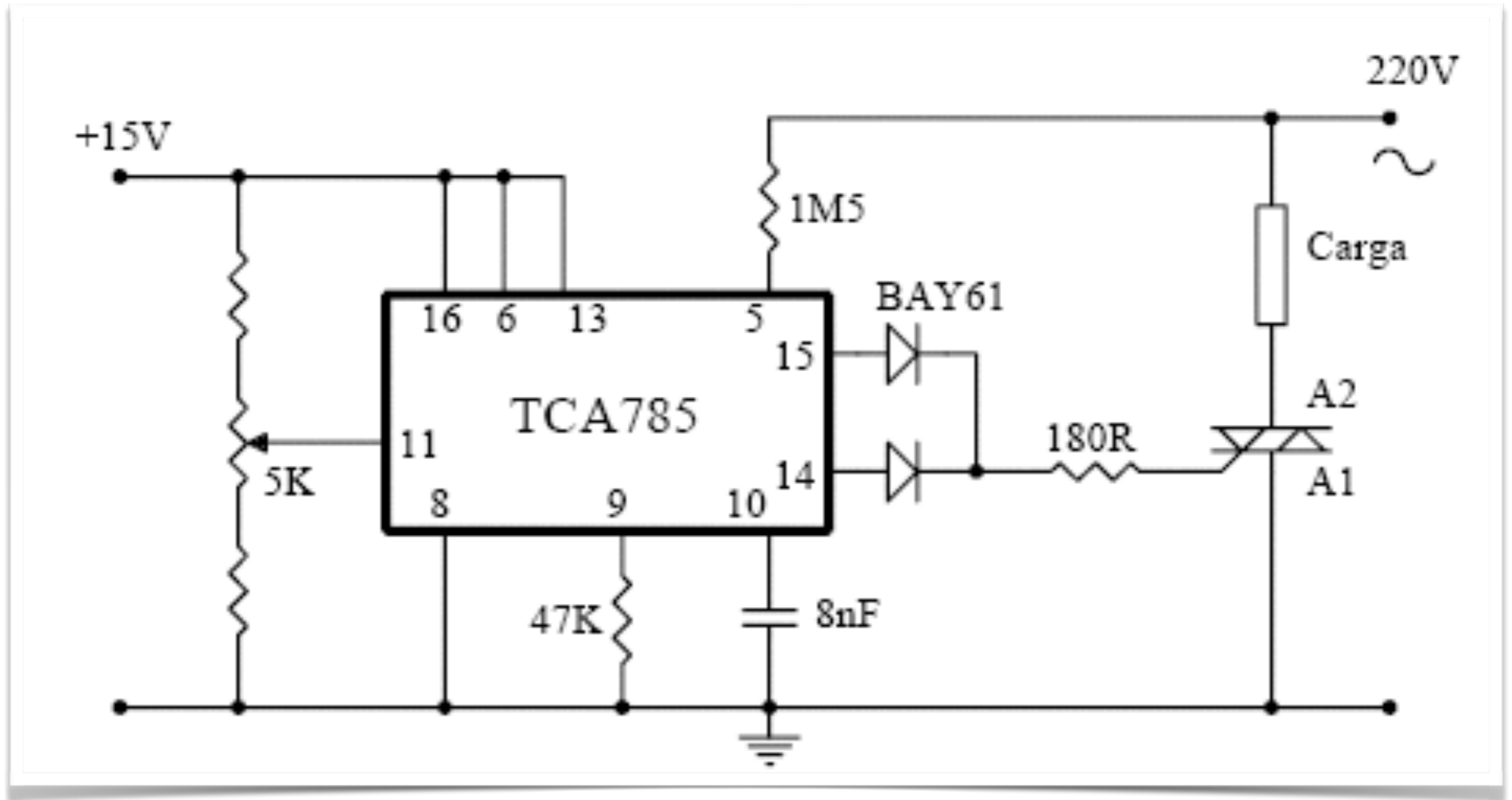

# Acionamento de Tiristores

**FAIRCHILD**  
SEMICONDUCTOR



## 6-Pin DIP Zero-Cross Optoisolators Triac Driver Output (600 Volts Peak)

The MOC3061, MOC3062 and MOC3063 devices consist of gallium arsenide infrared emitting diodes optically coupled to monolithic silicon detectors performing the functions of Zero Voltage Crossing bilateral triac drivers.

They are designed for use with a triac in the interface of logic systems to equipment powered from 115/240 Vac lines, such as solid-state relays, industrial controls, motors, solenoids and consumer appliances, etc.

- Simplifies Logic Control of 115/240 Vac Power
- Zero Voltage Crossing
- dV/dt of 1500 V/μs Typical, 600 V/μs Guaranteed
- To order devices that are tested and marked per VDE 0884 requirements, the suffix "V" must be included at end of part number. VDE 0884 is a test option.

Recommended for 115/240 Vac(rms) Applications:

- Solenoid/Valve Controls
- Lighting Controls
- Static Power Switches
- AC Motor Drives
- Temperature Controls
- E.M. Contactors
- AC Motor Starters
- Solid State Relays

### MAXIMUM RATINGS

Rating	Symbol	Value	Unit
--------	--------	-------	------

### INFRARED EMITTING DIODE

Reverse Voltage	$V_{RR}$	6	Volts
Forward Current — Continuous	$I_F$	80	mA
Total Power Dissipation @ $T_A = 25^\circ\text{C}$ Negligible Power in Output Driver Derate above $25^\circ\text{C}$	$P_D$	120	mW
		1.41	mW/°C

### OUTPUT DRIVER

Off-State Output Terminal Voltage	$V_{ORM}$	600	Volts
Peak Repetitive Surge Current (PW = 100 μs, 120 pps)	$I_{TSM}$	1	A
Total Power Dissipation @ $T_A = 25^\circ\text{C}$ Derate above $25^\circ\text{C}$	$P_D$	150	mW
		1.78	mW/°C

### TOTAL DEVICE

Isolation Surge Voltage(1) (Peak ac Voltage, 60 Hz, 1 Second Duration)	$V_{ISO}$	7500	Vac(pk)
Total Power Dissipation @ $T_A = 25^\circ\text{C}$ Derate above $25^\circ\text{C}$	$P_D$	250	mW
		2.94	mW/°C
Junction Temperature Range	$T_J$	-40 to +100	°C
Ambient Operating Temperature Range	$T_A$	-40 to +85	°C
Storage Temperature Range	$T_{stg}$	-40 to +150	°C
Soldering Temperature (10 s)	$T_s$	260	°C

**MOC3061**  
**MOC3062**  
**MOC3063**



STANDARD THRU HOLE

### COUPLER SCHEMATIC

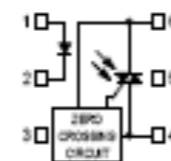

1. ANODE
2. CATHODE
3. NC
4. MAIN TERMINAL
5. SUBSTRATE  
DO NOT CONNECT
6. MAIN TERMINAL

## COUPLER SCHEMATIC

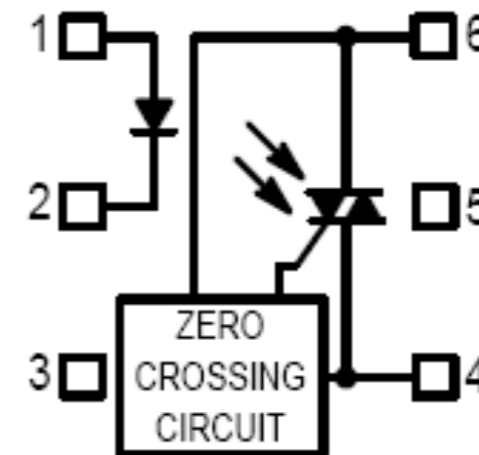

1. ANODE
2. CATHODE
3. NC
4. MAIN TERMINAL
5. SUBSTRATE  
DO NOT CONNECT
6. MAIN TERMINAL

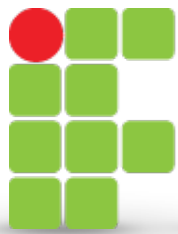

# Acionamento de Tiristores

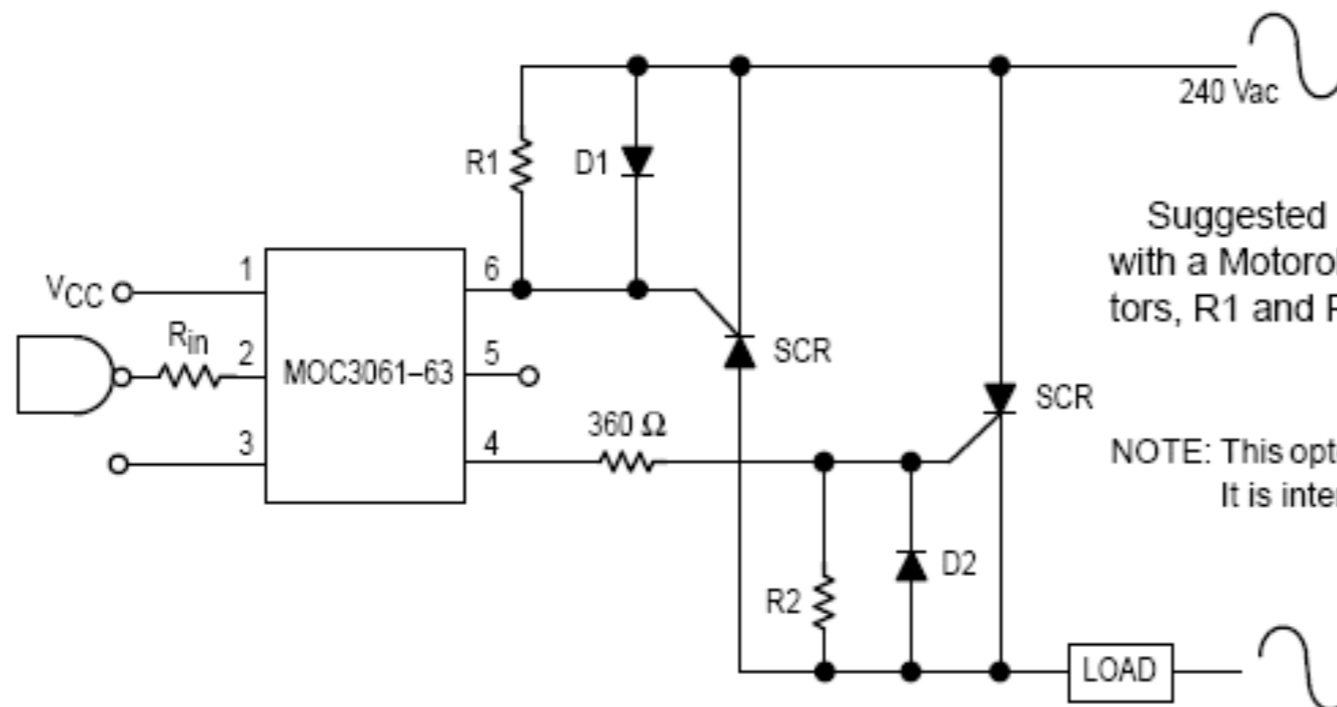
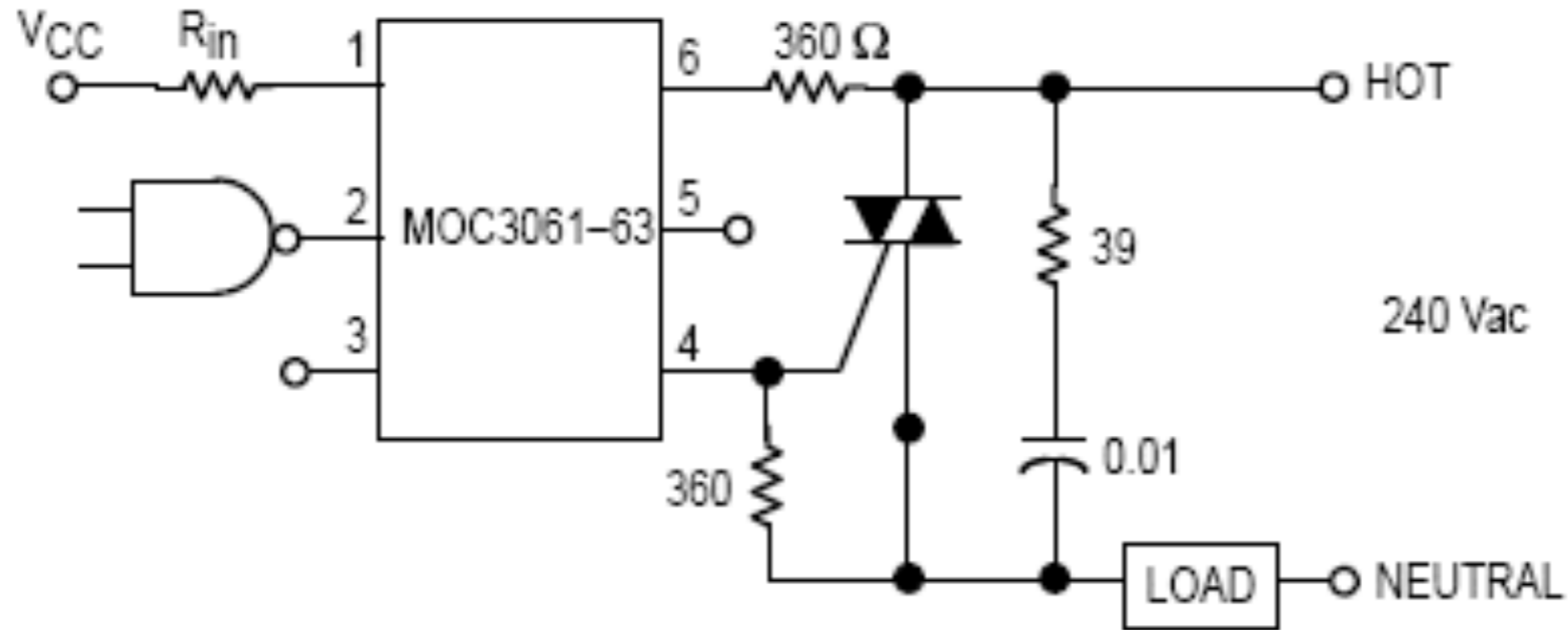

Suggested method of firing two, back-to-back SCR's, with a Motorola triac driver. Diodes can be 1N4001; resistors, R1 and R2, are optional 330 ohms.

NOTE: This optoisolator should not be used to drive a load directly. It is intended to be a trigger device only.

# Características de Diodos Comerciais

## Demonstração

### Demo

- Testes de tiristores com multímetro.

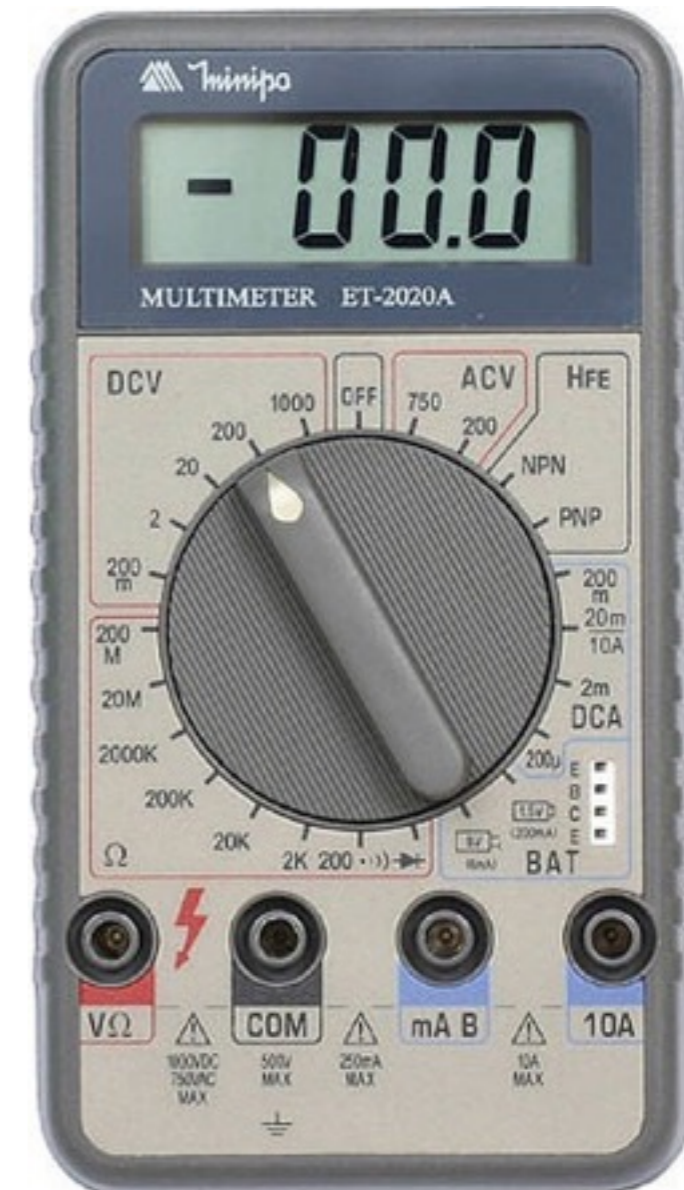

# Próxima Aula

## Componentes Semicondutores:

- BJT, MOSFET e IGBT.

