

Instituto Federal de Educação, Ciência e Tecnologia de Santa Catarina

Departamento Acadêmico de Eletrônica

Eletrônica de Potência



Semicondutores de Potência

BJT, MOSFET e IGBT

Prof. Clovis Antonio Petry.

Florianópolis, outubro de 2015.

Biografia para Esta Aula

Capítulos 3:

- Transistores de potência.



www.ProfessorPetry.com.br

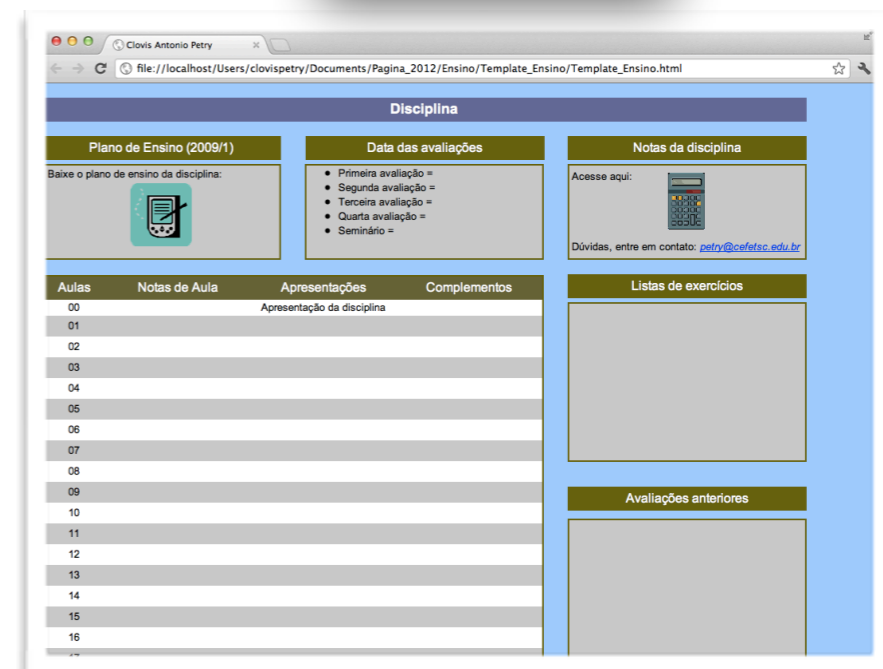

Disciplina

Plano de Ensino (2009/1)

Baixe o plano de ensino da disciplina:

Data das avaliações

- Primeira avaliação =
- Segunda avaliação =
- Terceira avaliação =
- Quarta avaliação =
- Seminário =

Notas da disciplina

Acesse aqui:

Dúvidas, entre em contato: petry@cefetsc.edu.br

Aulas	Notas de Aula	Apresentações	Complementos
00		Apresentação da disciplina	
01			
02			
03			
04			
05			
06			
07			
08			
09			
10			
11			
12			
13			
14			
15			
16			

Listas de exercícios

Avaliações anteriores

Semicondutores de potência:

- Semicondutores para eletrônica de potência;
- Revisão de BJT;
- BJT x FET;
- FETs;
- MOSFETs;
- IGBTs.

Semicondutores de Potência

Semicondutores aplicados à eletrônica de potência:

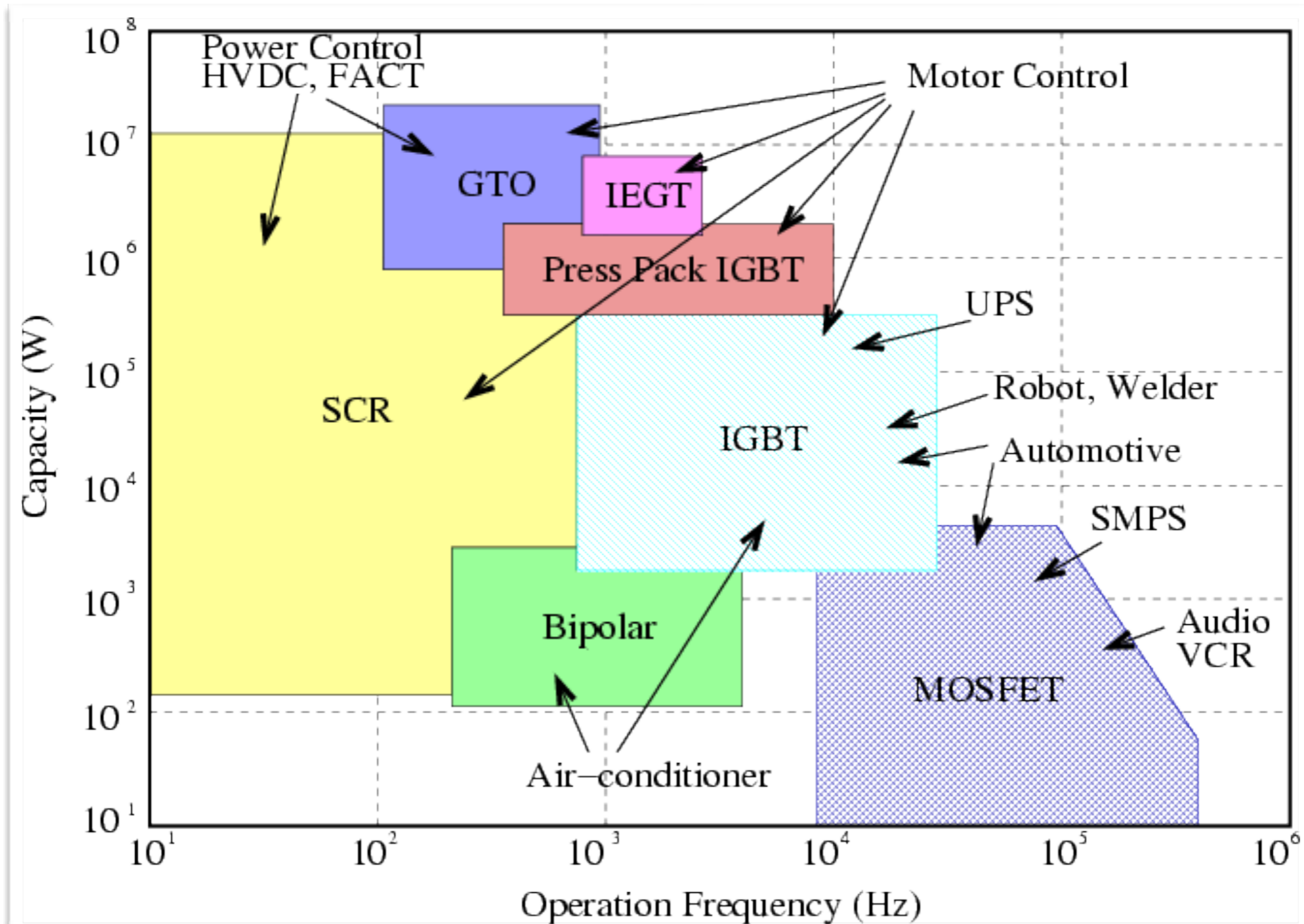

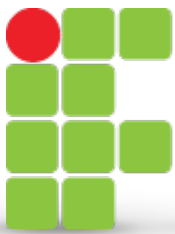

INSTITUTO FEDERAL
SANTA CATARINA

Semicondutores de Potência

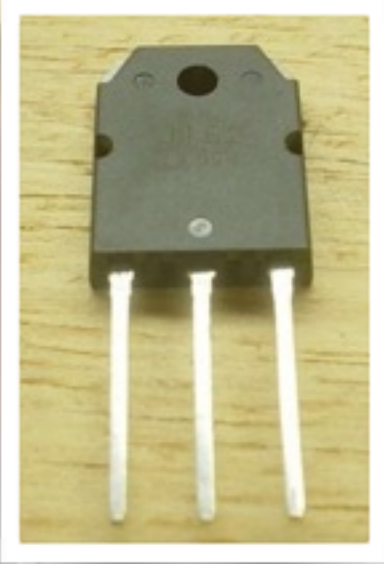

Revisão - BJT

BJT - Transistor bipolar de junção

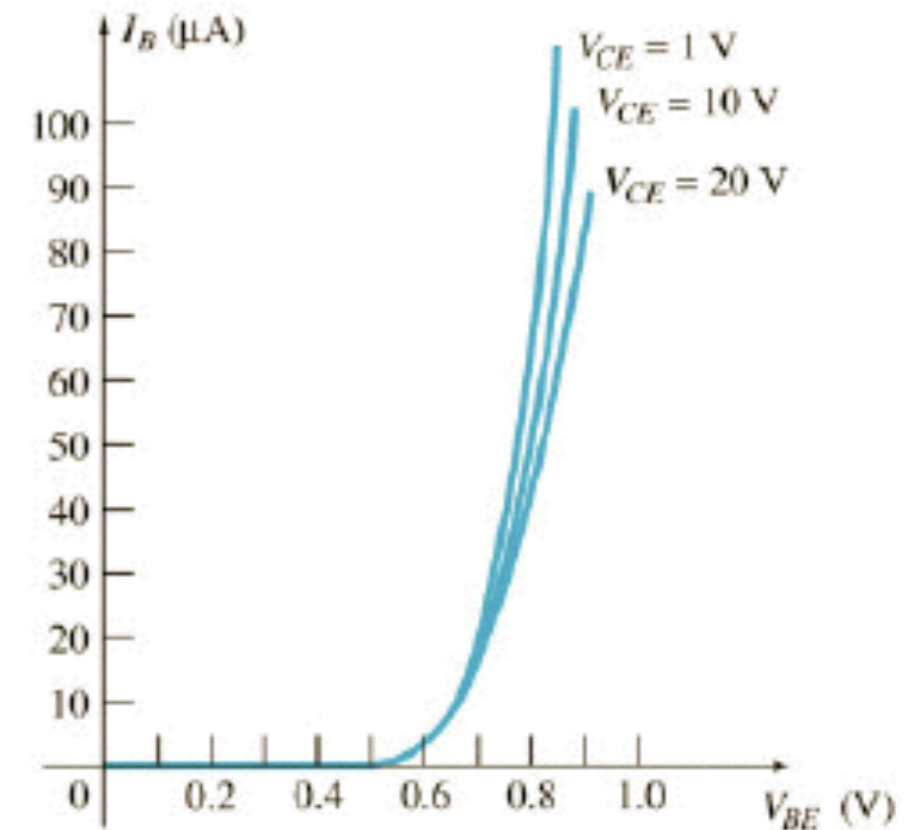
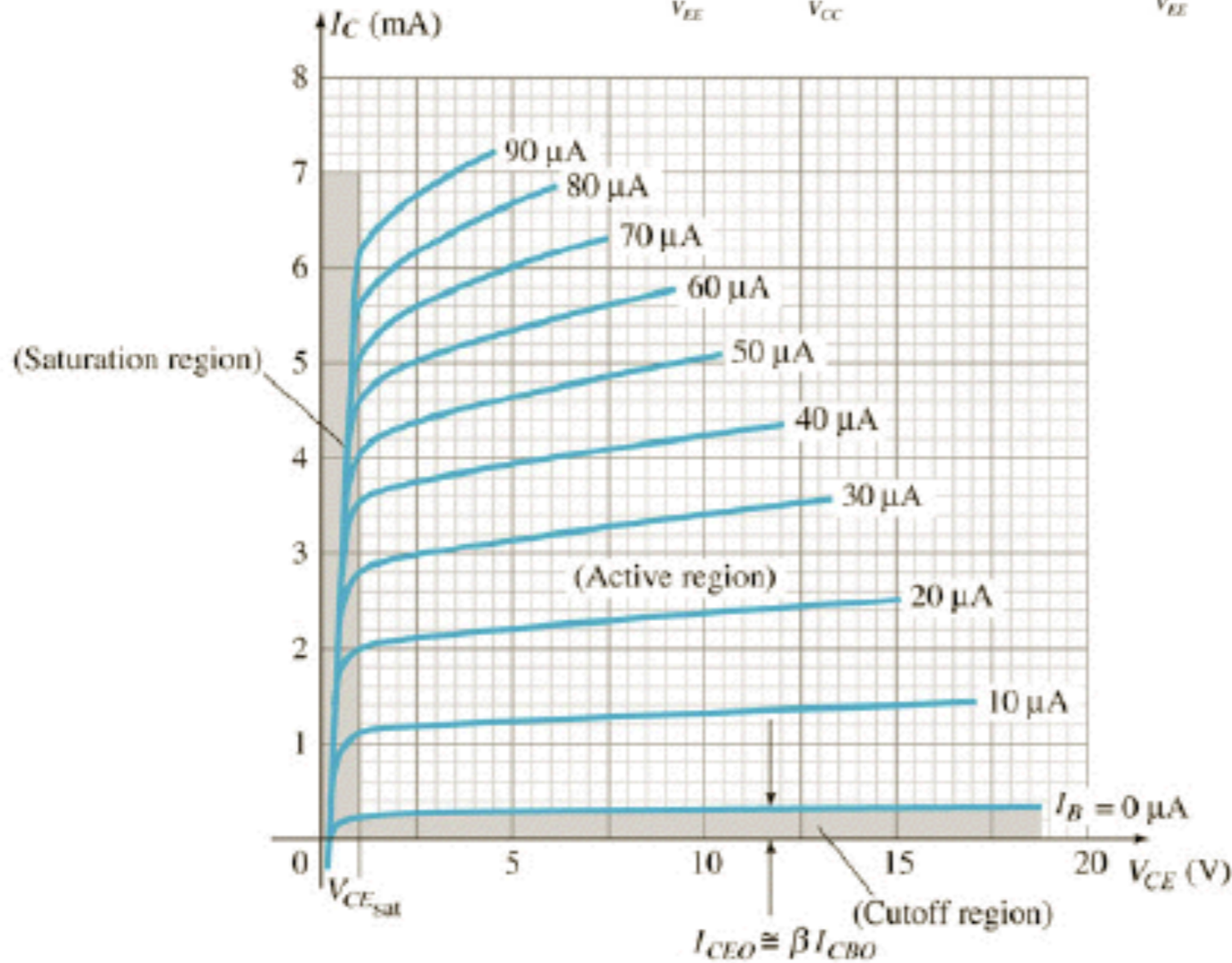
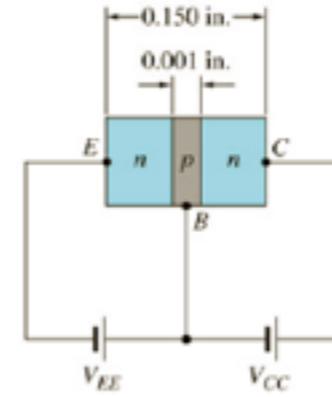
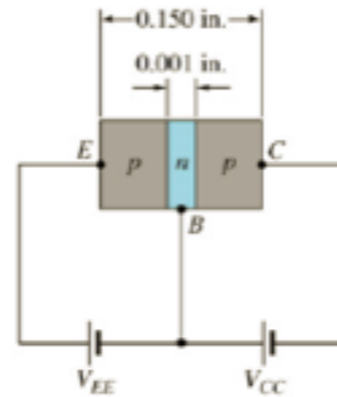

Électronique - Internet Explorer provided by Dell

http://www.univ-lemans.fr/enseignements/physique/02/electro/mnueltro.html

File Edit View Favorites Tools Help

Électronique

Électronique

Oscilloscope cathodique <ul style="list-style-type: none"> Principe Synchronisation Fonctionnement en bicourbe Figures de Lissajous Mesure de déphasage Mesure de fréquences Balayage télévision 	Diodes et transistors <ul style="list-style-type: none"> Pont de Graetz Filtrage (animation) Redressement et filtrage Régulateur à diode Zener Transistor (principe) Transistor en régime variable 	Filtres <ul style="list-style-type: none"> Filtres passifs (exemples) Filtres passifs (général) Filtres en L, T et Pi Filtres en T et T ponté Filtres de Sallen et Kay Filtres de Rauch 	Logique <ul style="list-style-type: none"> Portes logiques Associations de NANDs Associations de NORs Bascules R-S et D Bascules J-K Additionneur binaire
Circuits simples <ul style="list-style-type: none"> Amplificateur opérationnel Diviseur de tension Circuits RC. Filtres Dérivateur Intégrateur Circuits R, L, C série et // Relaxateur à néon Déphaseur passif Déphaseur à AOP Générateur de courant constant Adaptation d'impédances 	Commutation <ul style="list-style-type: none"> Astable Astable à comparateur Monostable Comparateur de Schmitt 	Convertisseurs <ul style="list-style-type: none"> Convertisseur N/A R-2R Convertisseur A/N simple rampe Convertisseur A/N à approximations 	Capteurs <ul style="list-style-type: none"> Thermistance Thermomètre à diode Thermomètre Pt500 Impédance d'un quartz
Divers	Divers		

Internet | Protected Mode: On 100%

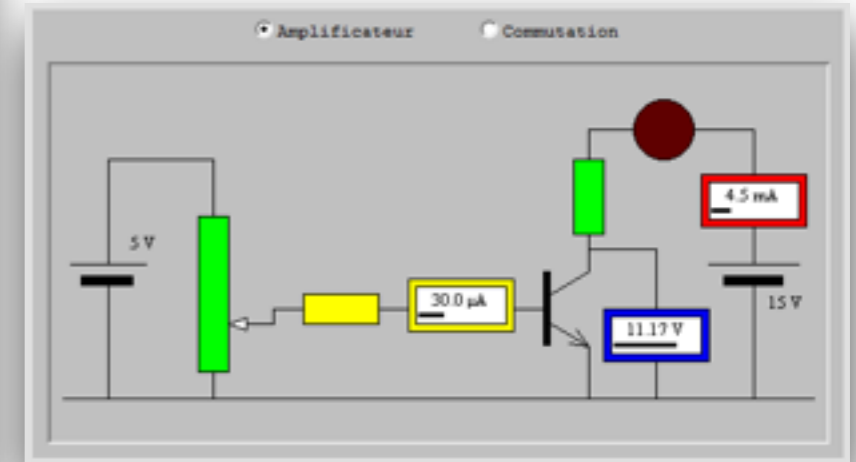

BJT x FET

FET - Transistor de efeito de campo

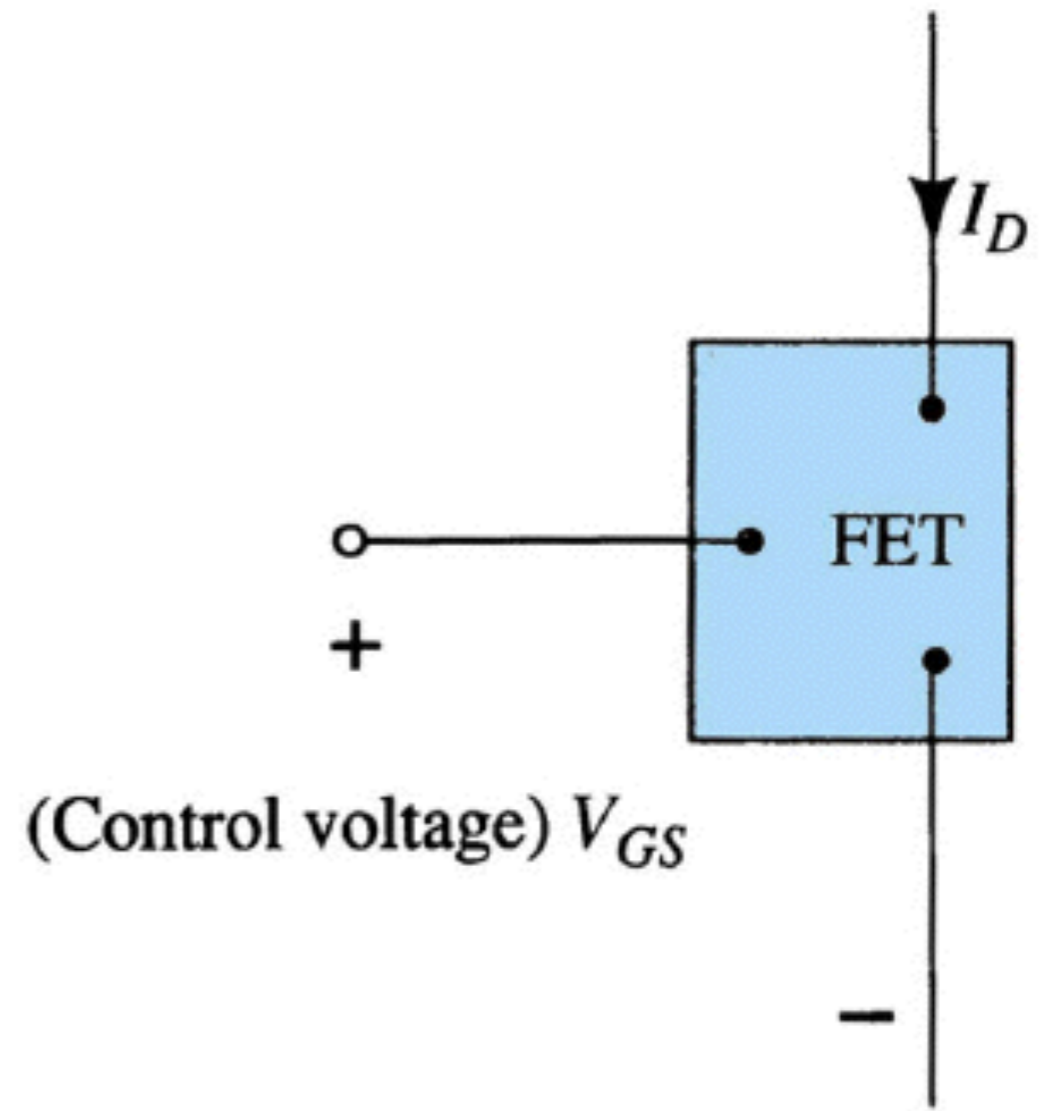
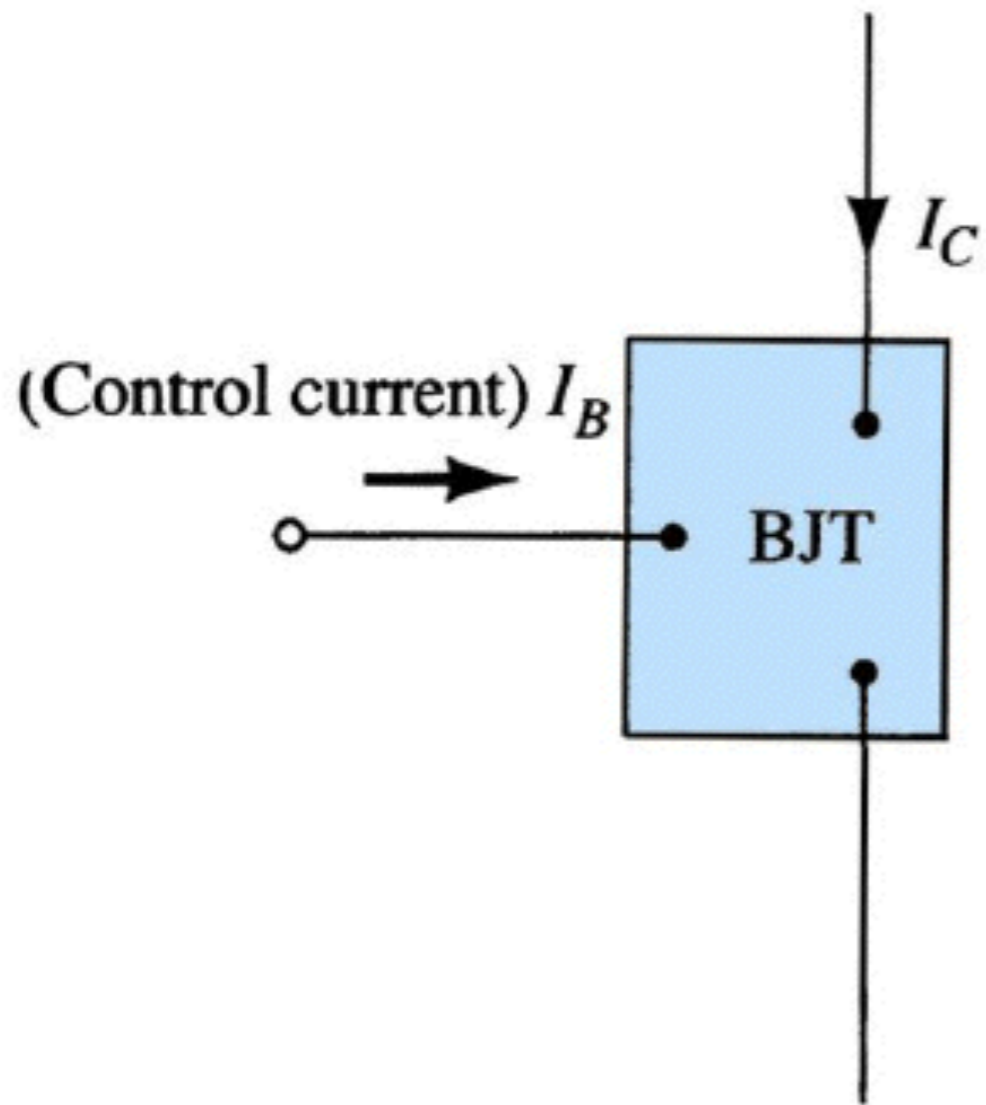

FET

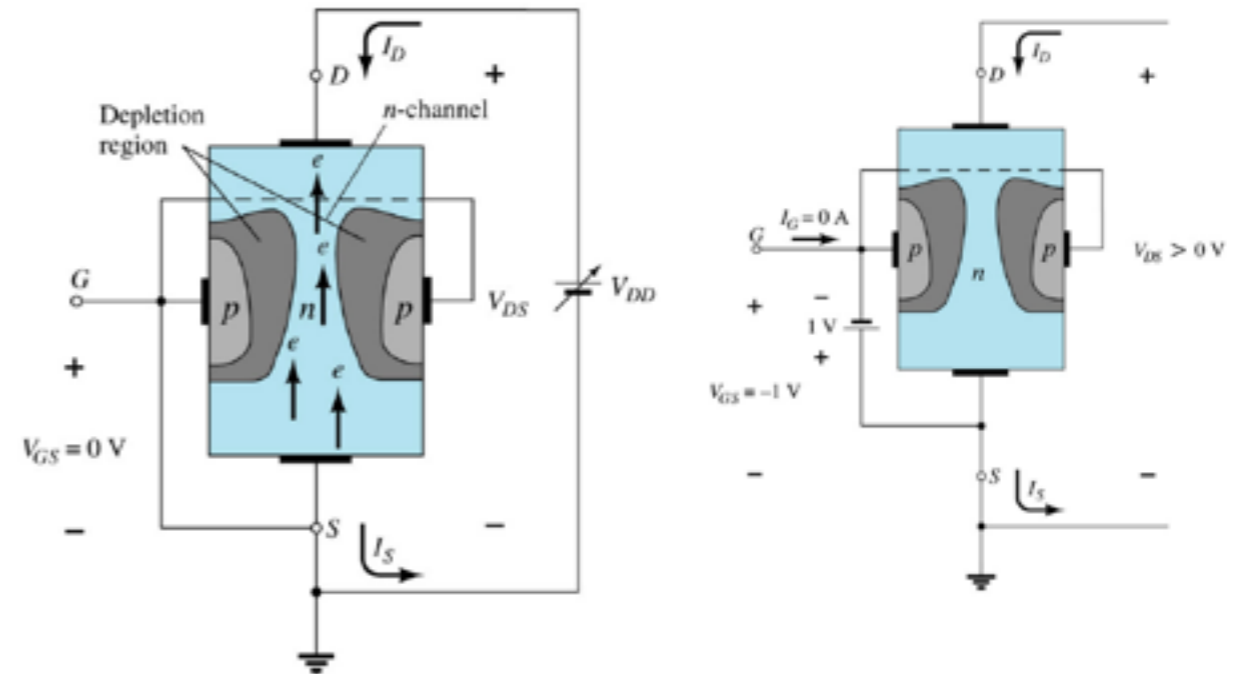
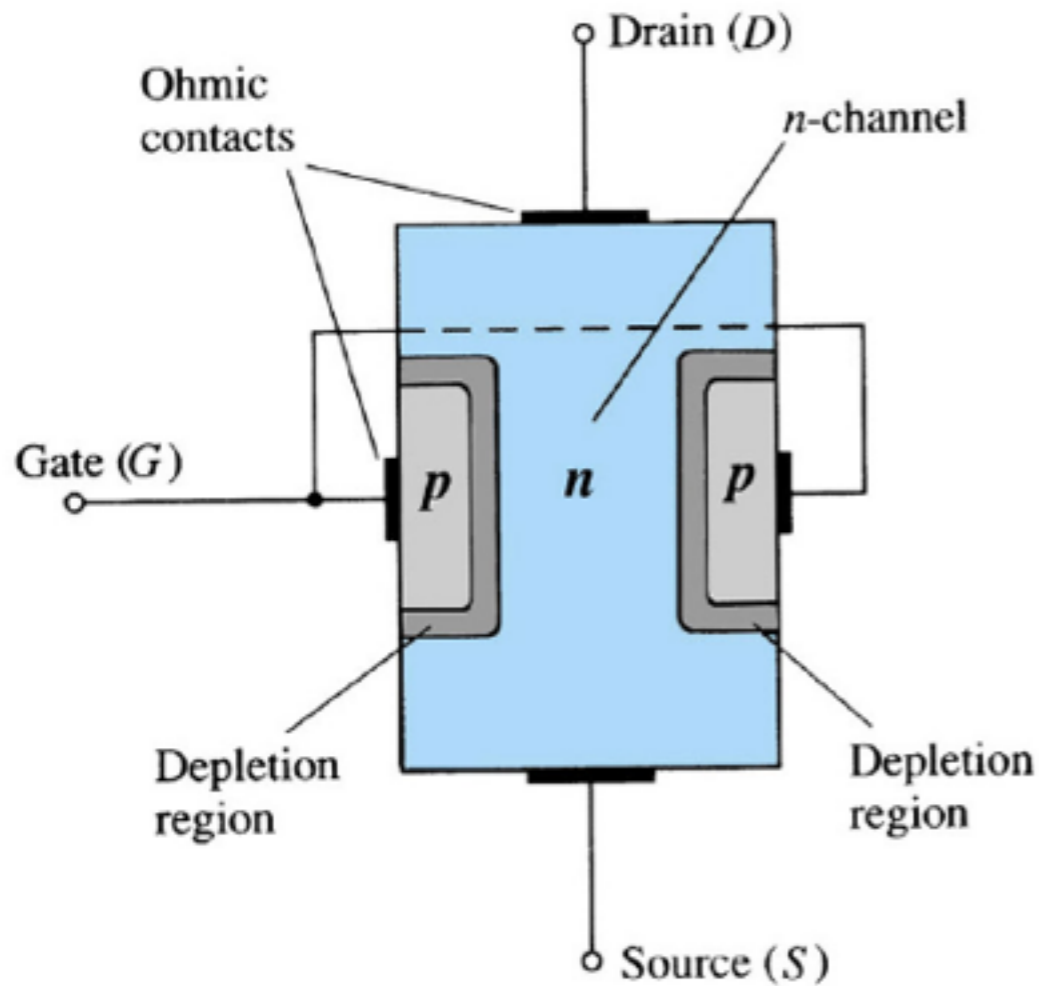

JFET: Operação básica

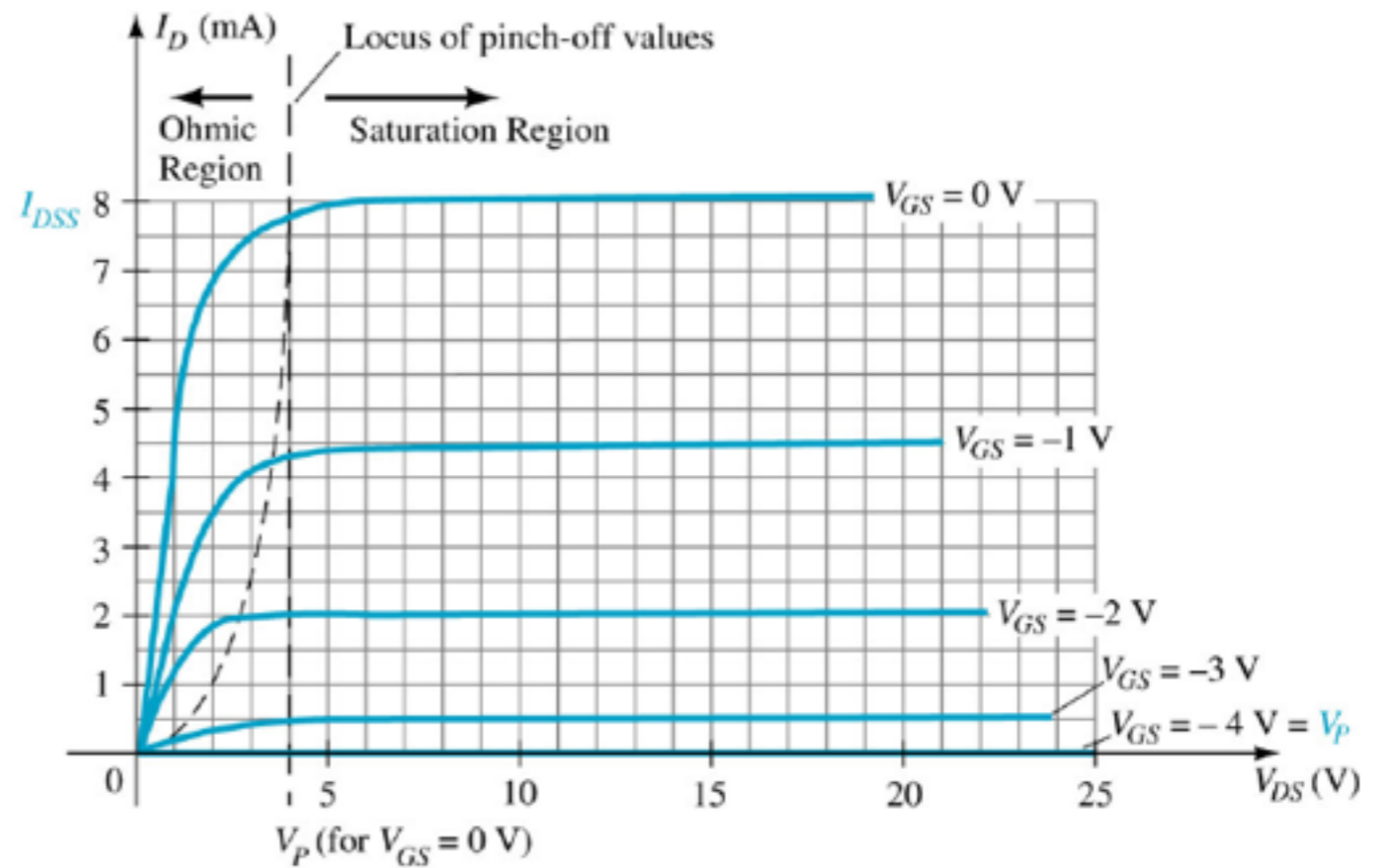

Semiconductor Applet Services - Internet Explorer provided by Dell

http://jas.eng.buffalo.edu/

File Edit View Favorites Tools Help

Semiconductor Applet Services

JAS

About

Educ Applets

Info

Java-related

Semicond.

Web sites

Education

Higher Ed.

Resources

Semiconductor

Links

Java API

Research

XRD Sites

Matr. Res.

Fed Agency

Done

Internet | Protected Mode: On

100%

The Semiconductor Applet Service

(Supported in part by the National Science Foundation)

List of Simulation Applets

- Crystal Structure**
 - Zincblende and Diamond structures (GaAs, Si, etc.): [unitcell with a list of material property](#). It gives you the 3D views of the unitcell and the covalent bonds.
 - [Hexagonal Closed Packed structures](#) (ZnS, GaN, SiC, etc.). An interactive 3D view of the crystal unitcell.
 - [Crystal Structure and the 14 Bravais Lattices](#) (java1.3): you can add various Basis atoms, rotate the crystal with one or multiple unitcells for a 3D view. It has many example crystals. You can also view the lattice planes and directions. [Crystal Structure in Java 3D !](#) (Java3D plugin maybe needed: use link in page)
- Energy Bands and Charge Carriers**
 - Visualization of [diffusion, drift and recombination](#) of excess minority carriers in a semiconductor.
 - [Indirect recombination via an energy state in the band gap](#). It also introduces the four basic processes in the Shockley-Read-Hall statistics.
 - Energy Band Diagram and E-k Diagram
 - [AlGaAs](#)
 - [SiGe](#)
- Charge Carriers and Fermi Level** [Semiconductor Statistics]
 - [Fermi Function and Localized Energy States](#) and the Temperature effect.

<http://jas.eng.buffalo.edu/>

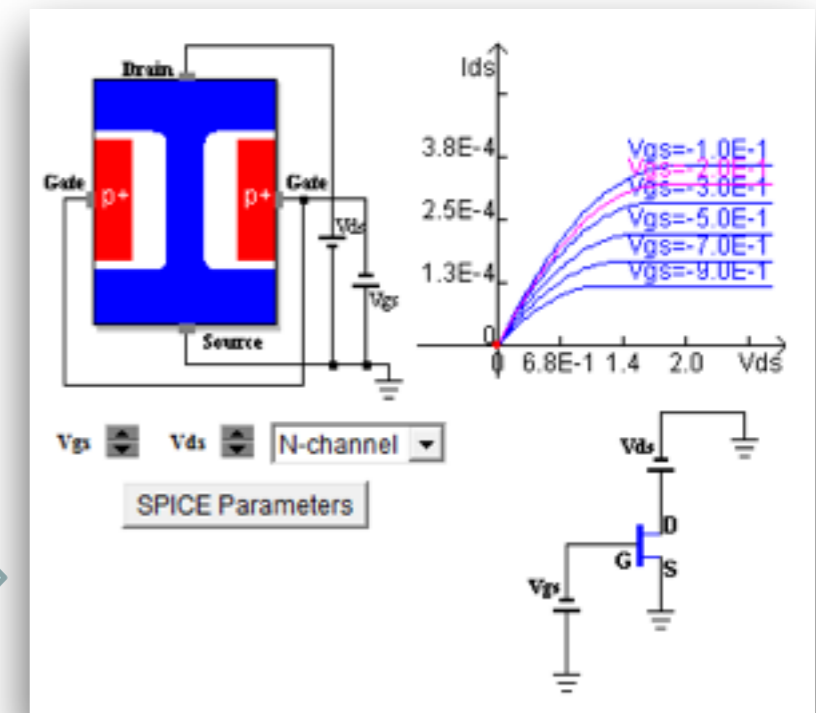
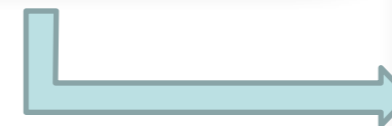

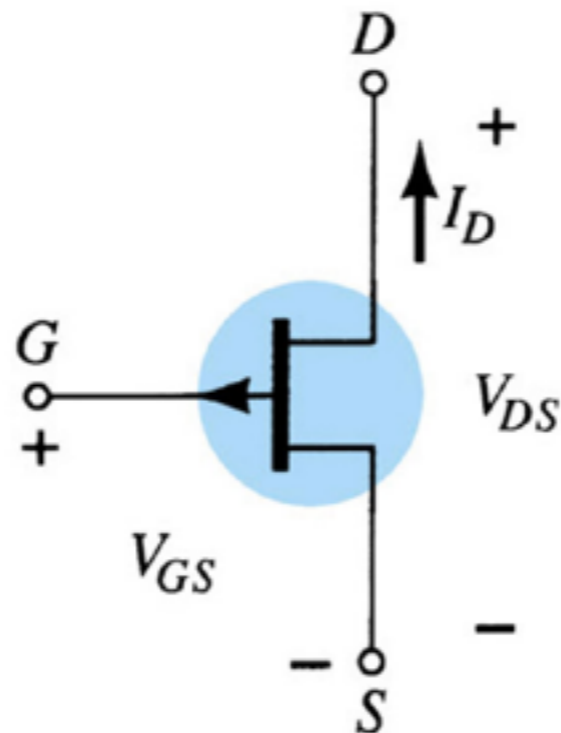
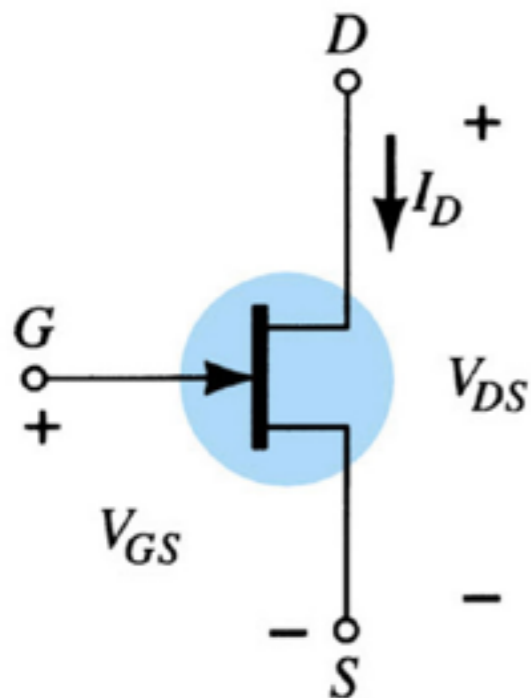

JFET canal n e canal p

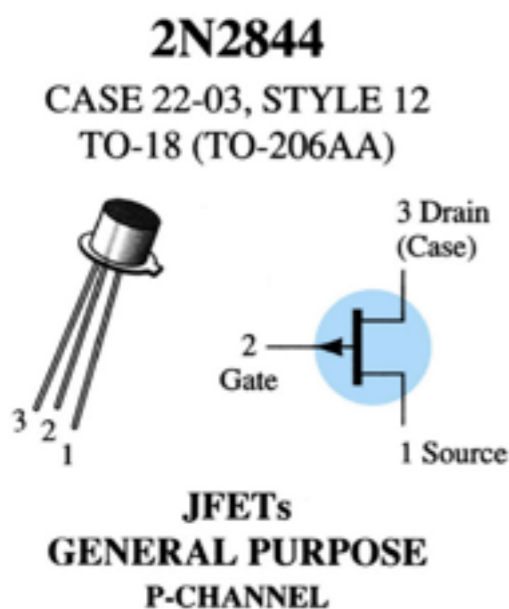
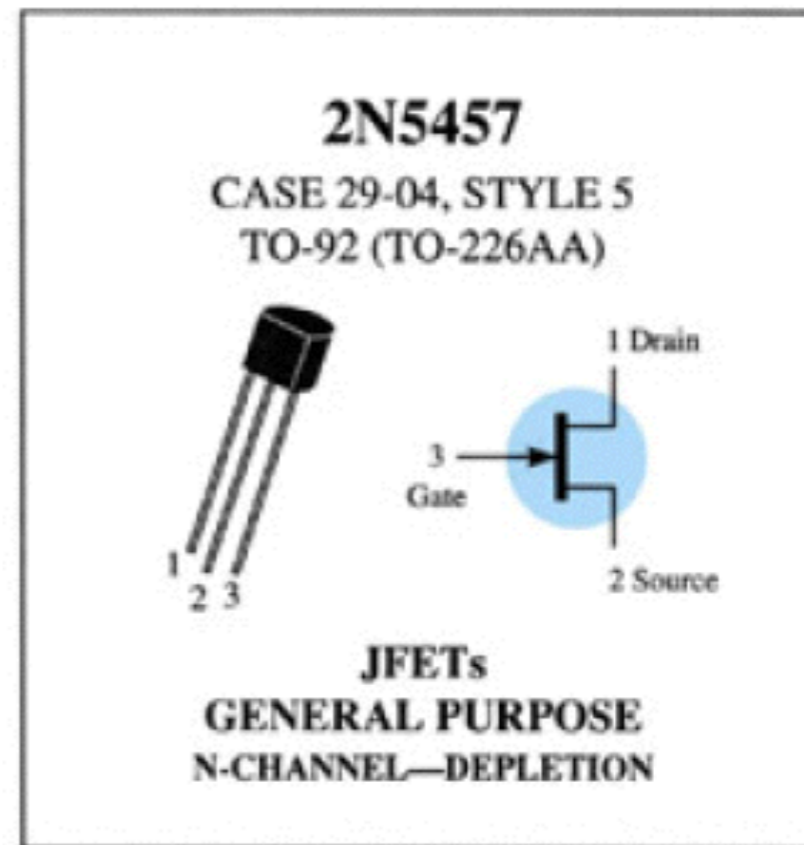

Positivo da Fonte Auxiliar

+ Vaux

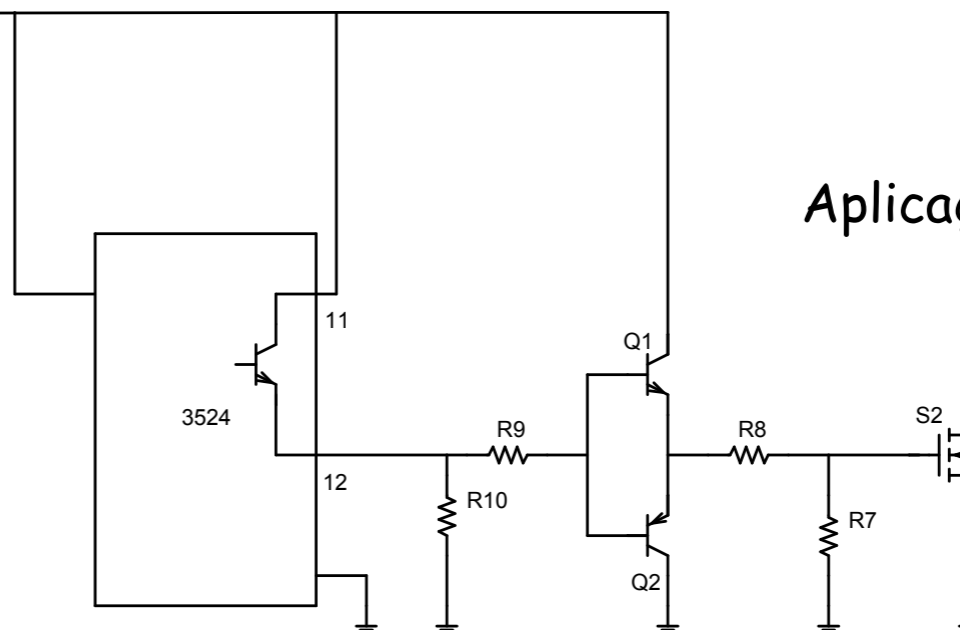

Aplicação do JFET

MOSFET

MOSFET - Metal Oxide Semiconductor Field Effect Transistor

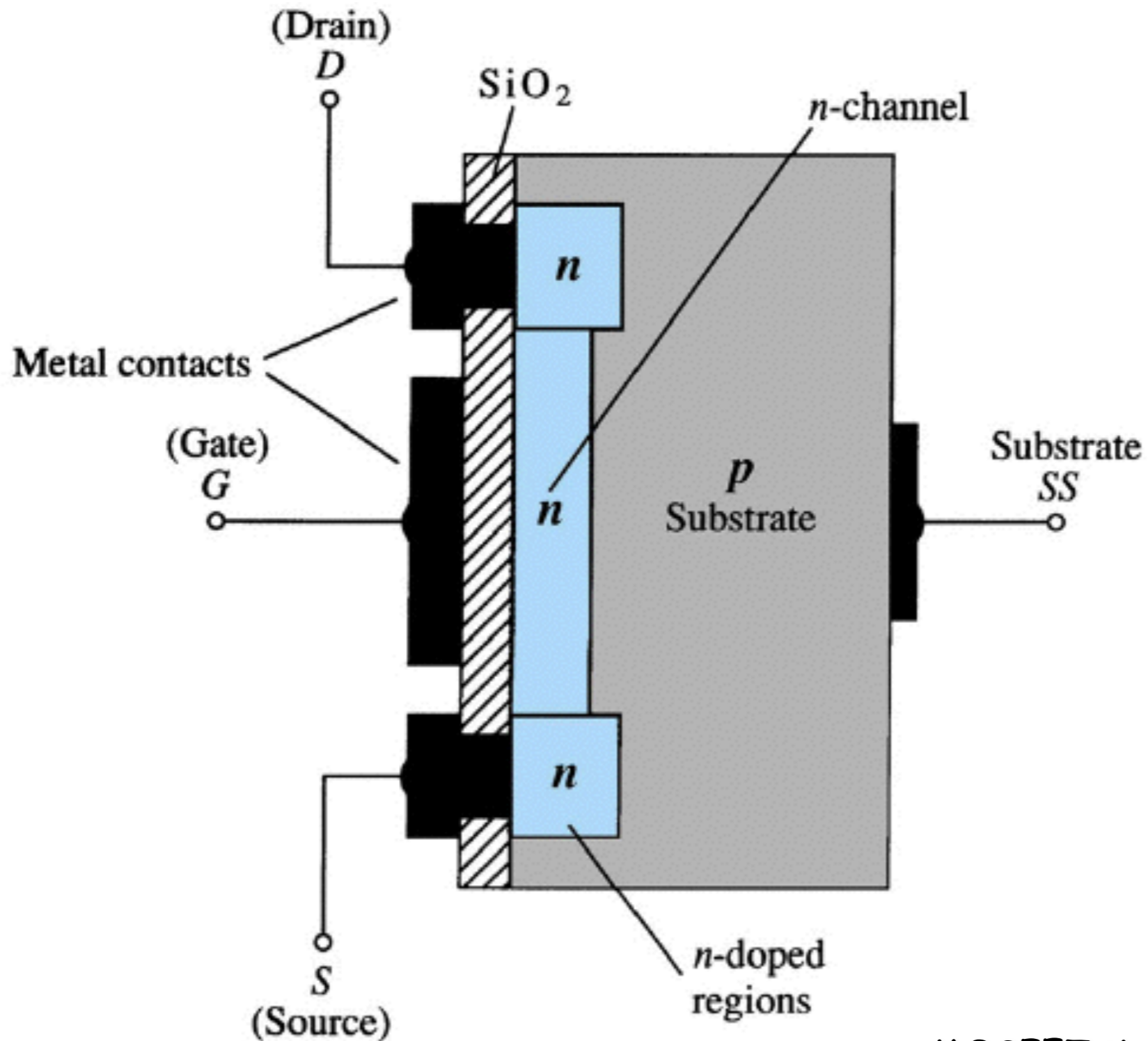

MOSFET tipo Depleção

MOSFET

MOSFET tipo Depleção

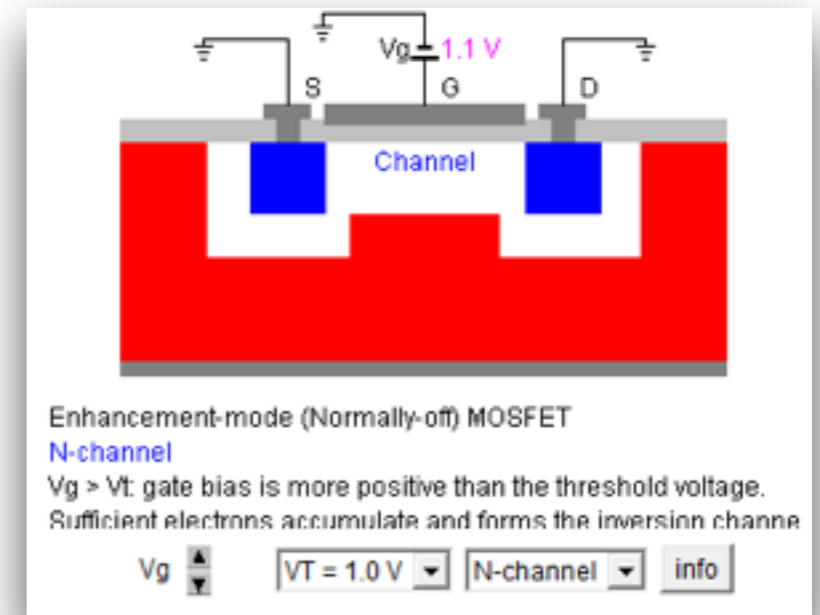
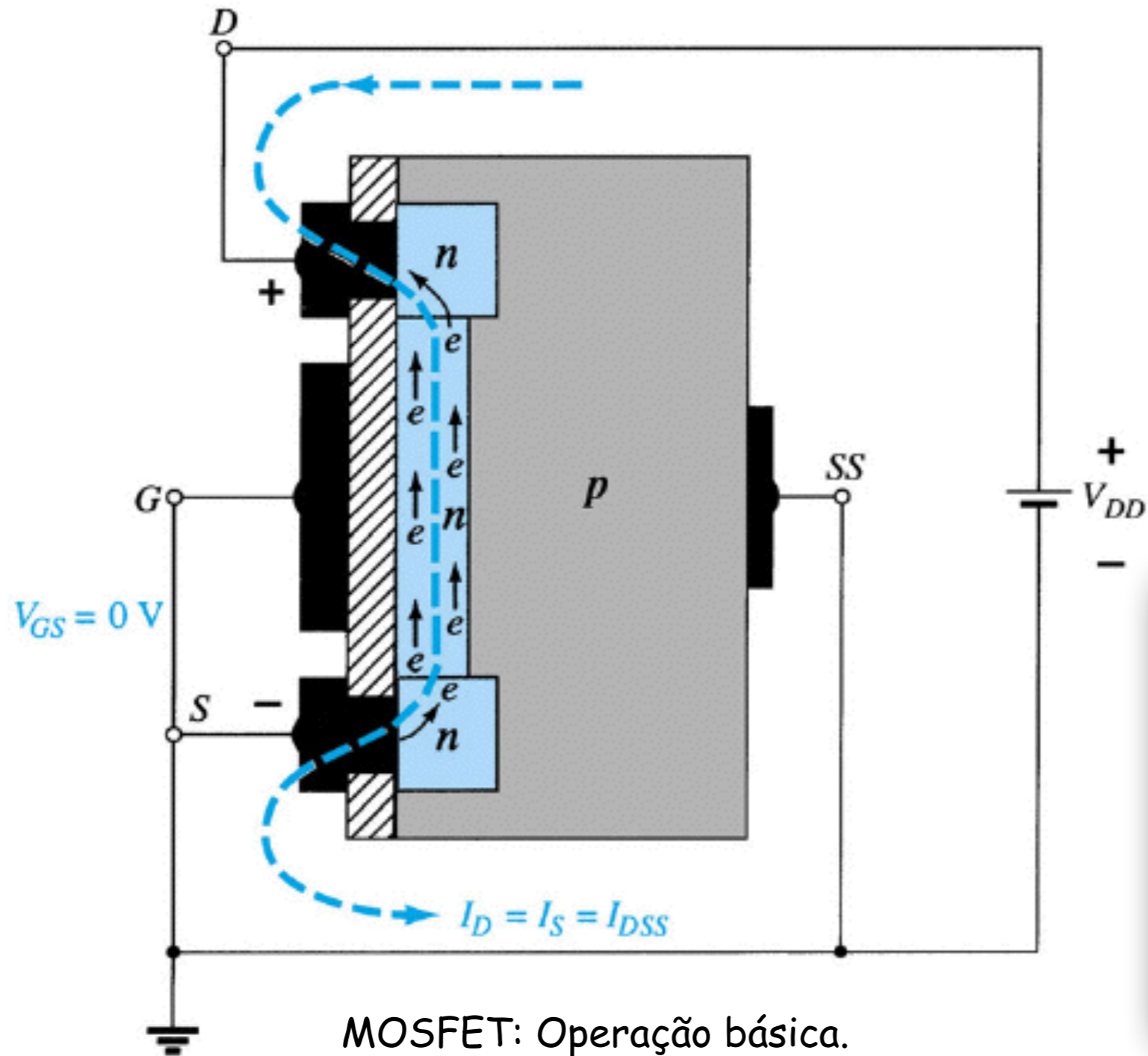

MOSFET tipo Depleção

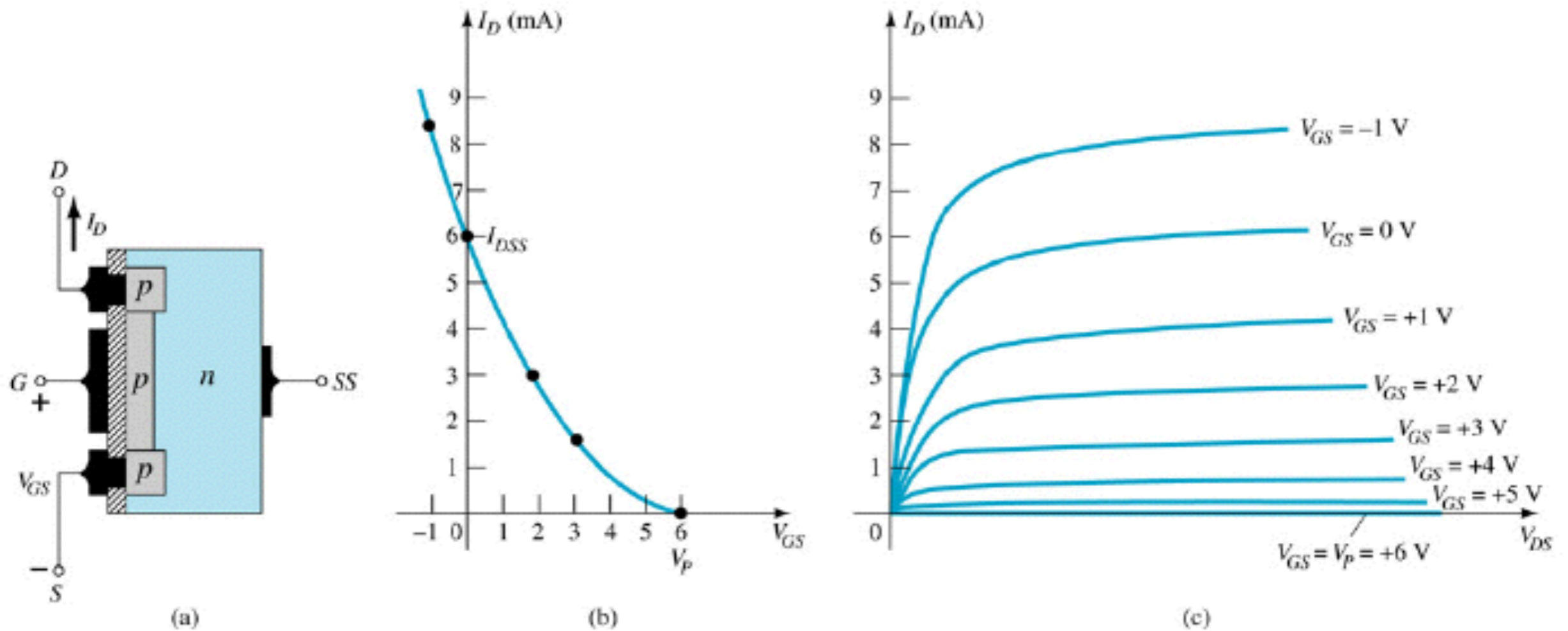

MOSFET: Operação básica.

MOSFET tipo Depleção

n-channel

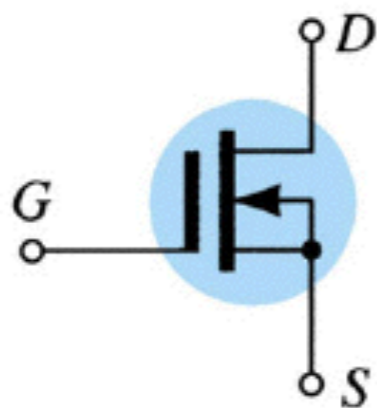
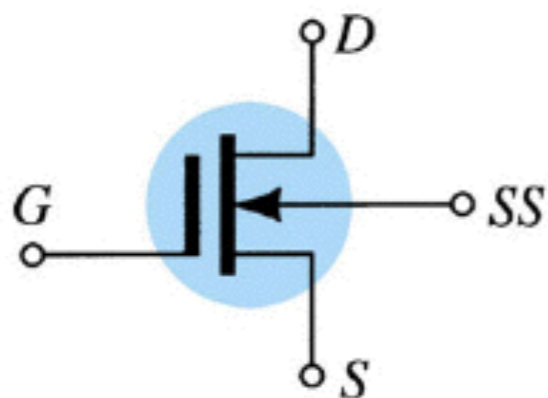

p-channel

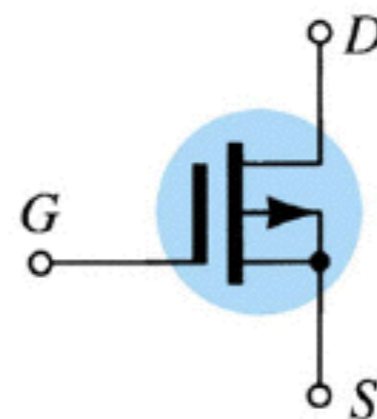
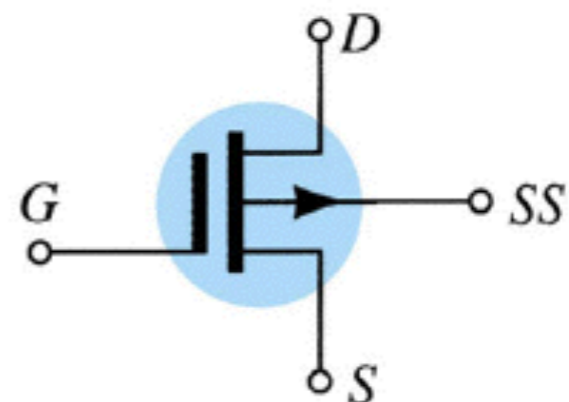

MOSFET tipo Intensificação

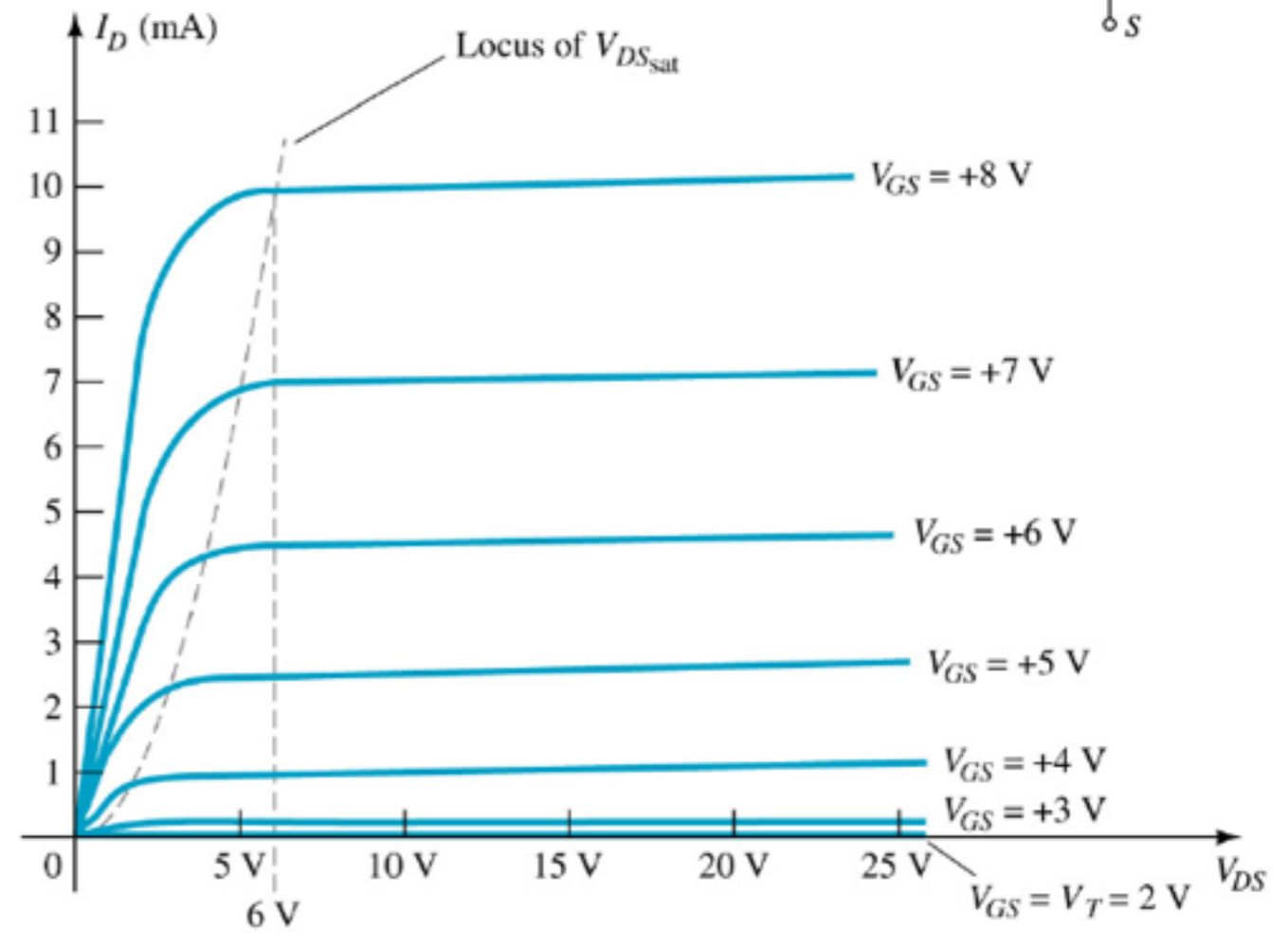
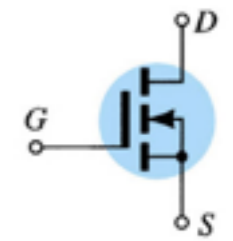
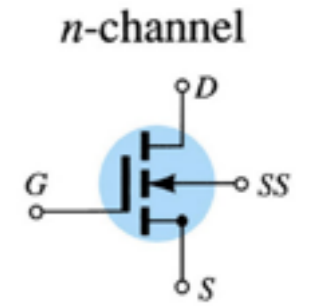
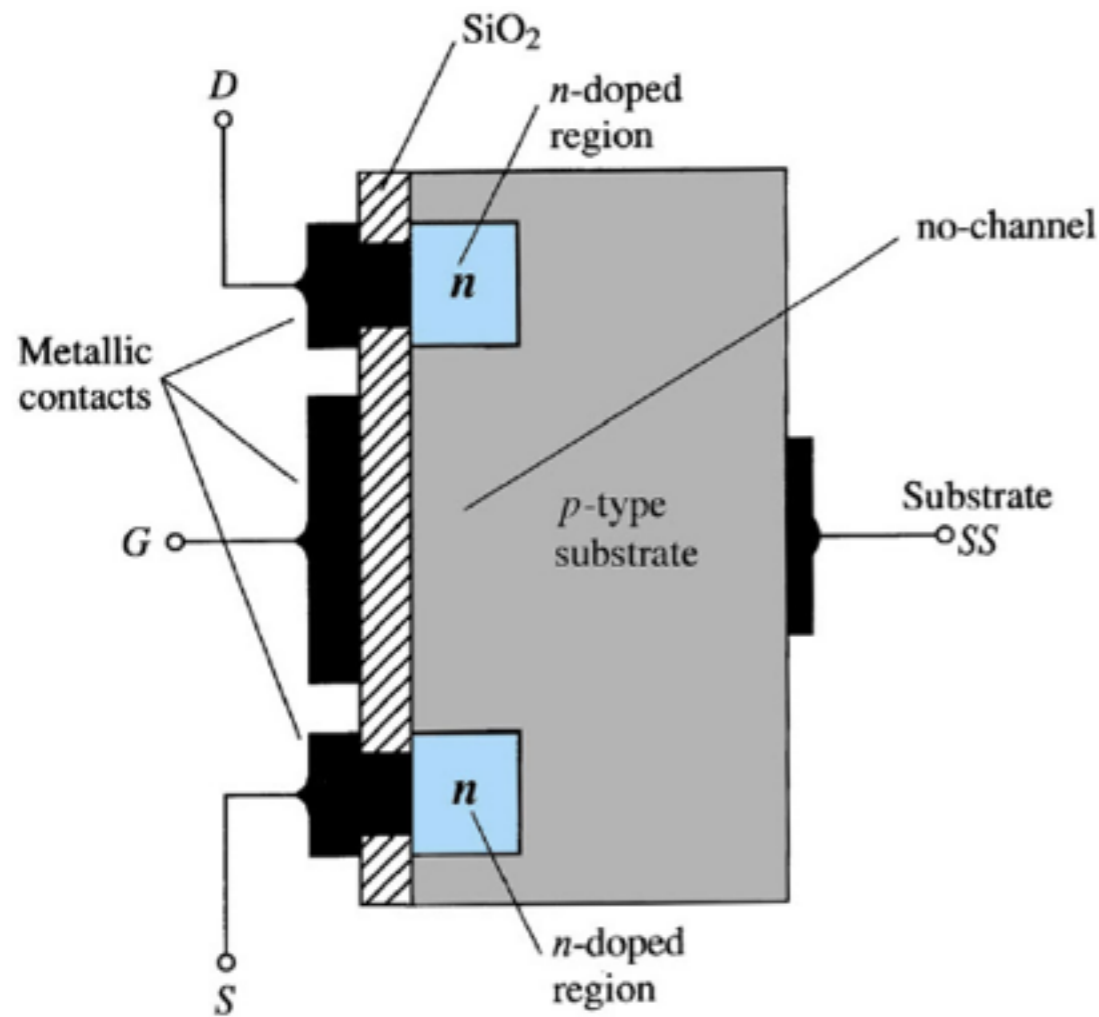

Canal n

MOSFET

MOSFET de Potência

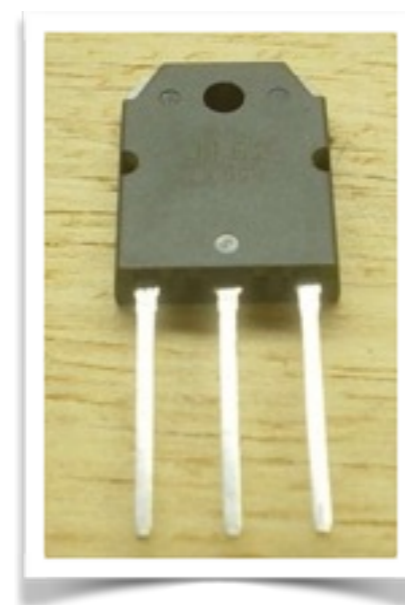
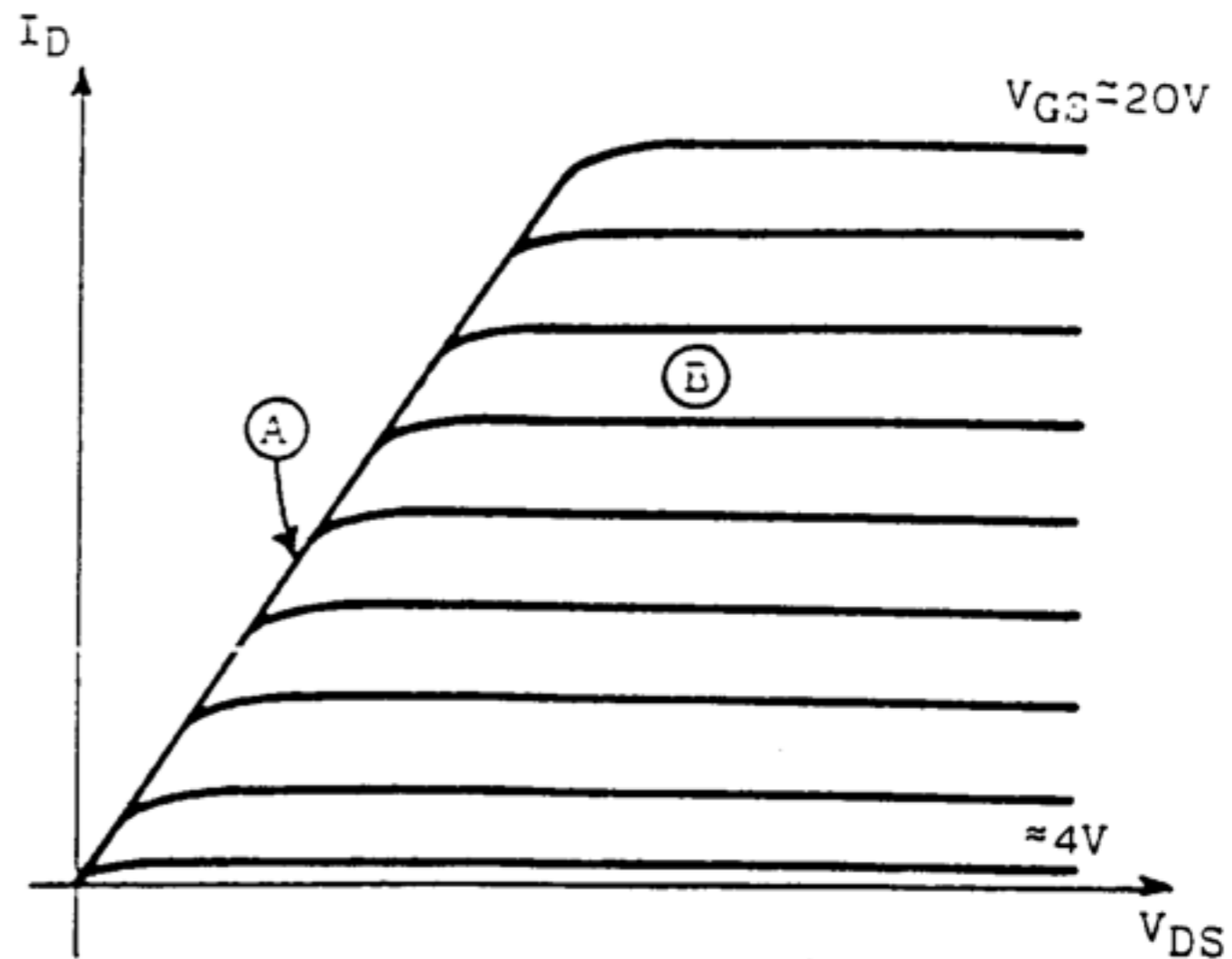
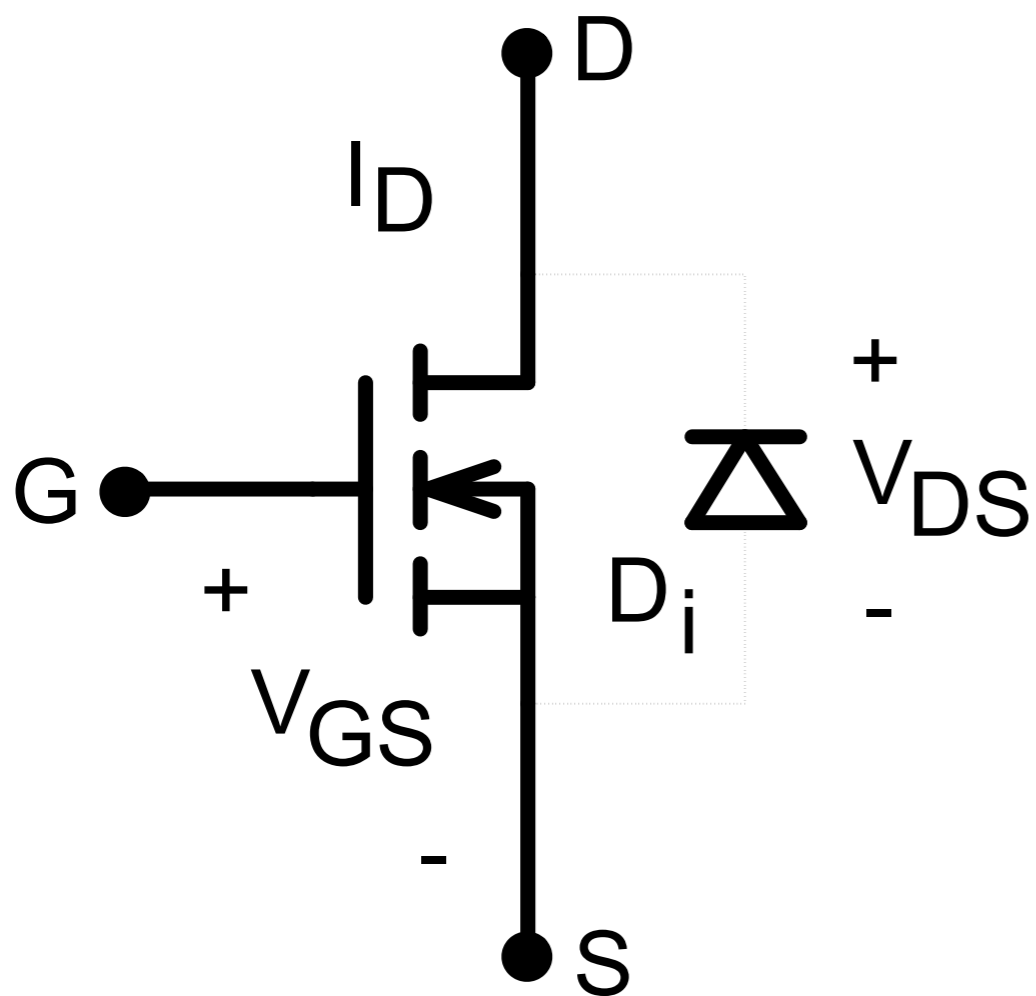

MOSFET

MOSFET de Potência

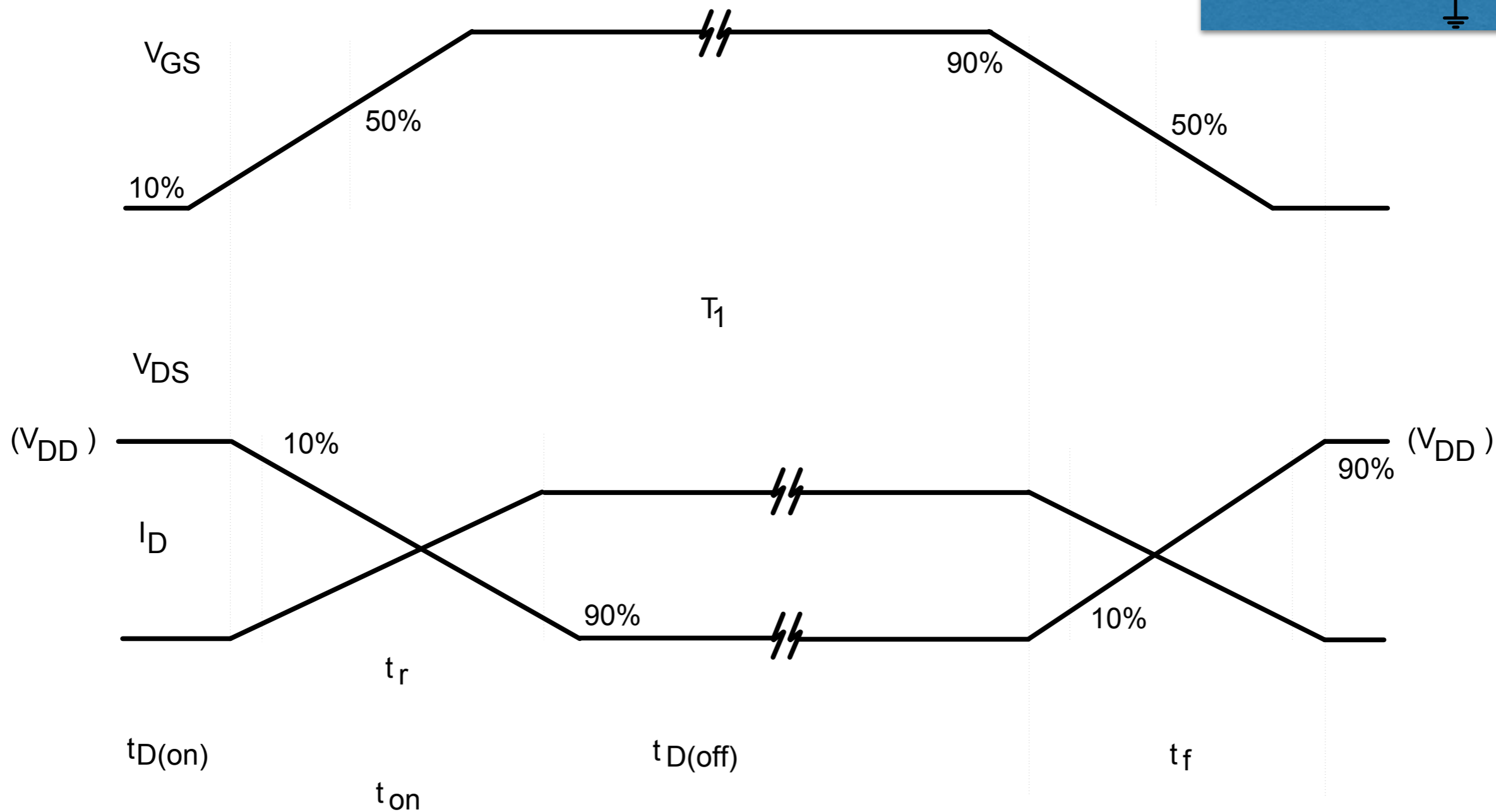
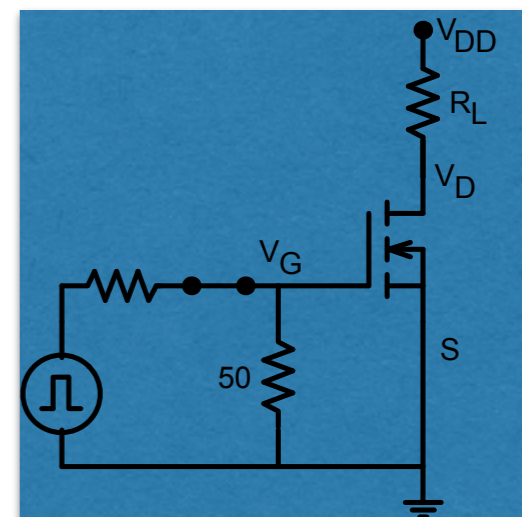

Comutação do MOSFET com carga resistiva

MOSFET de Potência

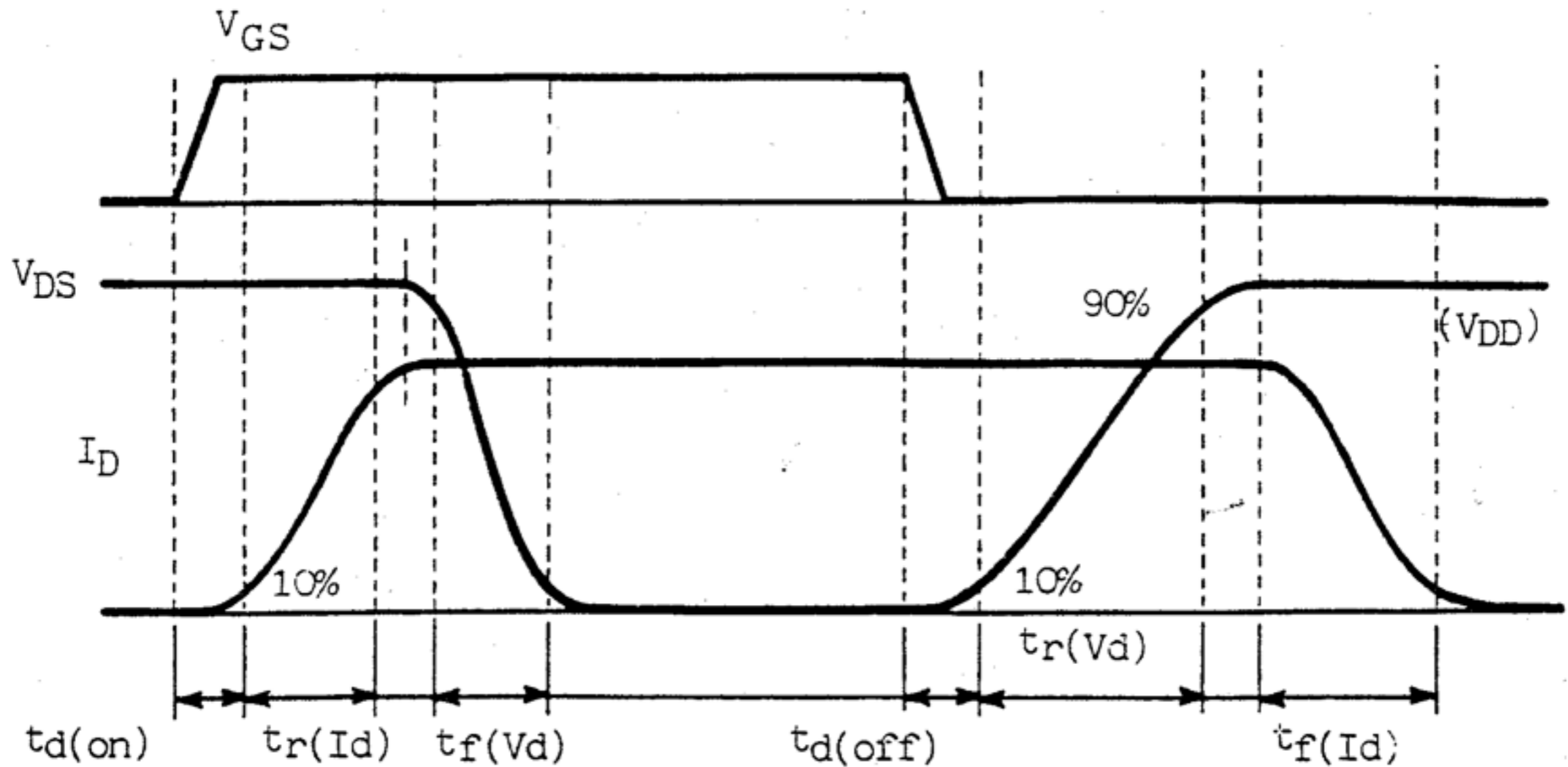
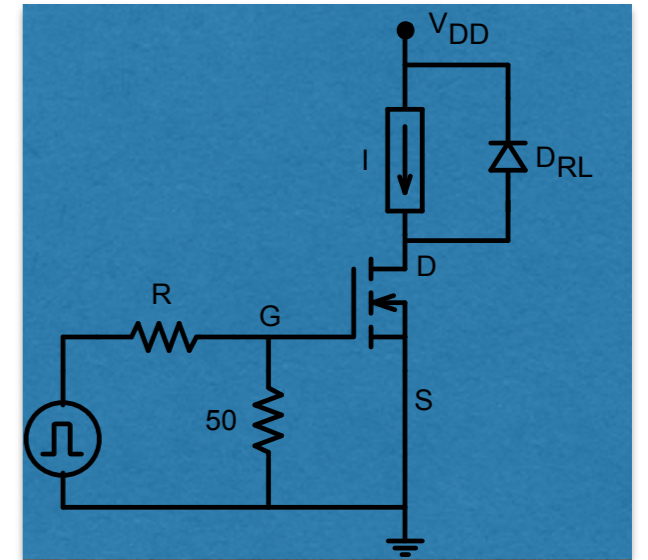

Comutação do MOSFET com carga indutiva

Classificação das perdas:

1. Condução;

$$P_{cond} = \frac{t_{on}}{T} \cdot r_{ds(on)} \cdot i_{d(on)}^2$$

2. Comutação:

- Entrada em condução e bloqueio;

- Onde:

$$t_f \cong t_{on}$$

$$t_r \cong t_{off}$$

Dados de catalogo:

International
IR Rectifier

PD - 94459A

IRFP150V

HEXFET® Power MOSFET

- Advanced Process Technology
- Ultra Low On-Resistance
- Dynamic dv/dt Rating
- 175°C Operating Temperature
- Fast Switching
- Fully Avalanche Rated

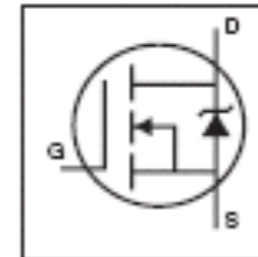

$$V_{DS} = 100V$$

$$R_{DS(on)} = 24m\Omega$$

$$I_D = 47A$$

Description

Advanced HEXFET® Power MOSFETs from International Rectifier utilize advanced processing techniques to achieve extremely low on-resistance per silicon area. This benefit, combined with the fast switching speed and ruggedized device design that HEXFET power MOSFETs are well known for, provides the designer with an extremely efficient and reliable device for use in a wide variety of applications.

The TO-247 package is preferred for commercial-industrial applications where higher power levels preclude the use of TO-220 devices. The TO-247 is similar but superior to the earlier TO-218 package because of its isolated mounting hole.



Absolute Maximum Ratings

	Parameter	Max.	Units
$I_D @ T_C = 25^\circ C$	Continuous Drain Current, $V_{GS} @ 10V$	48	A
$I_D @ T_C = 100^\circ C$	Continuous Drain Current, $V_{GS} @ 10V$	32	
I_{DM}	Pulsed Drain Current $\text{\textcircled{D}}$	230	
$P_D @ T_C = 25^\circ C$	Power Dissipation	140	W
	Linear Derating Factor	0.01	W/°C
V_{GS}	Gate-to-Source Voltage	± 20	V
I_{AS}	Avalanche Current $\text{\textcircled{D}}$	28	A
E_{AS}	Repetitive Avalanche Energy $\text{\textcircled{D}}$	20	mJ
dv/dt	Peak Diode Recovery dv/dt $\text{\textcircled{D}}$	5.8	V/ns
T_J	Operating Junction and	-55 to +175	°C
T_{STG}	Storage Temperature Range		
	Soldering Temperature, for 10 seconds		
	Mounting torque, 6-32 or M3 screw	10 lbf-in (1.1 N-m)	

Thermal Resistance

	Parameter	Typ.	Max.	Units
$R_{\theta JC}$	Junction-to-Case	—	1.1	°C/W
$R_{\theta CS}$	Case-to-Sink, Flat, Greased Surface	0.24	—	
$R_{\theta JA}$	Junction-to-Ambient	—	40	

MOSFET

Quando usar MOSFET:

1. Frequências altas (acima de 50 kHz);
2. Tensões muito baixas (< 500 V);
3. Potências baixas (< 1 kW).

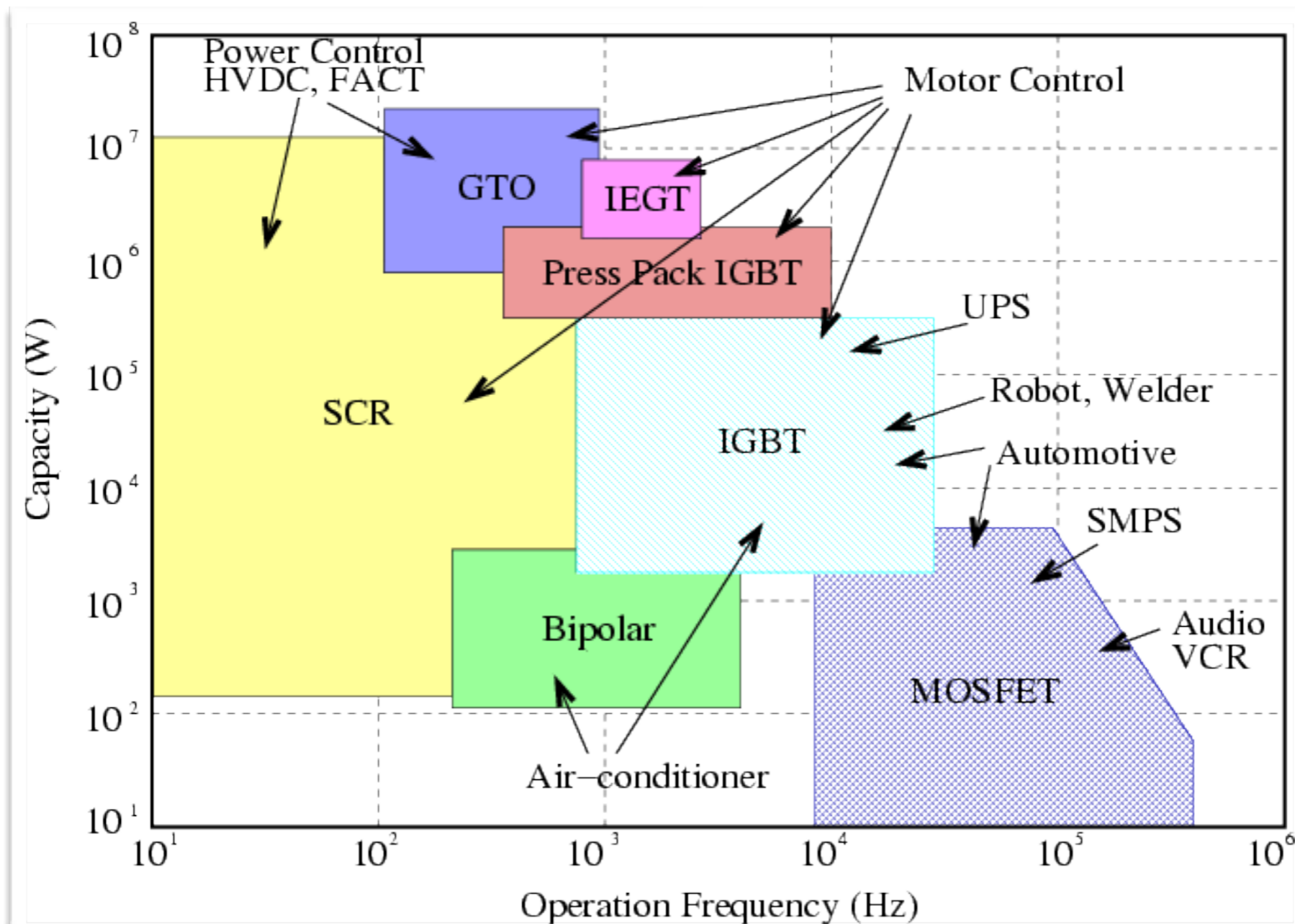

Demonstração

Demo

- Testes de MOSFET com multímetro.



IGBT

IGBT - Insulated Gate Bipolar Transistor

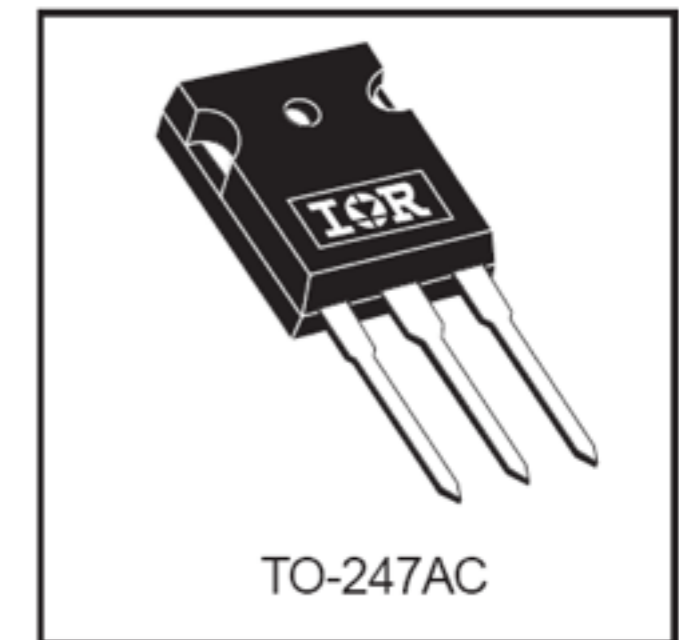
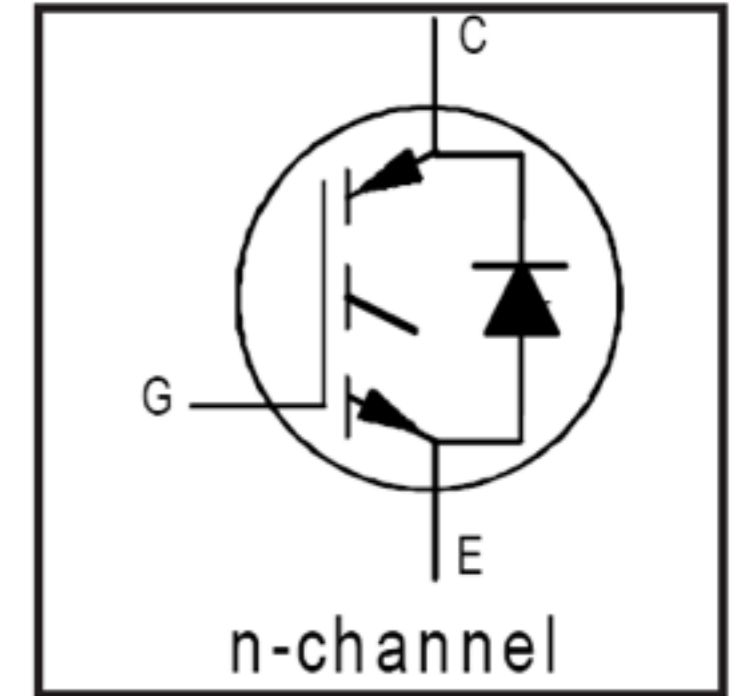
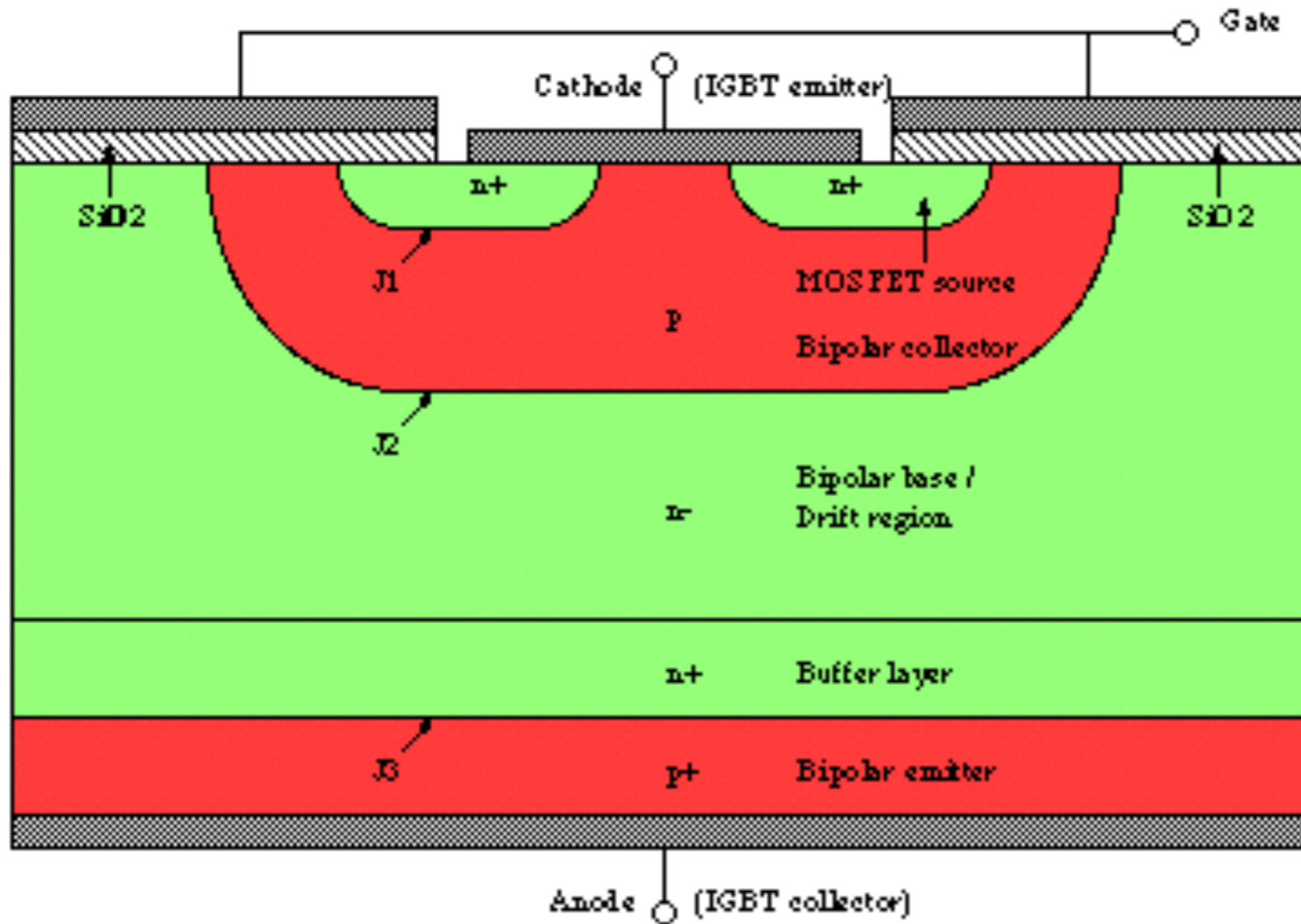

Características de BJT e MOSFET

Classificação das perdas:

1. Condução;

$$P_{cond} = \left(i_C \cdot V_{CEsat} + i_B \cdot V_{BEsat} \right) \cdot t_{on} \cdot f$$

0

2. Comutação:

- Entrada em condução e bloqueio;

- Onde:

$$P_{com} = \frac{1}{2} (t_r + t_f) \cdot I \cdot E \cdot f$$

Detalhamento do cálculo de perdas



Quando usar IGBT:

1. Frequências baixas (menor que 50 kHz);
2. Tensões altas (> 500 V);
3. Potências altas (> 1 kW).



Part	Family	Package	Circuit	Switching Speed
IRG4PH30K	IGBT Discretes	TO-247AC	Discrete	ULTRAFAST 4-20 kHz
IRG4PC20U	IGBT Discretes	TO-247AC	Discrete	ULTRAFAST 8-60 kHz
IRG4PC20S	IGBT Discretes	TO-247AC	Discrete	DC-1 kHz (STANDARD)
IRG4PC60U	IGBT Discretes	TO-247AC	Discrete	ULTRAFAST 8-60 kHz
IRG4BC30W	IGBT Discretes	TO-220AB	Discrete	WARP 60-150 kHz
IRG830B60K	IGBT Discretes	TO-220AB	Discrete	ULTRAFAST 10-30 kHz
IRG8B60K	IGBT Discretes	TO-220AB	Discrete	ULTRAFAST 10-30 kHz
IRG8B60K	IGBT Discretes	D2-Pak	Discrete	ULTRAFAST 10-30 kHz
IRG314C40L	IGBT Discretes	D2-Pak	Discrete	Low-Vce(on)
IRGPH020	IGBT Discretes	TO-247AC	Discrete	Low-Vce(on)

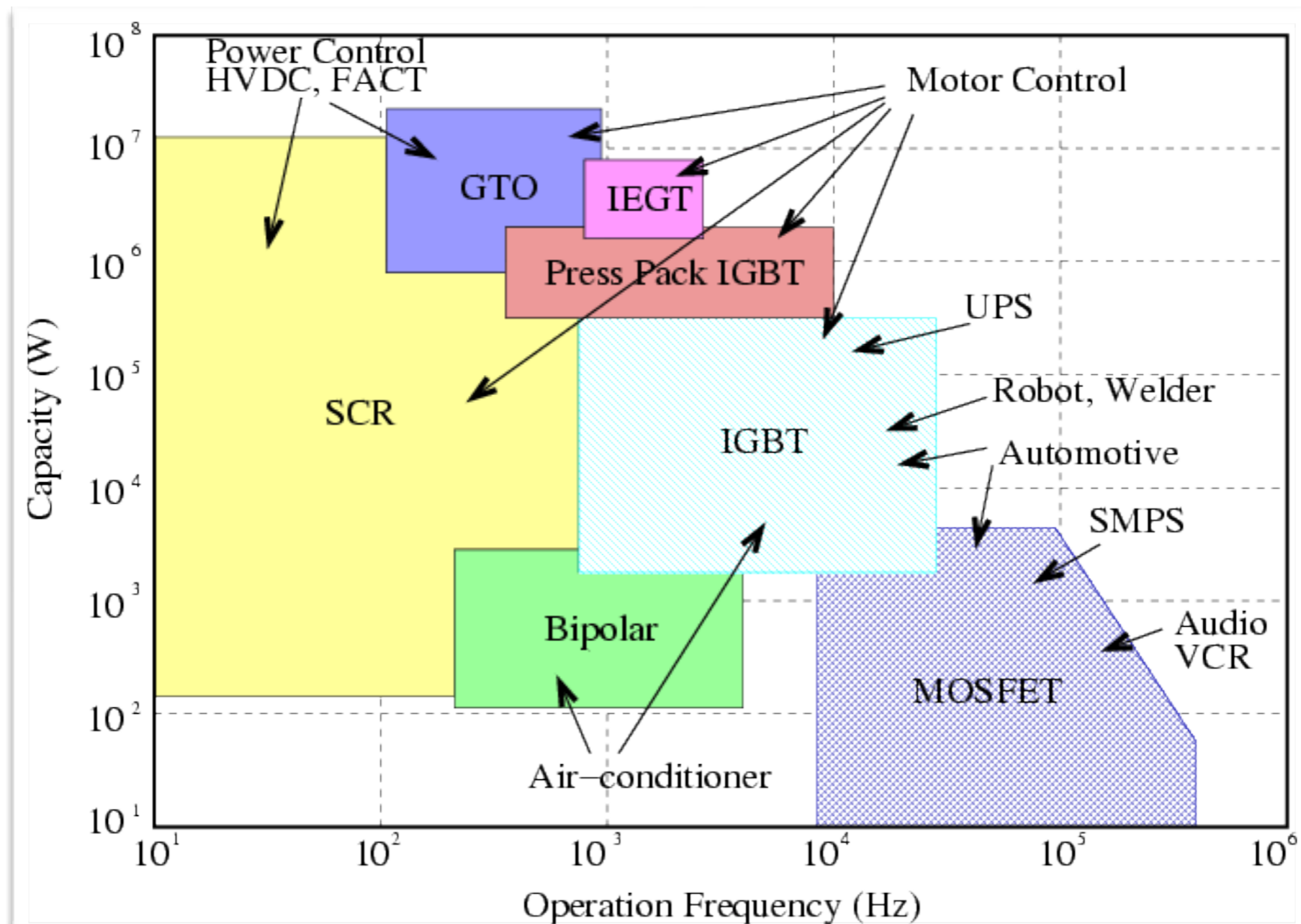

Quando usar IGBT:

1. Freqüências baixas (menor que 50 kHz);
2. Tensões altas (> 500 V);
3. Potências altas (> 1 kW).



www.irf.com

Part	Family	Package	Circuit	Switching Speed	V _{CE(S)} (V)	V _{CE(ON)} (V)	I _{C @ 25C} (A)	I _{C @ 100C} (A)	PD @25C (W)
▲ ▼	▲ ▼	▲ ▼	▲ ▼	▲ ▼	▲ ▼	▲ ▼	▲ ▼	▲ ▼	▲ ▼
IRG4PH30K	IGBT Discretos	TO-247AC	Discrete	ULTRAFAST 4-20 kHz	1200	4.20	20	10	100
IRG4PC20U	IGBT Discretos	TO-247AC	Discrete	ULTRAFAST 8-60 kHz	600	2.1	13	6.5	60
IRG4PC30S	IGBT Discretos	TO-247AC	Discrete	DC-1 kHz (STANDARD)	600	1.60	34	18	100
IRG4PC60U	IGBT Discretos	TO-247AC	Discrete	ULTRAFAST 8-60 kHz	600	2.00	75	40	520
IRG4BC30W	IGBT Discretos	TO-220AB	Discrete	WARP 60-150 kHz	600	2.70	23	12	100
IRGB30B60K	IGBT Discretos	TO-220AB	Discrete	ULTRAFAST 10-30 kHz	600	2.35	78	50	370
IRGB8B60K	IGBT Discretos	TO-220AB	Discrete	ULTRAFAST 10-30 kHz	600	2.2	17	9.0	140
IRGS6B60K	IGBT Discretos	D2-Pak	Discrete	ULTRAFAST 10-30 kHz	600	1.80	13	7	90
IRGS14C40L	IGBT Discretos	D2-Pak	Discrete	Low-Vceon	430	1.40	20	14	125
IRGP4050	IGBT Discretos	TO-247AC	Discrete	Low-Vceon	250	1.90	104	56	330

Encapsulamentos:



www.semikron.com



SEMISTRANS™



SEMiX®



SKiM™



MiniSKiiP®

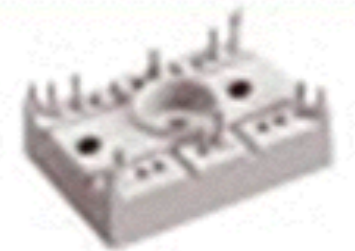

SEMITOP®

Encapsulamentos:

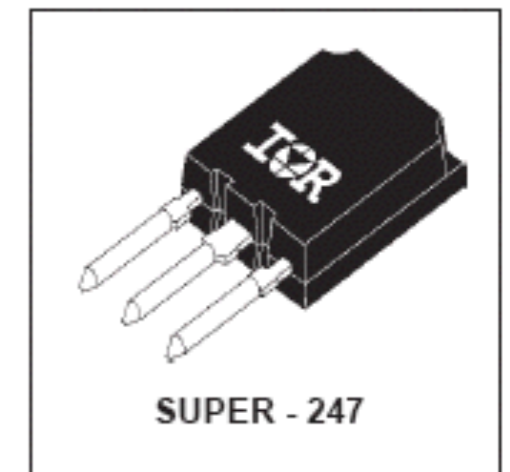
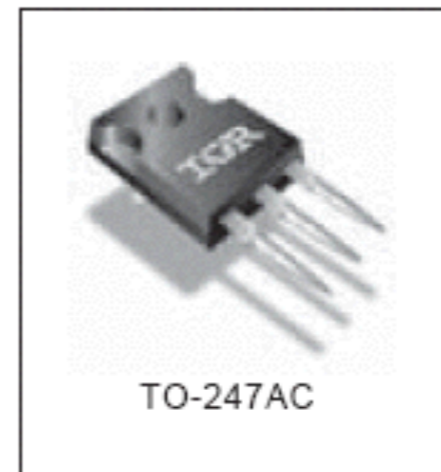
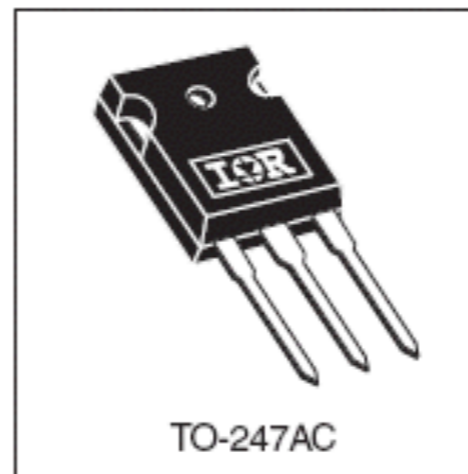
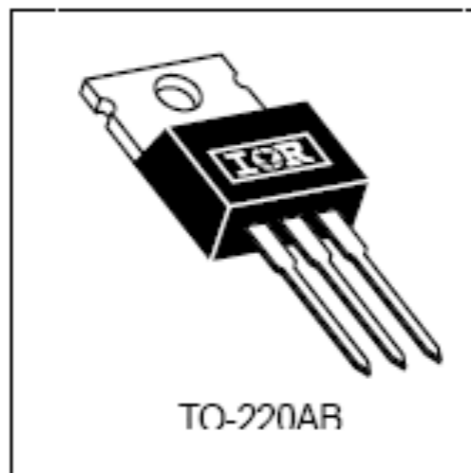
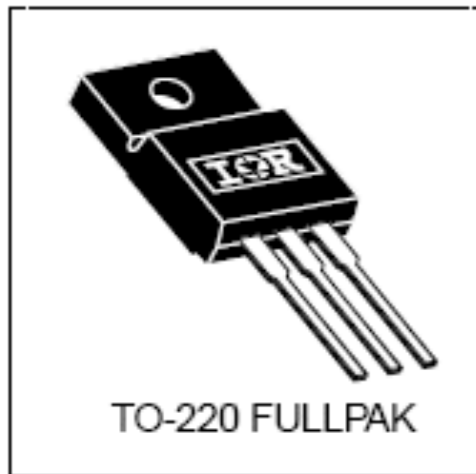
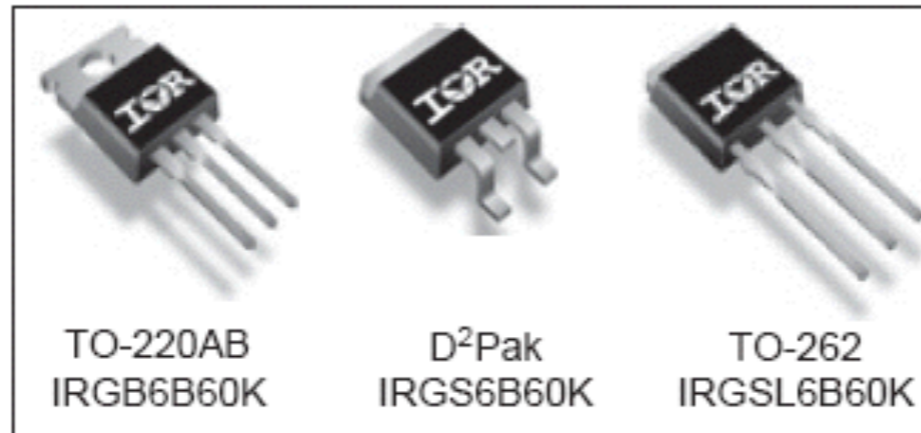
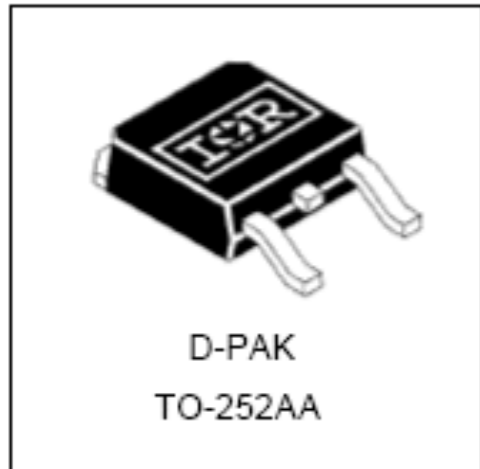

www.irf.com



Dados de catalogo:

International IR Rectifier INSULATED GATE BIPOLAR TRANSISTOR

PD - 94443

IRG4PC60U UltraFast Speed IGBT

Features

- UltraFast: Optimized for high operating frequencies up to 50 kHz in hard switching, >200 kHz in resonant mode.
- Generation 4 IGBT design provides tighter parameter distribution and higher efficiency.
- Industry standard TO-247AC package.

Benefits

- Generation 4 IGBT's offer highest efficiency available.
- IGBT's optimized for specified application conditions.
- Designed for best performance when used with IR Hexfred & IR Fred companion diodes.

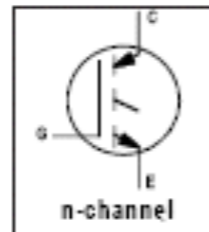

$V_{CES} = 600V$
$V_{CE(sat)} \text{ typ.} = 1.6V$
@ $V_{GE} = 15V, I_C = 40A$

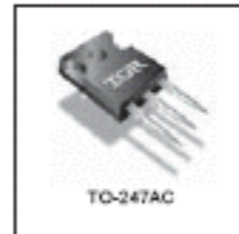

Absolute Maximum Ratings

Parameter	Max.	Units
V_{CES}	600	V
$I_C @ T_C = 25^\circ C$	75	A
$I_C @ T_C = 100^\circ C$	40	
I_{CM}	300	
I_{CM}	300	
V_{GE}	± 20	V
E_{ASW}	200	mJ
$P_D @ T_C = 25^\circ C$	520	W
$P_D @ T_C = 100^\circ C$	210	
T_J	-55 to +150	°C
T_{STG}		
	300 (0.083 in. (1.6mm) from case)	
	10 lbf-in (1.1N-m)	

Thermal Resistance

Parameter	Typ.	Max.	Units
$R_{\theta JC}$	---	0.24	°C/W
$R_{\theta CS}$	0.24	---	
$R_{\theta JA}$	---	40	
Wt	6 (0.21)	---	

www.inf.com

1

042802

International IR Rectifier

PD 9.14670

IRG4PC40UD

INSULATED GATE BIPOLAR TRANSISTOR WITH UltraFast CoPack IGBT
ULTRAFAST SOFT RECOVERY DIODE

Features

- UltraFast: Optimized for high operating frequencies 8-40 kHz in hard switching, >200 kHz in resonant mode
- Generation 4 IGBT design provides tighter parameter distribution and higher efficiency than Generation 3
- IGBT co-packaged with HEXFRED™ ultrafast, ultra-soft-recovery anti-parallel diodes for use in bridge configurations
- Industry standard TO-247AC package

Benefits

- Generation -4 IGBT's offer highest efficiencies available
- IGBT's optimized for specific application conditions
- HEXFRED diodes optimized for performance with IGBT's. Minimized recovery characteristics require less snubbing
- Designed to be a "drop-in" replacement for equivalent industry-standard Generation 3 IR IGBT's

Absolute Maximum Ratings

Parameter	Max.	Units
V_{CES}	600	V
$I_C @ T_C = 25^\circ C$	40	A
$I_C @ T_C = 100^\circ C$	20	
I_{CM}	160	
I_{CM}	160	
$I_F @ T_C = 100^\circ C$	15	A
I_{FM}	160	
V_{GE}	± 20	V
$P_D @ T_C = 25^\circ C$	160	W
$P_D @ T_C = 100^\circ C$	65	
T_J	-55 to +150	°C
T_{STG}		
	300 (0.083 in. (1.6mm) from case)	
	10 lbf-in (1.1 N-m)	

Thermal Resistance

Parameter	Min.	Typ.	Max.	Units
$R_{\theta JC}$	---	---	0.77	°C/W
$R_{\theta CS}$	---	---	1.7	
$R_{\theta JA}$	---	0.24	---	
$R_{\theta JA}$	---	---	40	
Wt	---	6 (0.21)	---	g (oz)

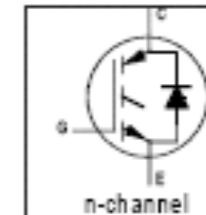

$V_{CES} = 600V$
$V_{CE(sat)} \text{ typ.} = 1.72V$
@ $V_{GE} = 15V, I_C = 20A$

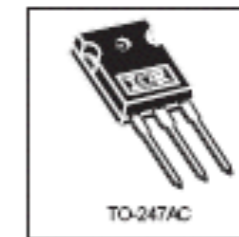

Demonstração

Demo

- Testes de IGBT com multímetro.



BJT x MOSFET x IGBT

	MOSFET	IGBT	BJT
Tipo de comando	Tensão	Tensão	Corrente
Potência do comando	Mínima	Mínima	Grande
Complexidade do comando	Simples	Simples	Média
Densidade de corrente	Elevada em baixas tensões e Baixa em altas tensões	Muito elevada	Média
Perdas de comutação	Muito baixa	Baixa para Média	Média para Alta

Componentes Semicondutores:

- Dimensionamento e especificação de semicondutores.

