

Instituto Federal de Educação, Ciência e Tecnologia de Santa Catarina

Departamento Acadêmico de Eletrônica

Eletrônica de Potência



Semicondutores de Potência

BJT, MOSFET e IGBT

Prof. Clovis Antonio Petry.

Florianópolis, agosto de 2017.

Biografia para Esta Aula

Capítulos 3:



- Transistores de potência.

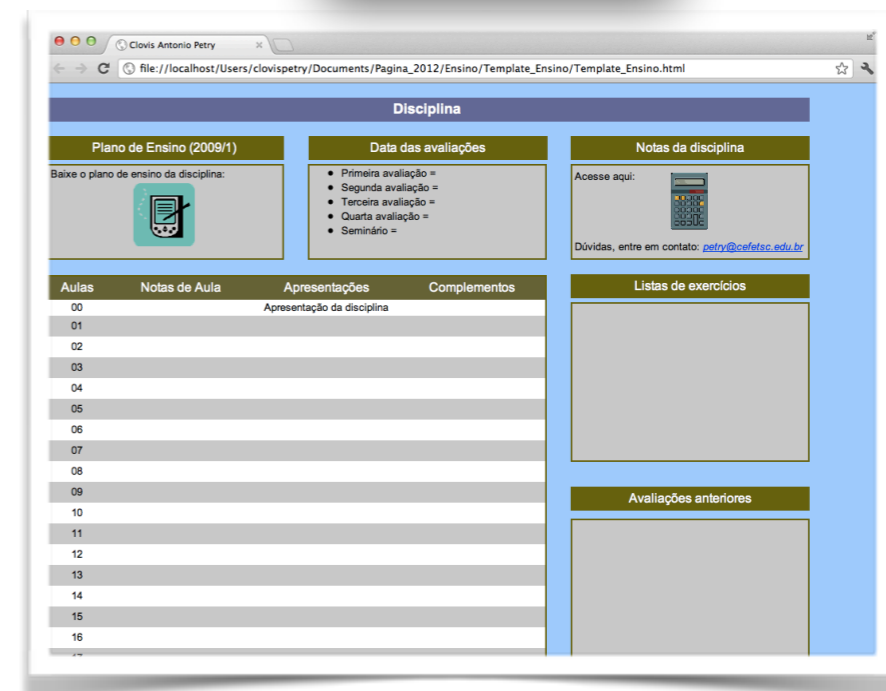

www.ProfessorPetry.com.br

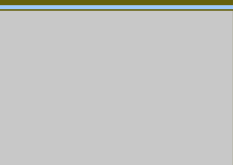
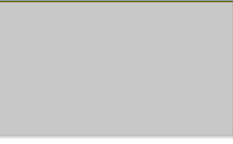

A screenshot of a web page titled "Disciplina" (Discipline). The page is organized into several sections:

- Plano de Ensino (2009/1)**: Baixe o plano de ensino da disciplina: 
- Data das avaliações**:
 - Primeira avaliação =
 - Segunda avaliação =
 - Terceira avaliação =
 - Quarta avaliação =
 - Seminário =
- Notas da disciplina**: Acesse aqui: 
Dúvidas, entre em contato: petry@cefetac.edu.br
- Table with 4 columns**: Aulas, Notas de Aula, Apresentações, Complementos. The table has 17 rows, with the first row containing "00 Apresentação da disciplina".
- Listas de exercícios**: 
- Avaliações anteriores**: 

Semicondutores de potência:

- Semicondutores para eletrônica de potência;
- Revisão de BJT;
- BJT x FET;
- FETs;
- MOSFETs;
- IGBTs.

Semicondutores de Potência

Semicondutores aplicados à eletrônica de potência:

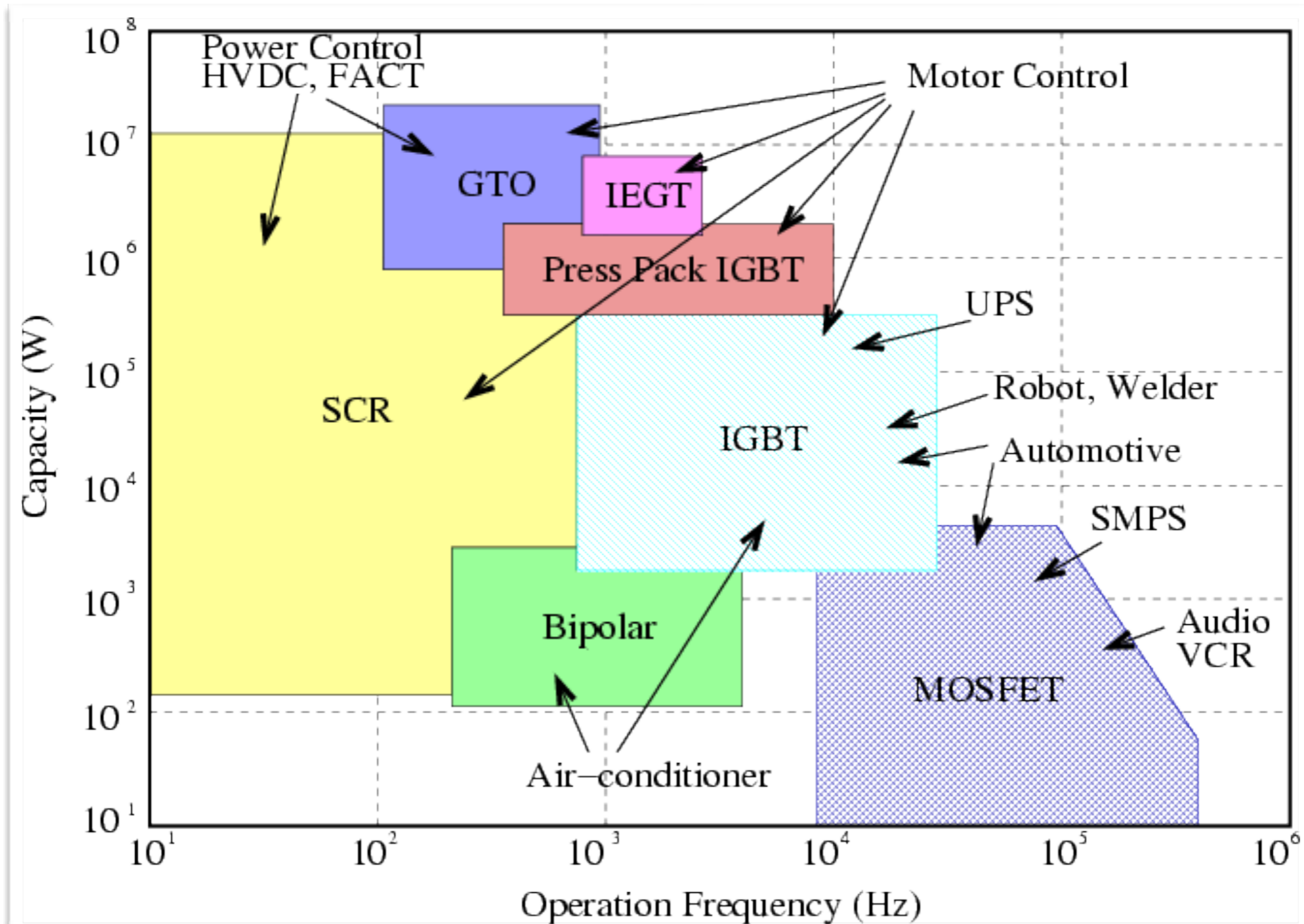

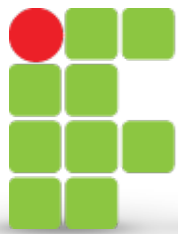

INSTITUTO FEDERAL
SANTA CATARINA

Semicondutores de Potência

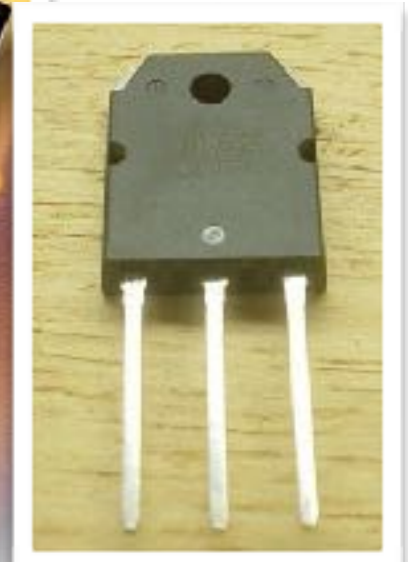

Revisão - BJT

BJT - Transistor bipolar de junção

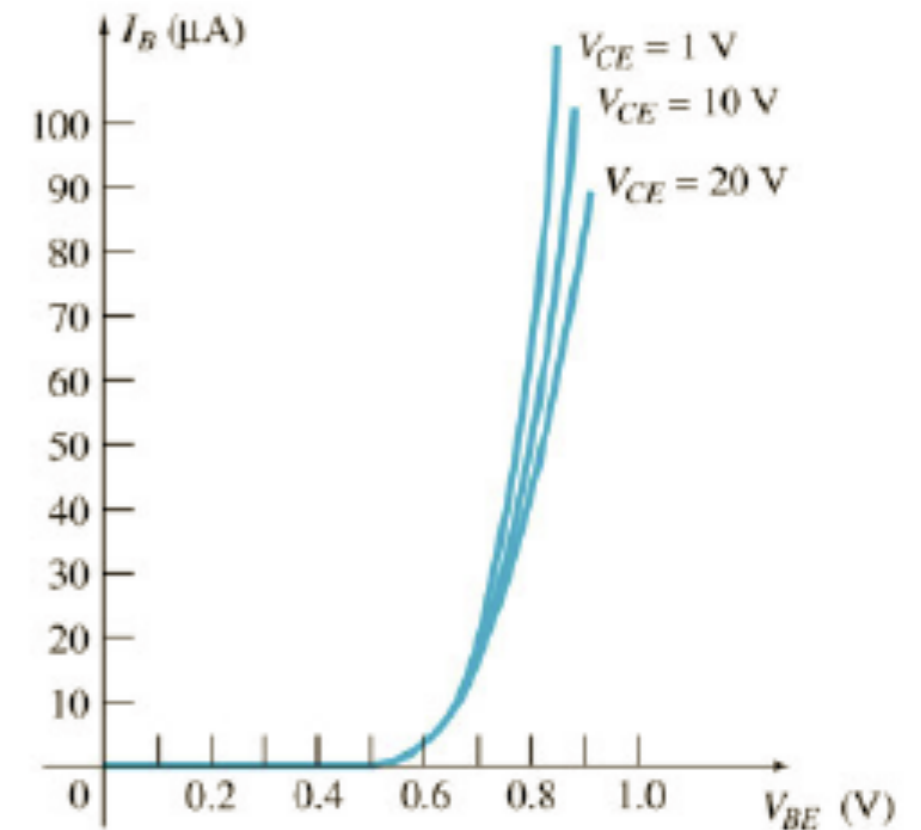
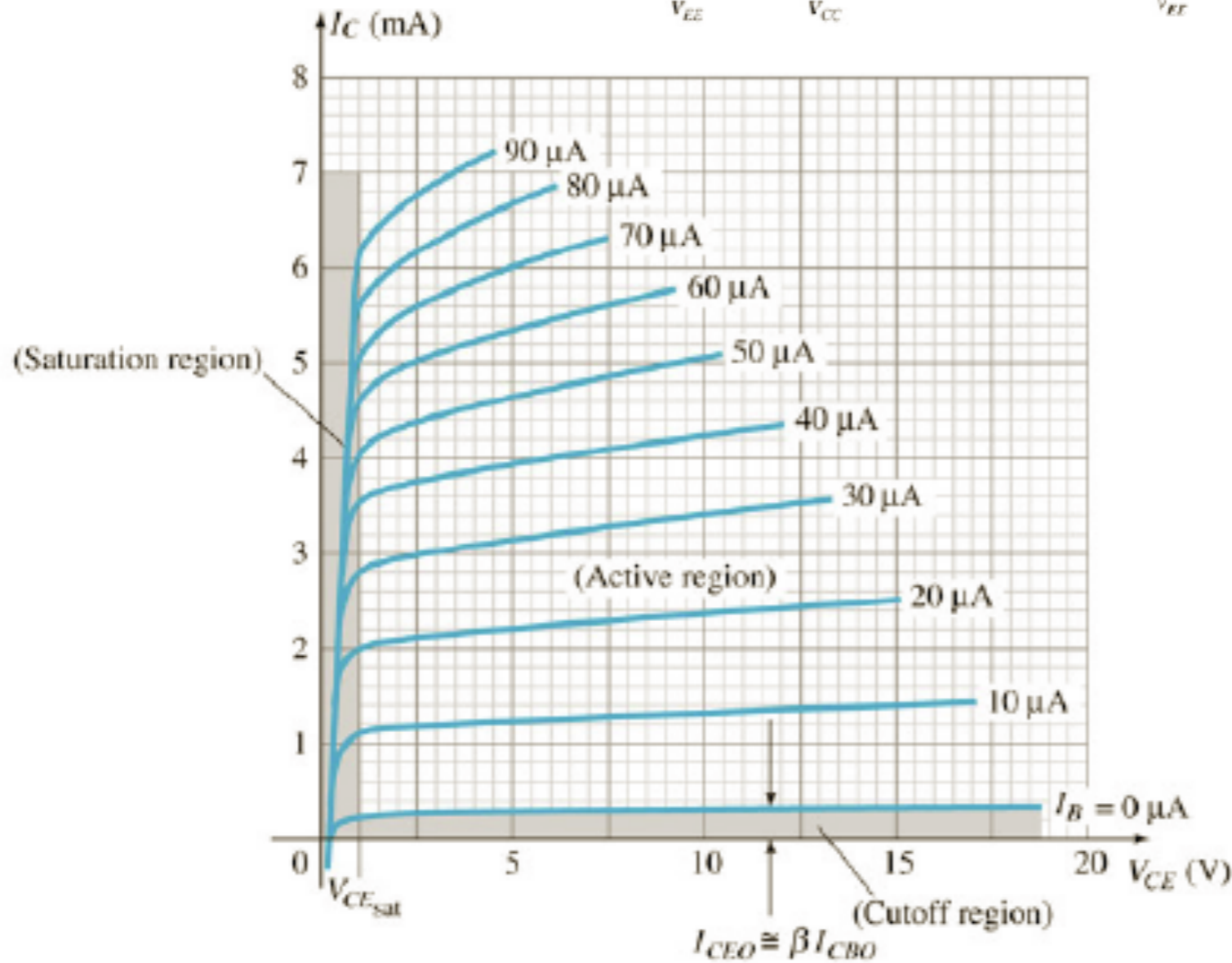
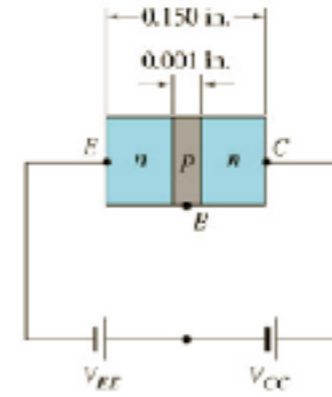
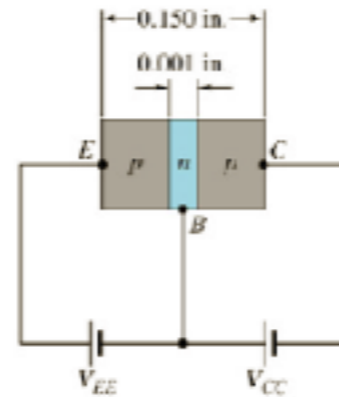

Électronique - Internet Explorer provided by Dell

http://www.univ-lemans.fr/enseignements/physique/02/electro/mnueltro.html

File Edit View Favorites Tools Help

Électronique

Électronique

<p>Oscilloscope cathodique</p> <ul style="list-style-type: none"> Principe Synchronisation Enclenchement en biseau Figures de Lissajous Mesure de déphasage Mesure de fréquences Balayage télévision 	<p>Diodes et transistors</p> <ul style="list-style-type: none"> Pont de Graetz Filtrage (animation) Redressement et filtrage Regulateur a diode Zener Transistor (principe) Transistor en régime variable 	<p>Filtres</p> <ul style="list-style-type: none"> Filtres passifs (exemples) Filtres passifs (général) Filtres en L, T et Pi Filtres en T et T ponts Filtres de Sallen et Kay Filtres de Rauch 	<p>Logique</p> <ul style="list-style-type: none"> Portes logiques Associations de NANDs Associations de NORs Bascules R-S et D Bascules J-K Additionneur binaire
<p>Circuits simples</p> <ul style="list-style-type: none"> Amplificateur opérationnel Diviseur de tension Circuits RC: Filtres Dérivateur Intégrateur Circuits R, L, C série et // Relaxateur a néon Déphaseur passif Déphaseur à AOP Générateur de courant constant Adaptation d'impédances 	<p>Commutation</p> <ul style="list-style-type: none"> Astable Astable à comparateur Monostable Comparateur de Schmitt 	<p>Convertisseurs</p> <ul style="list-style-type: none"> Convertisseur N/A R-2R Convertisseur A/N simple rampe Convertisseur A/N à approximations 	<p>Capteurs</p> <ul style="list-style-type: none"> Thermistance Thermomètre à diode Thermomètre Pt500 Impédance d'un quartz
<p>Divers</p>	<p>Divers</p>		

Internet | Professeur Michel Gu... 100%

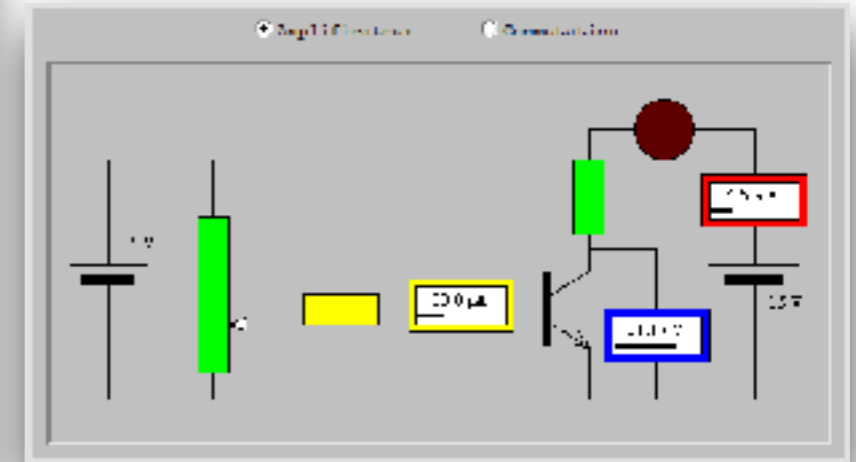

BJT x FET

FET - Transistor de efeito de campo

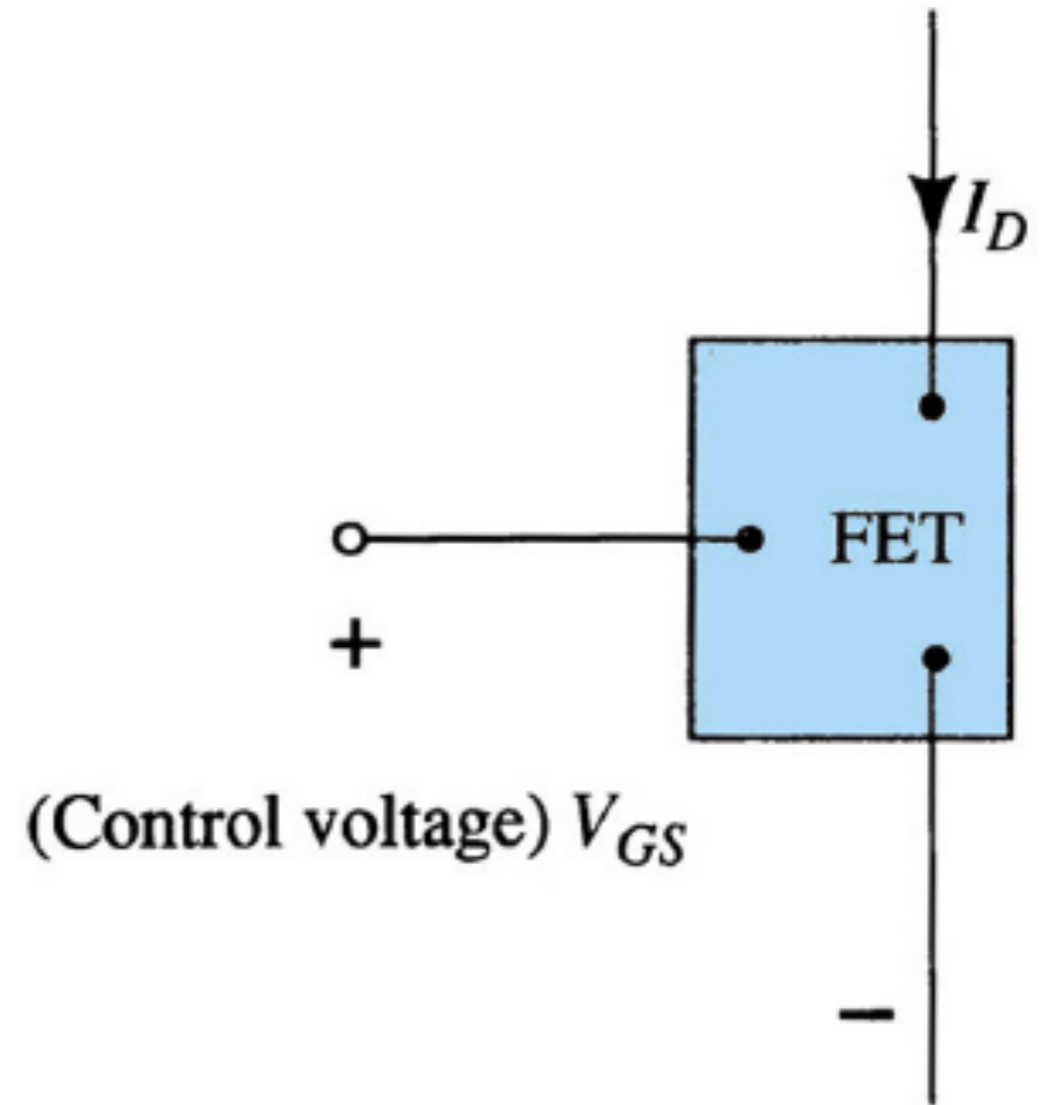
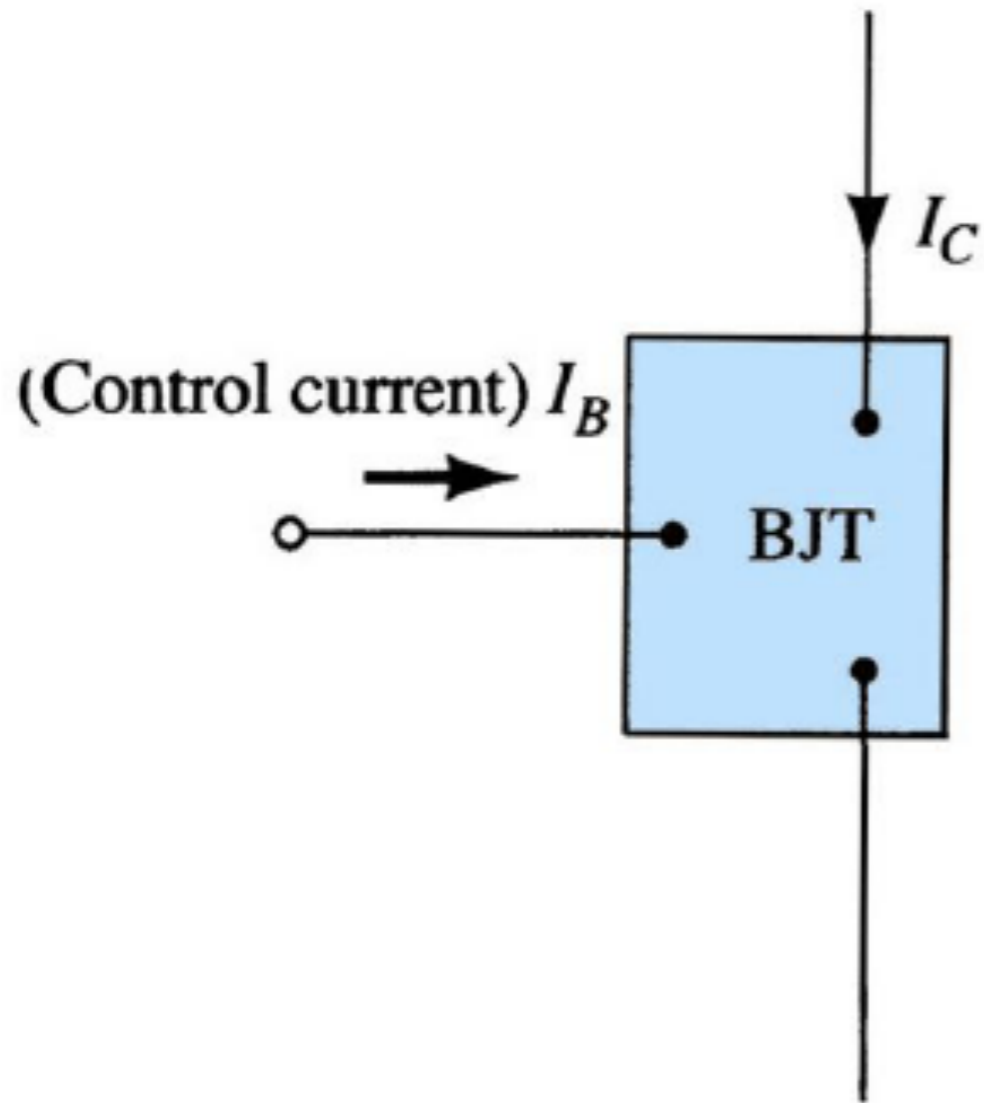

FET

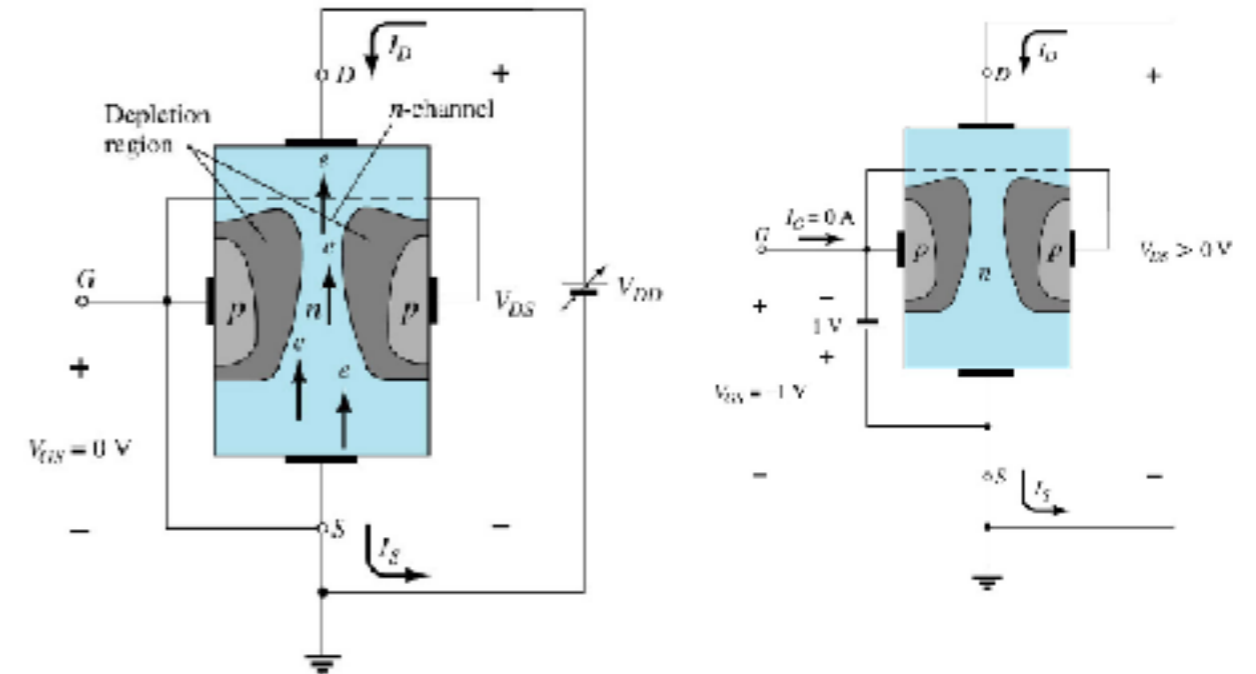
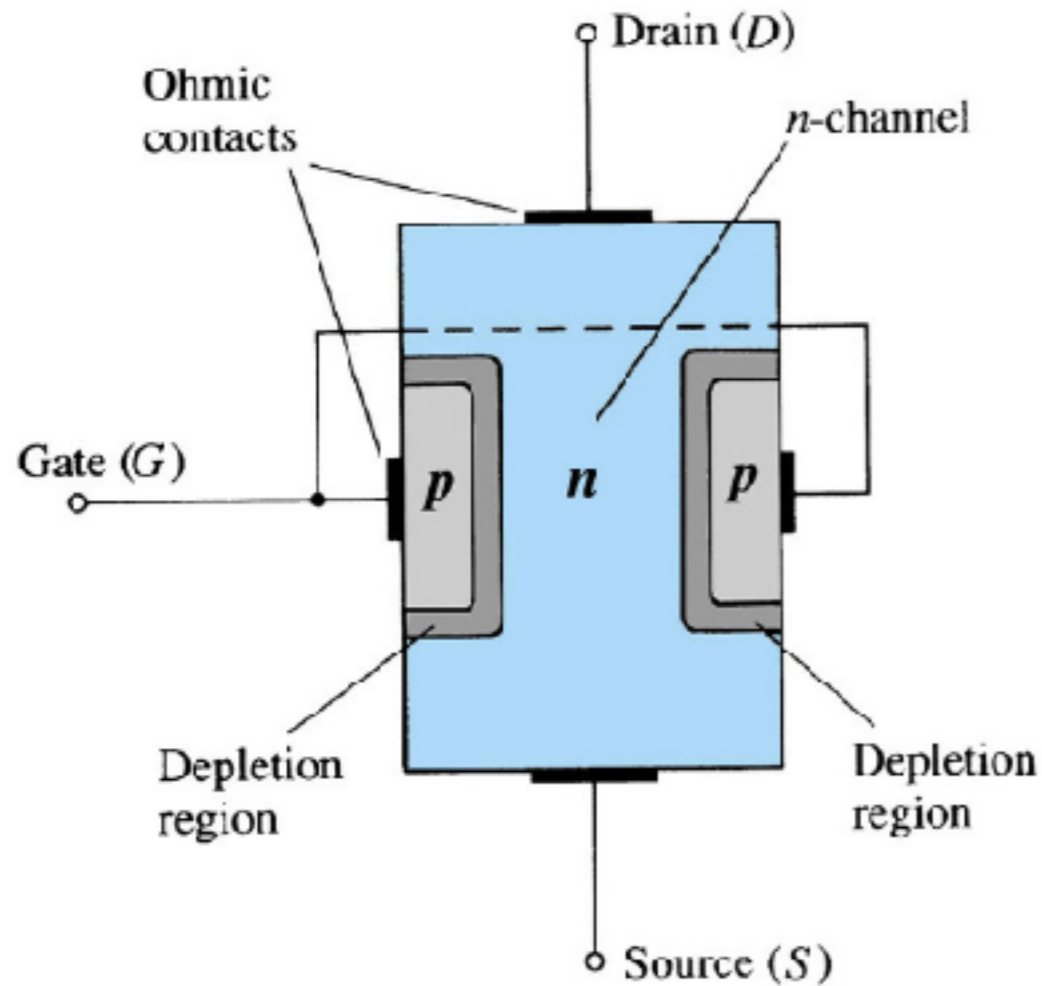

JFET: Operação básica

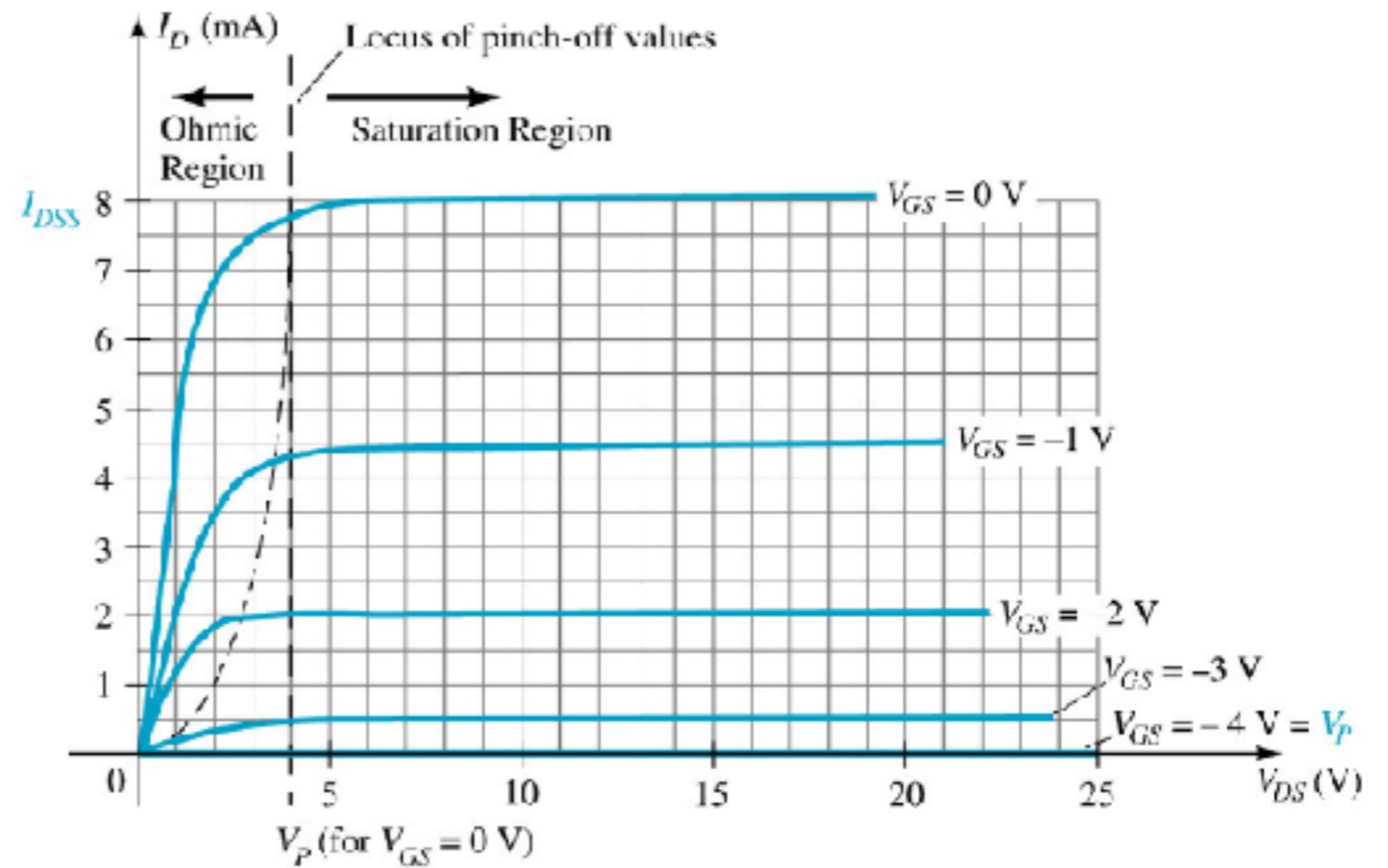



Semiconductor Applet Services - Internet Explorer provided by Dell

http://jas.eng.buffalo.edu/

The Semiconductor Applet Service
(Supported in part by the National Science Foundation)

List of Simulation Applets

- Crystal Structure**
 - Zincblende and Diamond structures (GaAs, Si, etc.). [unicell with a list of material property](#). It gives you the 3D views of the unitcell and the covalent bonds.
 - [Hexagonal Closed Packed structures](#) (ZnS, GaN, SiC, etc.). An interactive 3D view of the crystal unitcell.
 - [Crystal Structure and the 14 Bravais Lattices](#) (java1.3): you can add various Basis atoms, rotate the crystal with one or multiple unitcells for a 3D view. It has many example crystals. You can also view the lattice planes and directions. [Crystal Structure in Java 3D](#) (Java3D plugin maybe needed; see link in page)
- Energy Bands and Charge Carriers**
 - Visualization of [diffusion, drift and recombination](#) of excess minority carriers in a semiconductor.
 - [Indirect recombination via an energy state in the band gap](#). It also introduces the four basic processes in the Shockley-Read-Hall statistics.
 - Energy Band Diagram and k - k Diagram
 - AlGaAs
 - SiGe
- Charge Carriers and Fermi Level** [Semiconductor Statistics]
 - [Fermi Function and Localized Energy States](#) and the Temperature effect.

<http://jas.eng.buffalo.edu/>

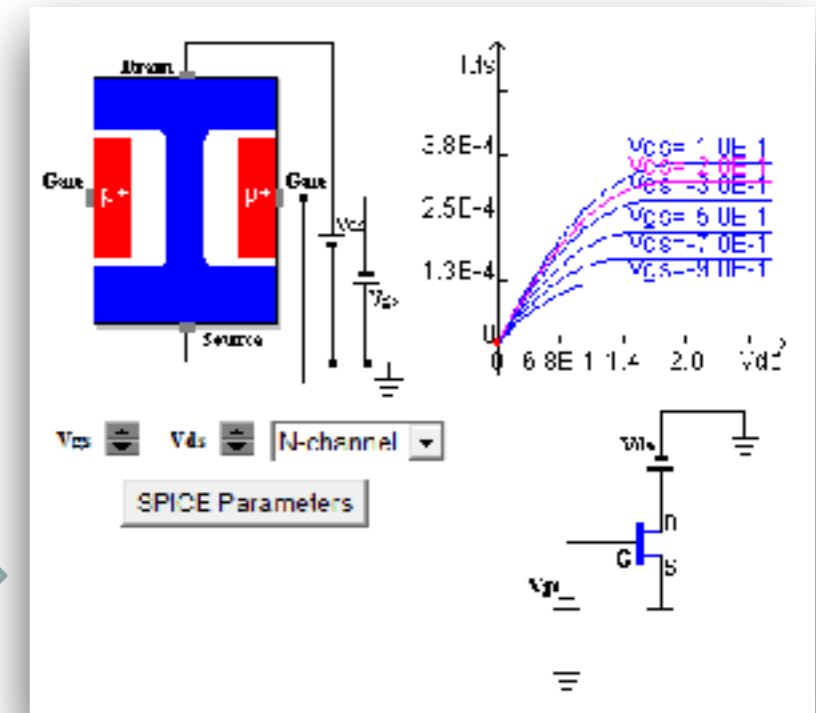
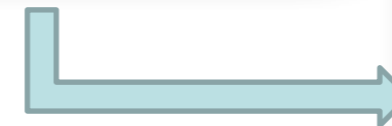

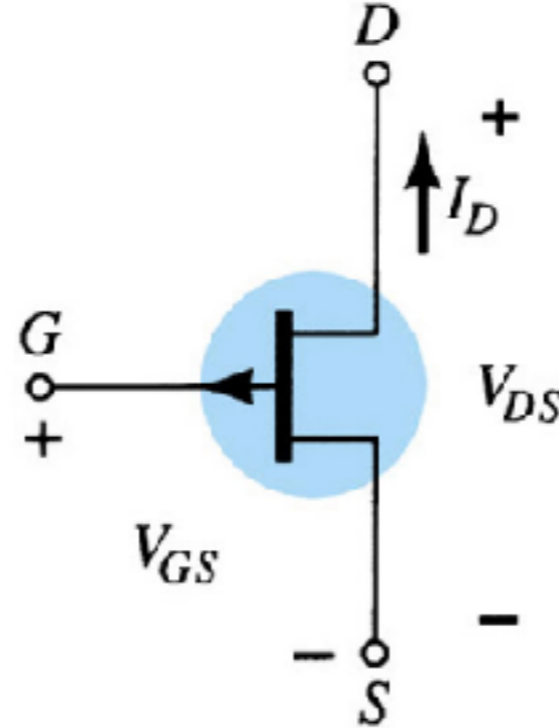
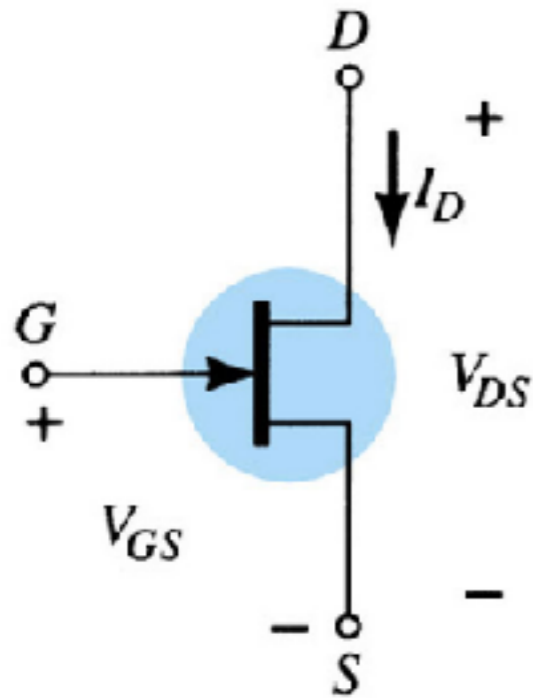

JFET canal n e canal p

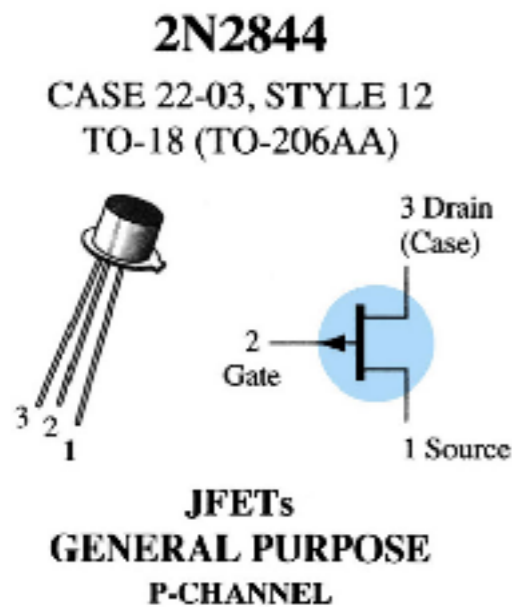
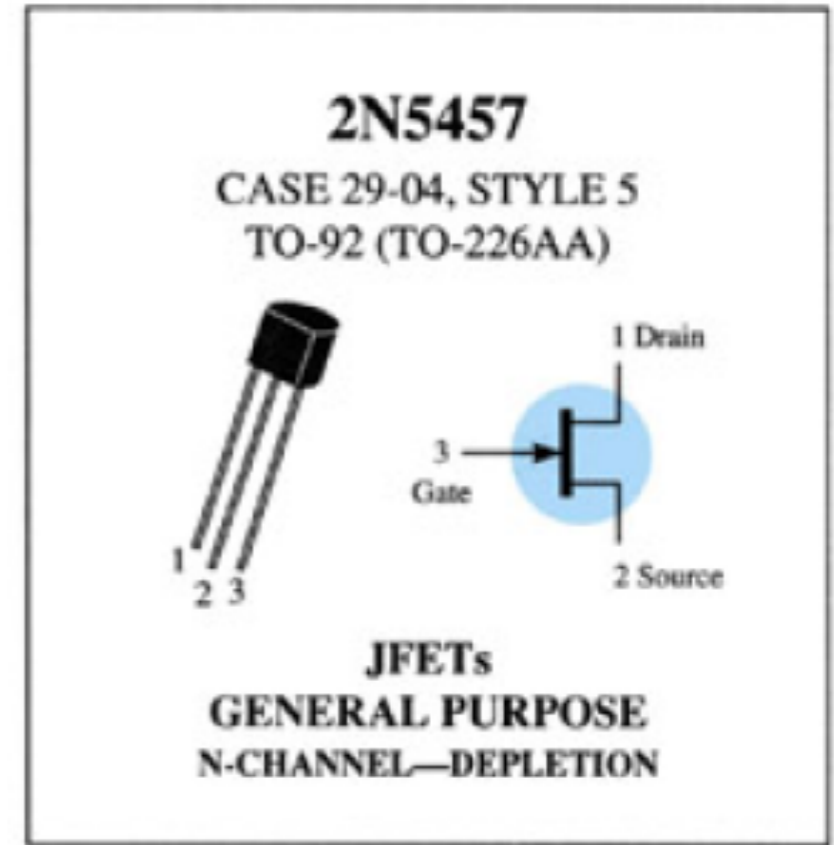

Positivo da Fonte Auxiliar

+ Vaux

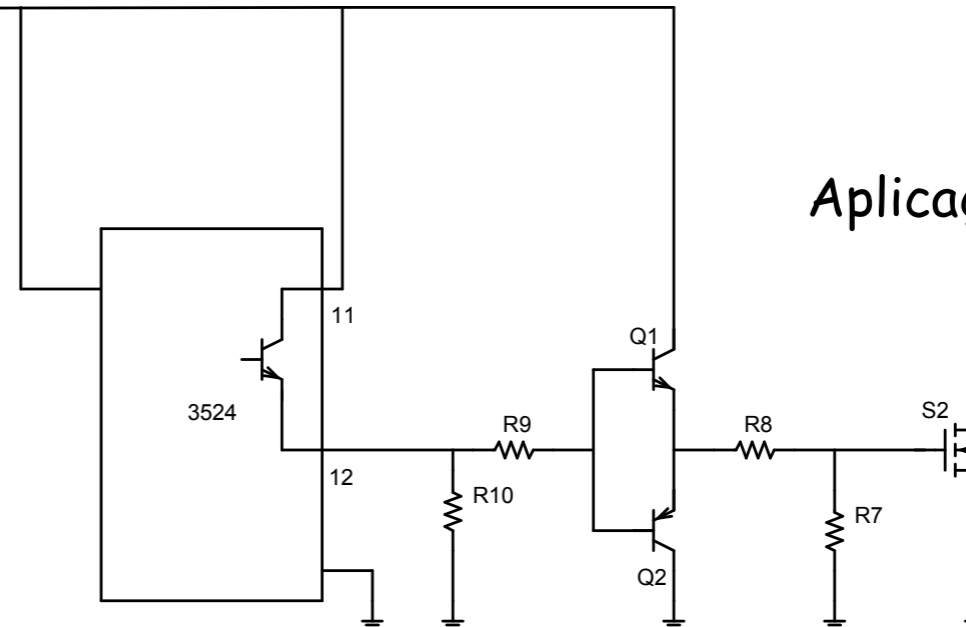

Aplicação do JFET

MOSFET

MOSFET - Metal Oxide Semiconductor Field Effect Transistor

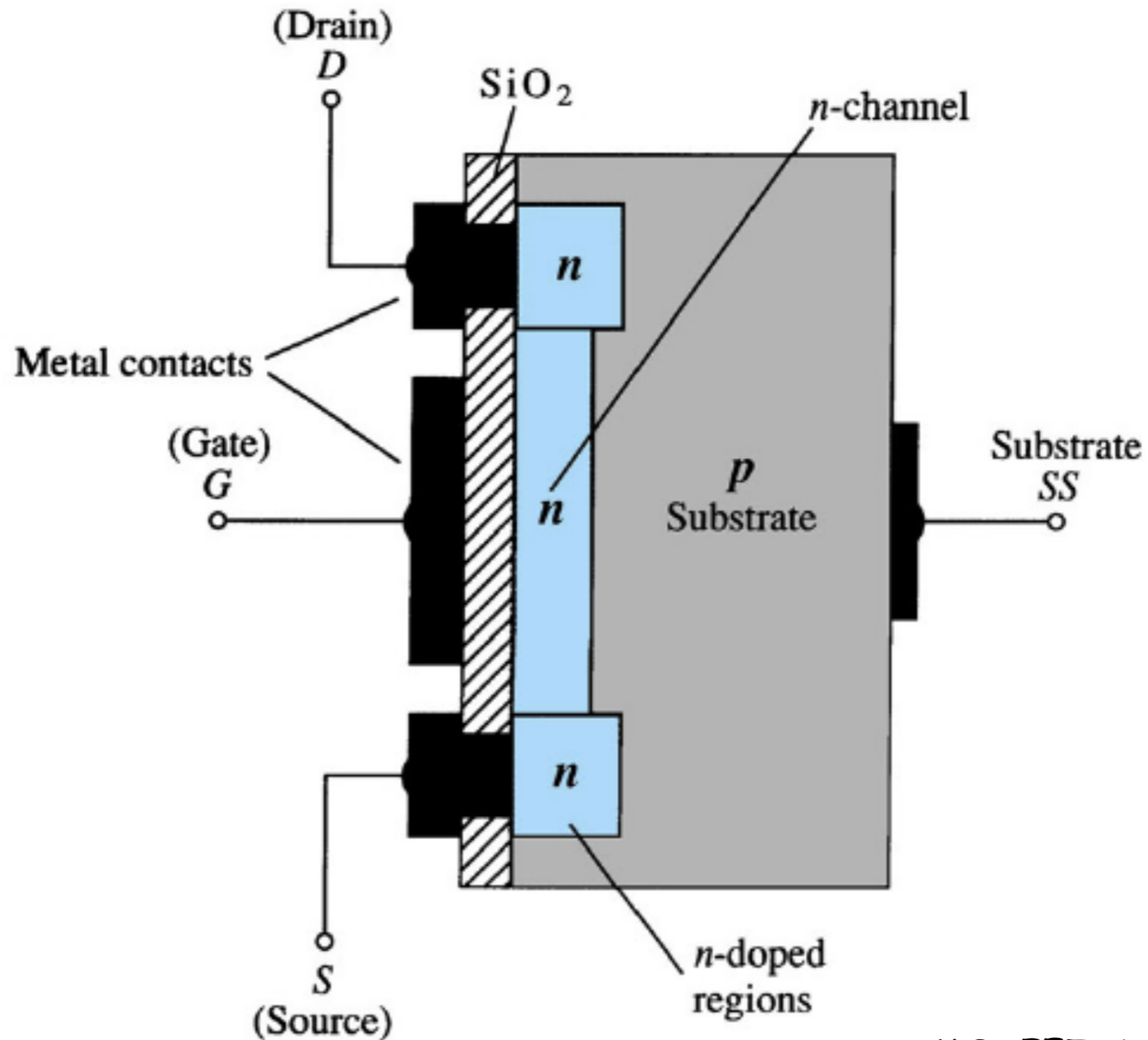

MOSFET tipo Depleção

MOSFET

MOSFET tipo Depleção

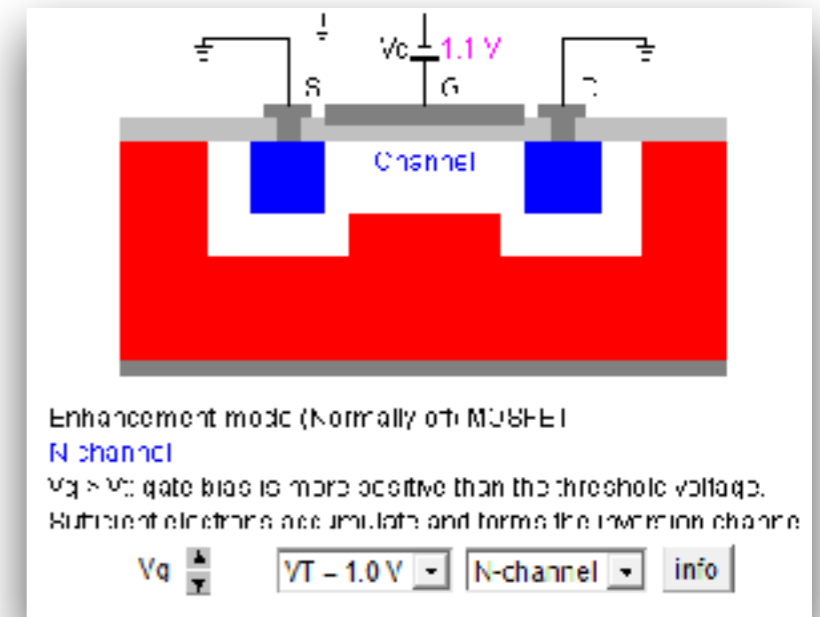
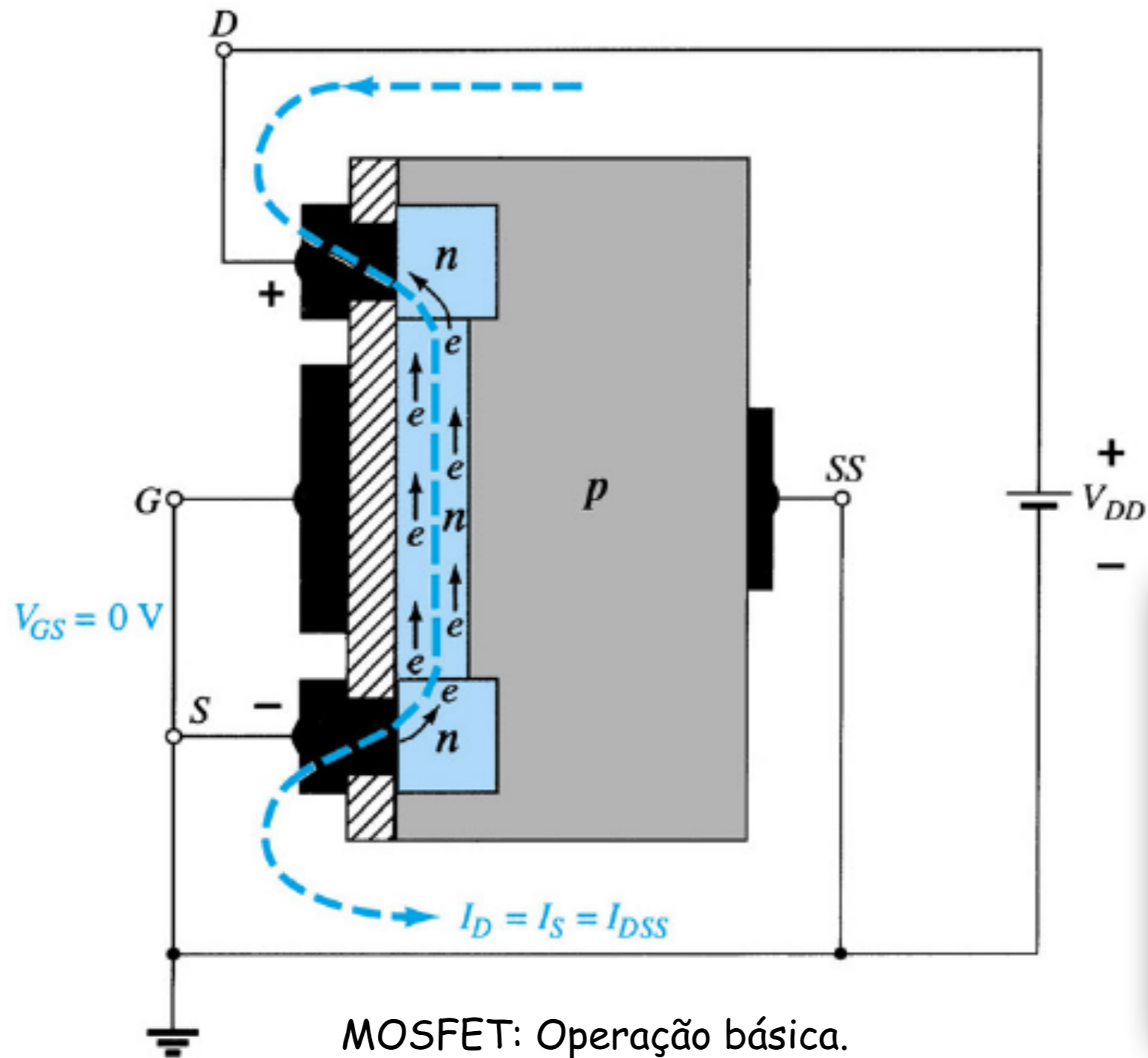

MOSFET tipo Depleção

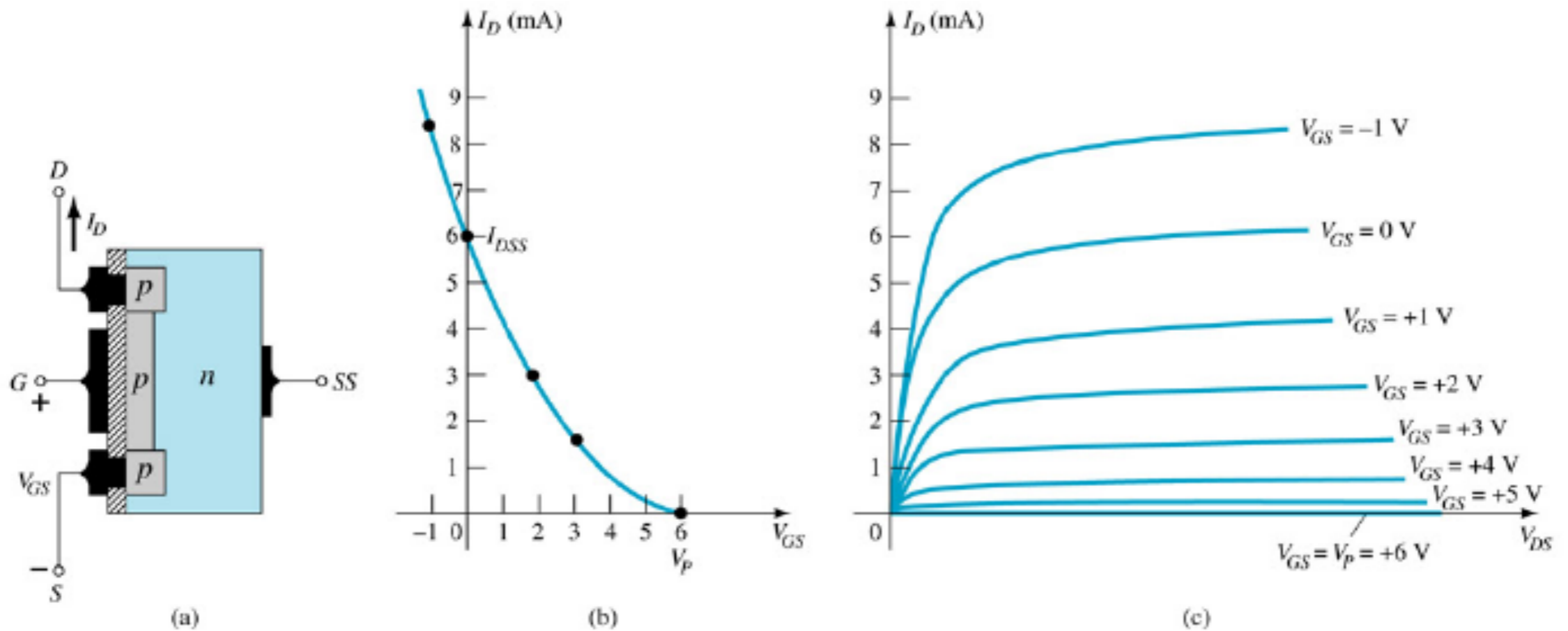

MOSFET: Operação básica.

MOSFET tipo Depleção

n-channel

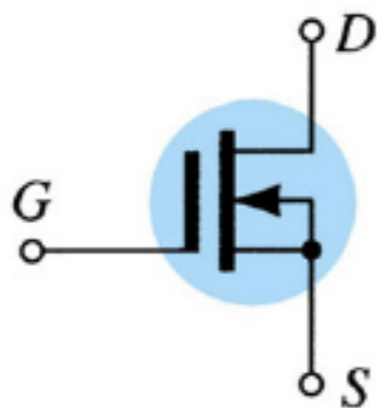
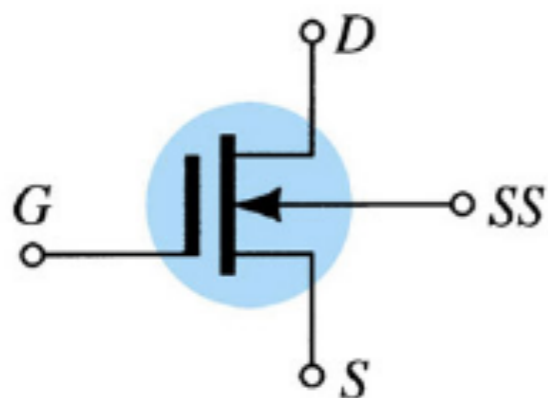

p-channel

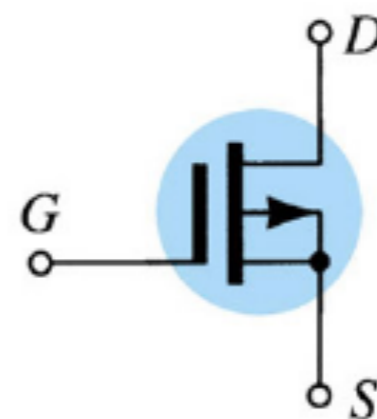
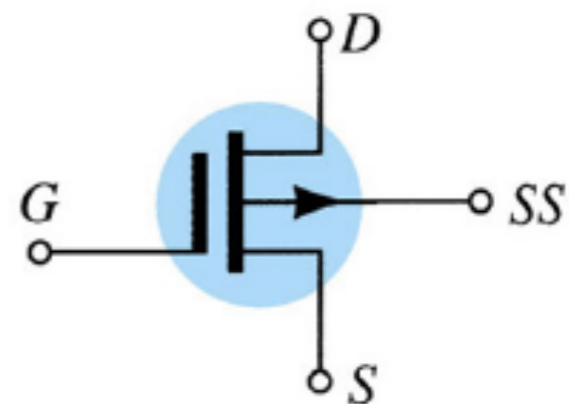

MOSFET tipo Intensificação

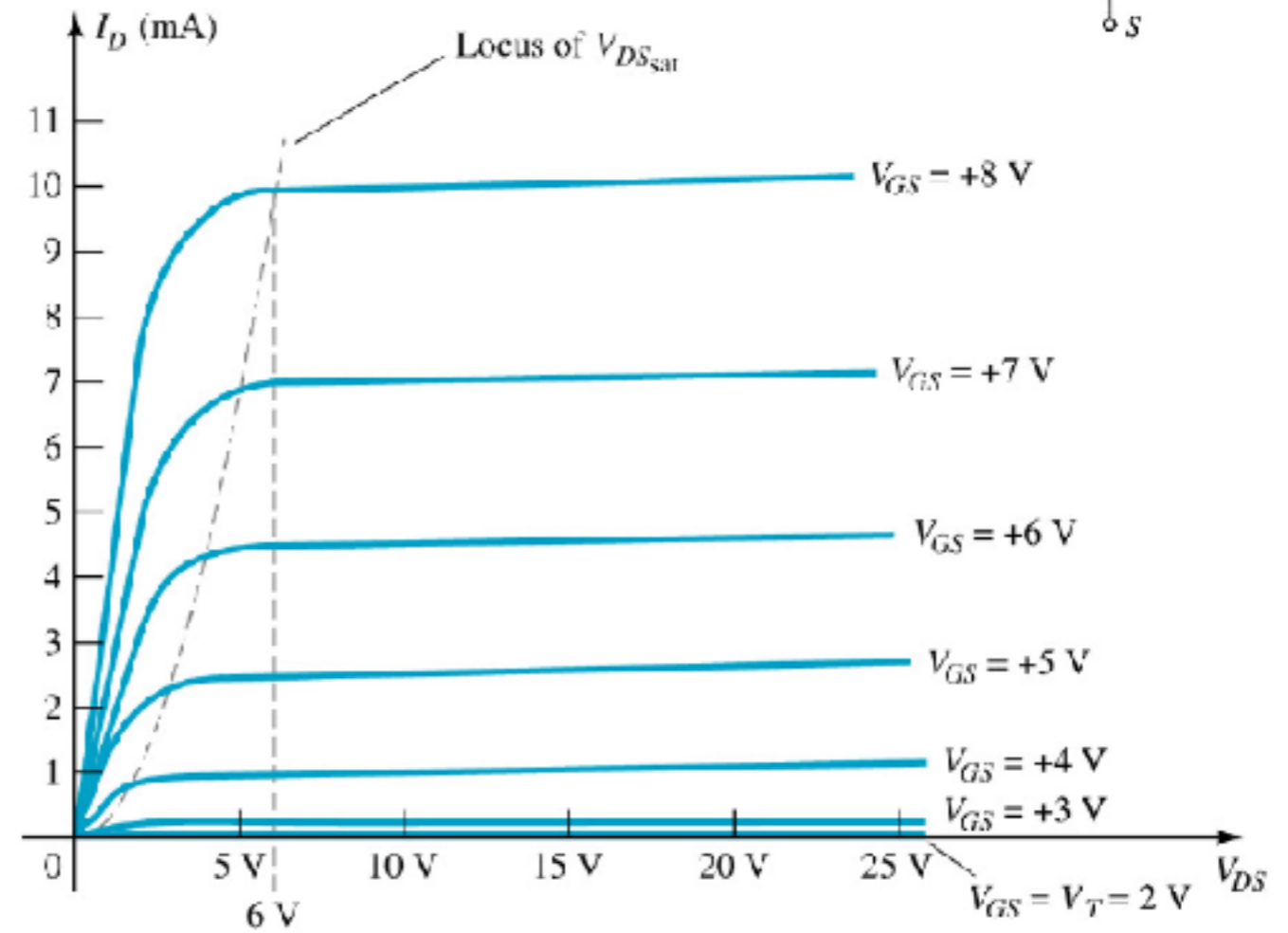
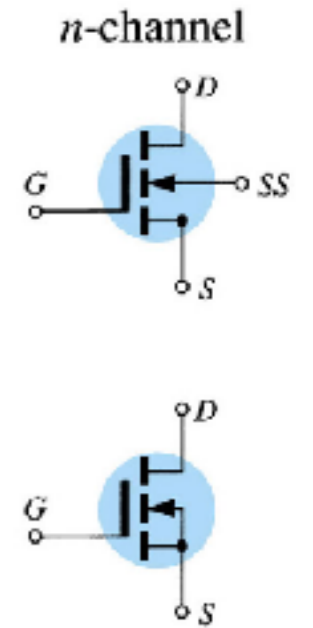
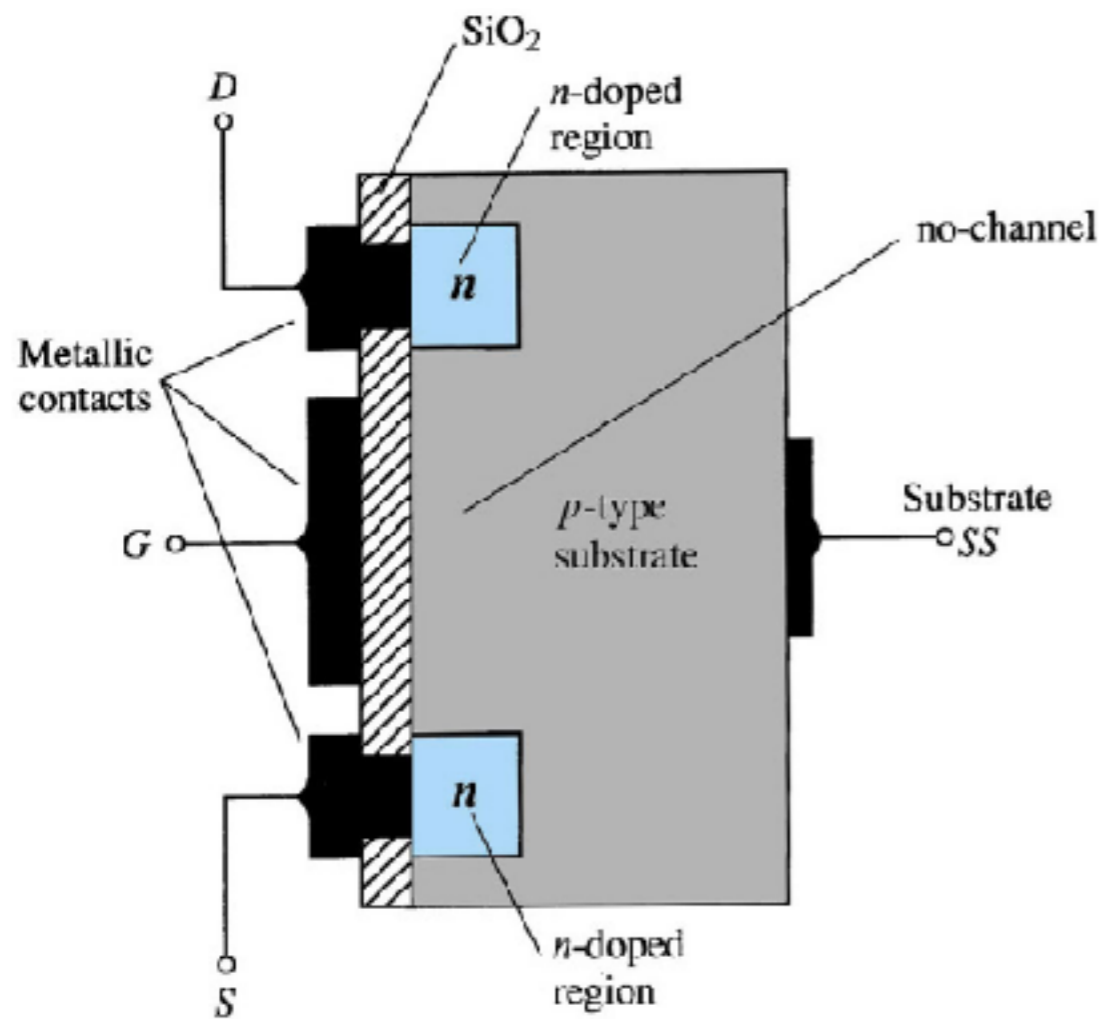

Canal n

MOSFET

MOSFET de Potência

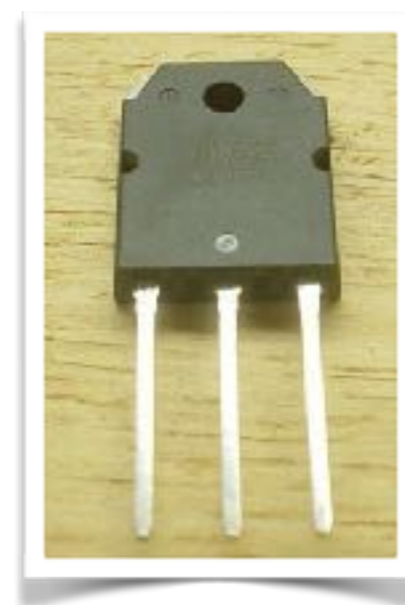
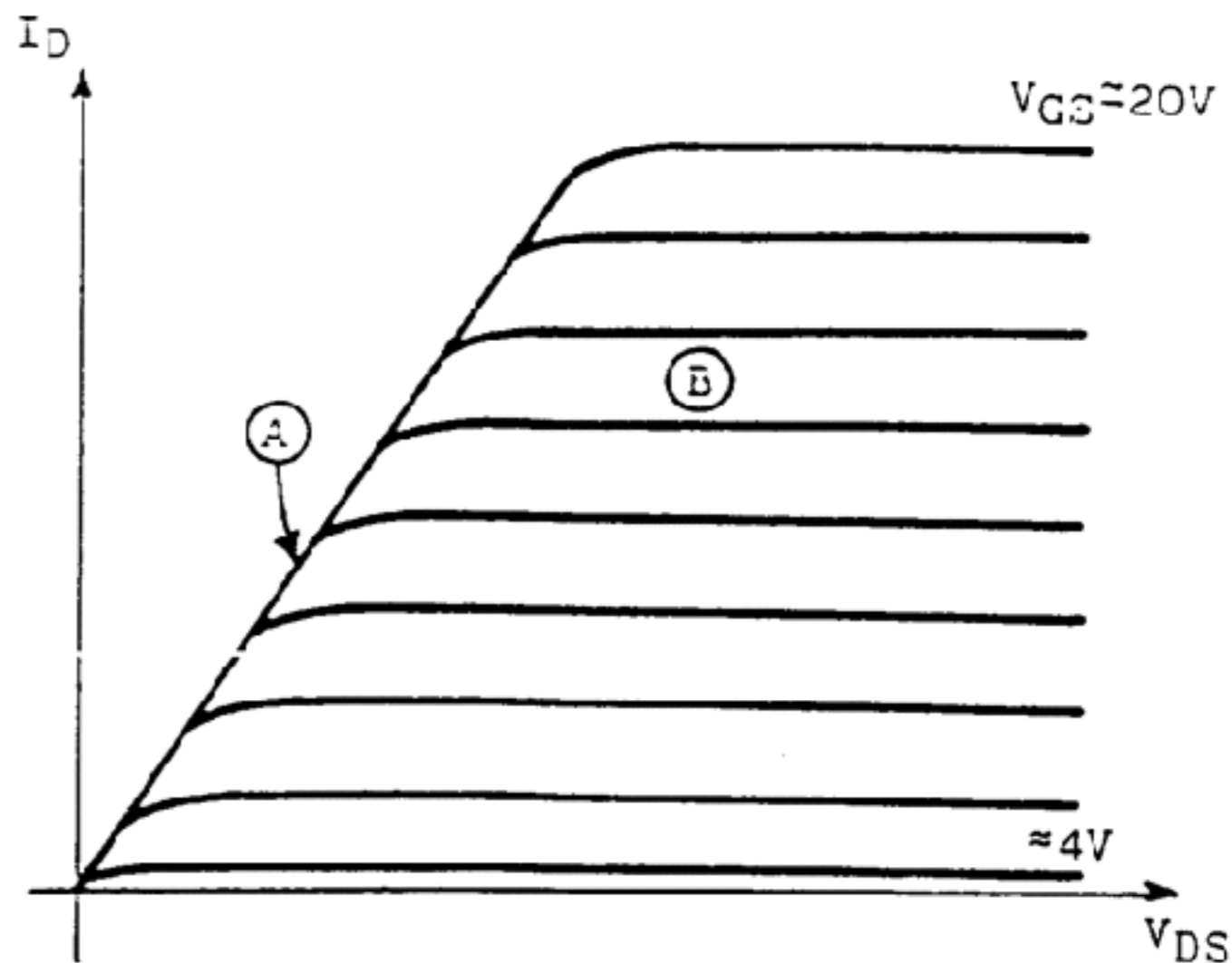
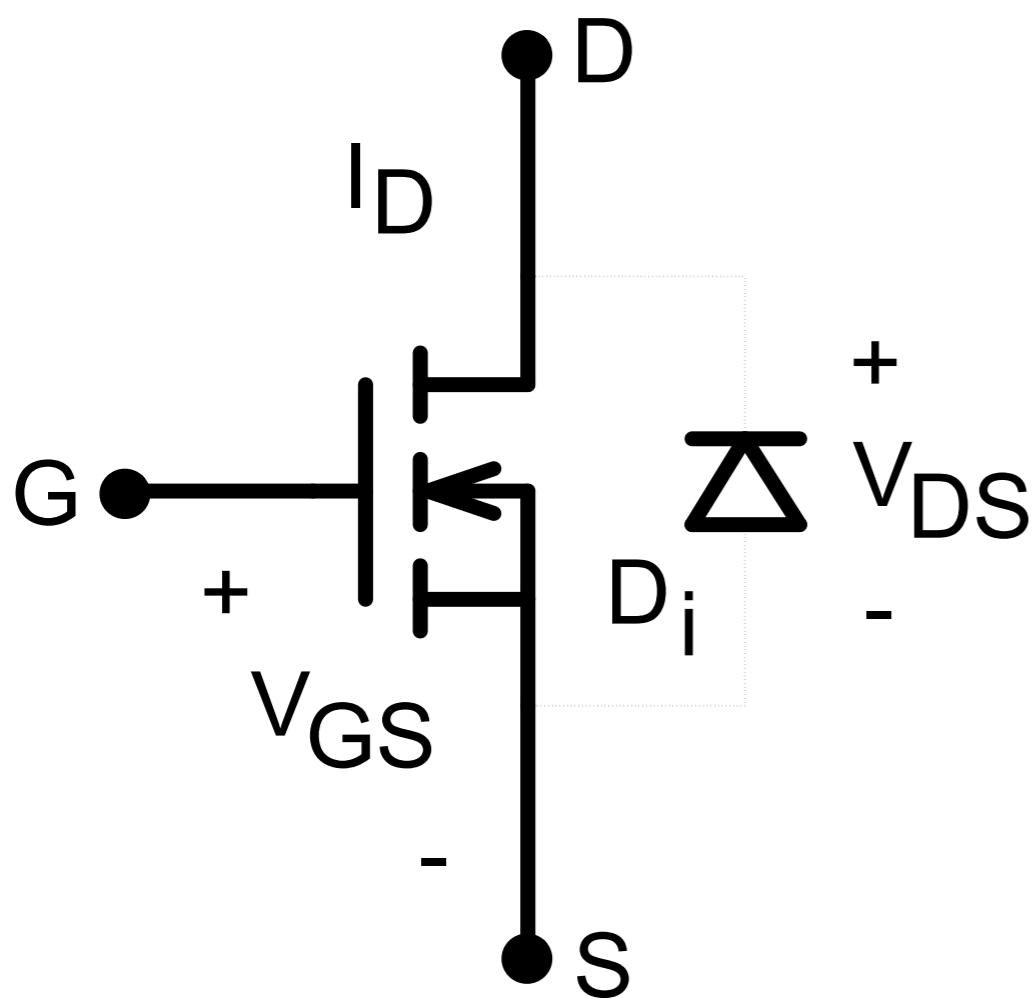

MOSFET de Potência

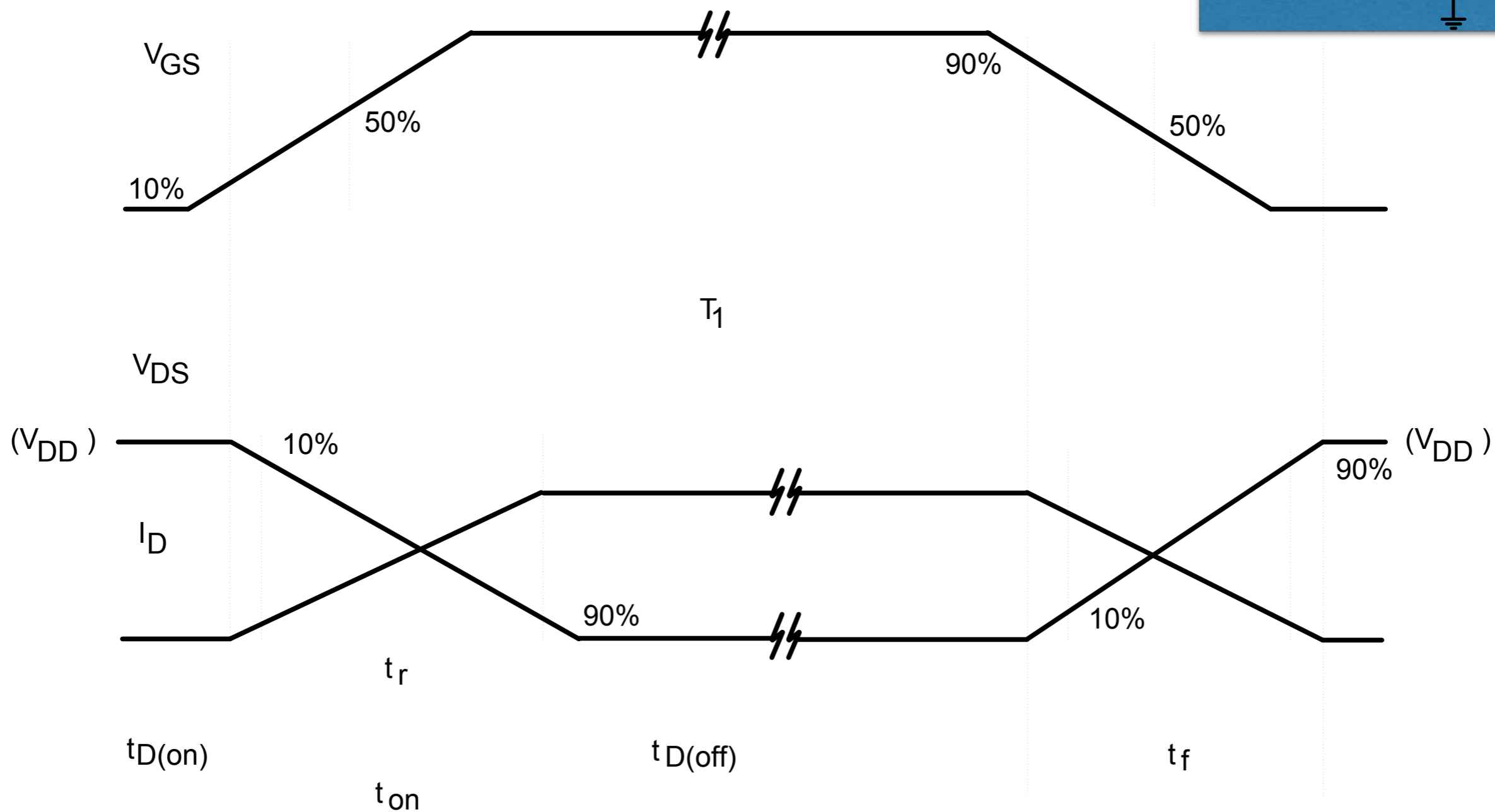
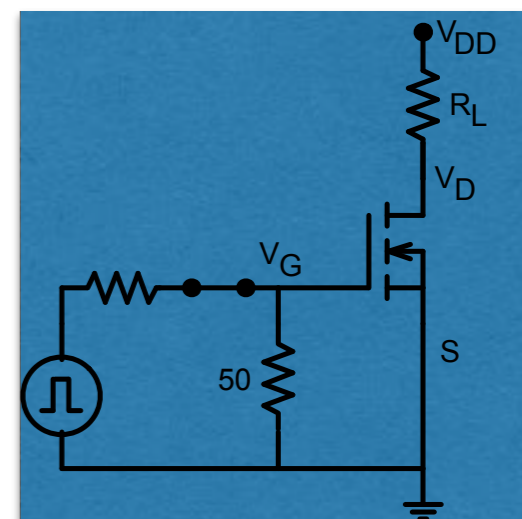

Comutação do MOSFET com carga resistiva

MOSFET de Potência

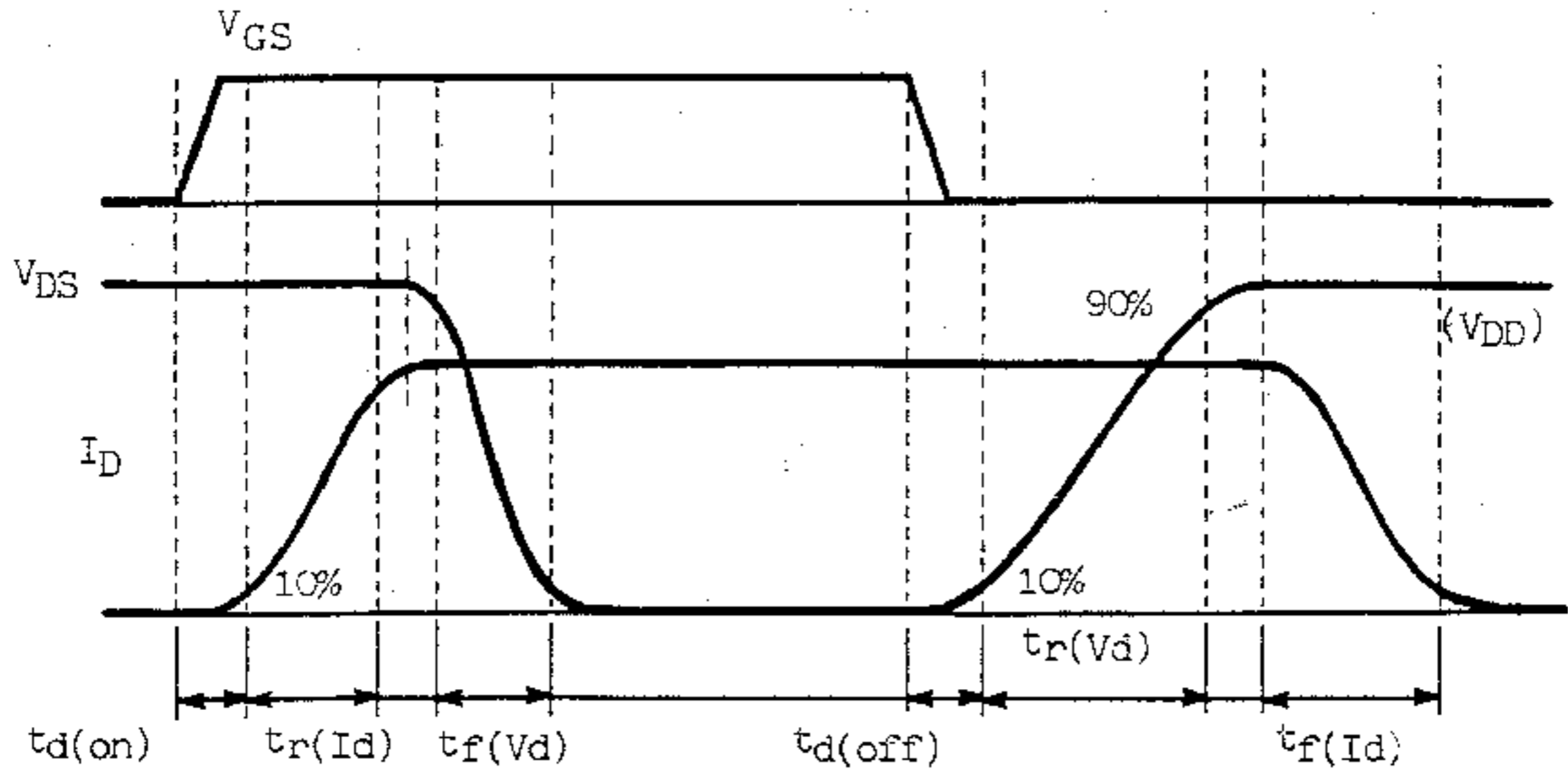
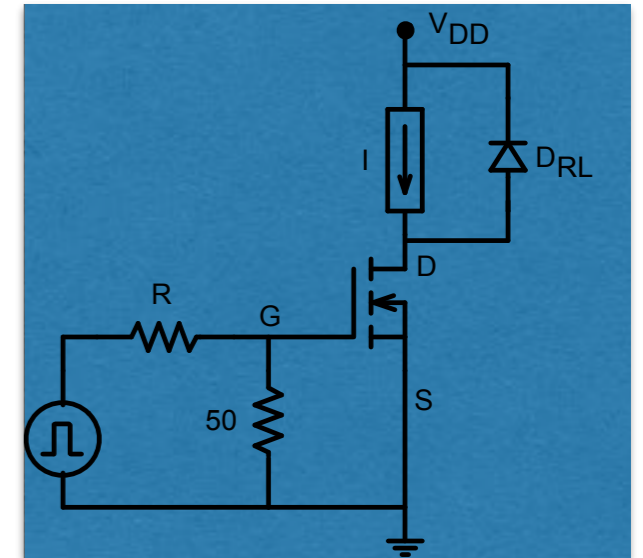

Comutação do MOSFET com carga indutiva

Classificação das perdas:

1. Condução;

$$P_{cond} = \frac{t_{on}}{T} \cdot r_{ds(on)} \cdot i_{d(on)}^2$$

2. Comutação:

- Entrada em condução e bloqueio;

- Onde:

$$t_f \cong t_{on}$$

$$t_r \cong t_{off}$$

Dados de catalogo:

International
IR Rectifier

PD - 94459A

IRFP150V

HEXFET® Power MOSFET

- Advanced Process Technology
- Ultra Low On-Resistance
- Dynamic dv/dt Rating
- 175°C Operating Temperature
- Fast Switching
- Fully Avalanche Rated

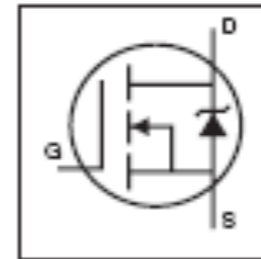

$$V_{DS} = 100V$$

$$R_{DS(on)} = 24m\Omega$$

$$I_D = 47A$$

Description

Advanced HEXFET® Power MOSFETs from International Rectifier utilize advanced processing techniques to achieve extremely low on-resistance per silicon area. This benefit, combined with the fast switching speed and ruggedized device design that HEXFET power MOSFETs are well known for, provides the designer with an extremely efficient and reliable device for use in a wide variety of applications.

The TO-247 package is preferred for commercial-industrial applications where higher power levels preclude the use of TO-220 devices. The TO-247 is similar but superior to the earlier TO-218 package because of its isolated mounting hole.

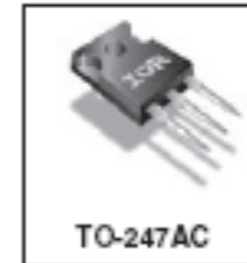

Absolute Maximum Ratings

	Parameter	Max.	Units	
$I_D @ T_C = 25^\circ C$	Continuous Drain Current, $V_{GS} @ 10V$	48	A	
$I_D @ T_C = 100^\circ C$	Continuous Drain Current, $V_{GS} @ 10V$	32		
I_{DM}	Pulsed Drain Current $\text{\textcircled{D}}$	230		
$P_D @ T_C = 25^\circ C$	Power Dissipation	140	W	
	Linear Derating Factor	0.01	W/°C	
V_{GS}	Gate-to-Source Voltage	± 20	V	
I_{AR}	Avalanche Current $\text{\textcircled{D}}$	28	A	
E_{AR}	Repetitive Avalanche Energy $\text{\textcircled{D}}$	20	mJ	
dv/dt	Peak Diode Recovery dv/dt $\text{\textcircled{D}}$	5.8	V/ns	
T_J	Operating Junction and Storage Temperature Range	-55 to +175	°C	
T_{STG}		Soldering Temperature, for 10 seconds		300 (1.8mm from case)
		Mounting torque, 8-32 or M3 screw		10 lb-in (1.1 N-m)

Thermal Resistance

	Parameter	Typ.	Max.	Units
$R_{\theta JC}$	Junction-to-Case	—	1.1	°C/W
$R_{\theta CS}$	Case-to-Sink, Flat, Greased Surface	0.24	—	
$R_{\theta JA}$	Junction-to-Ambient	—	40	

MOSFET

Quando usar MOSFET:

1. Frequências altas (acima de 50 kHz);
2. Tensões muito baixas (< 500 V);
3. Potências baixas (< 1 kW).

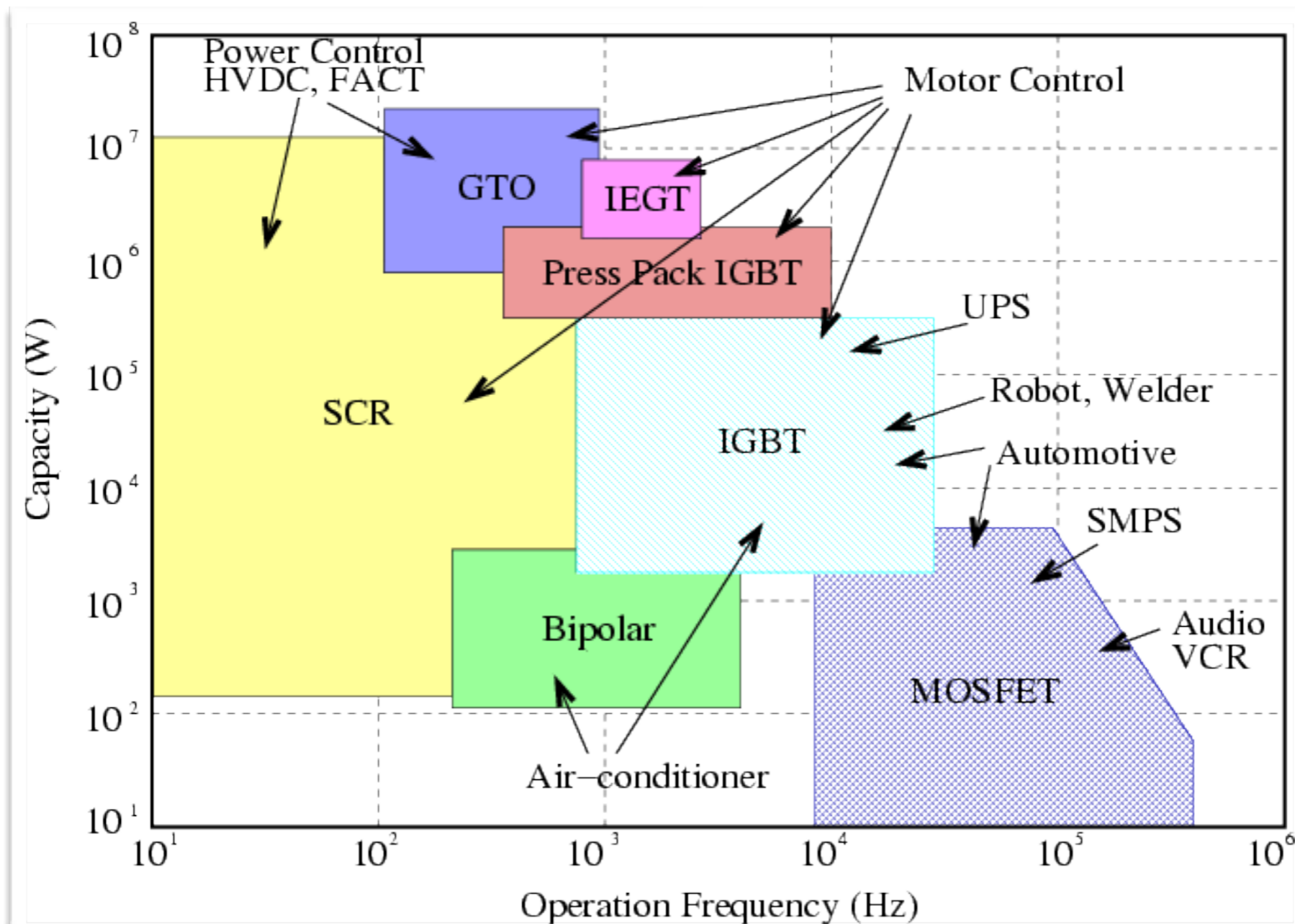

Demonstração

Demo

- Testes de MOSFET com multímetro.



IGBT

IGBT - Insulated Gate Bipolar Transistor

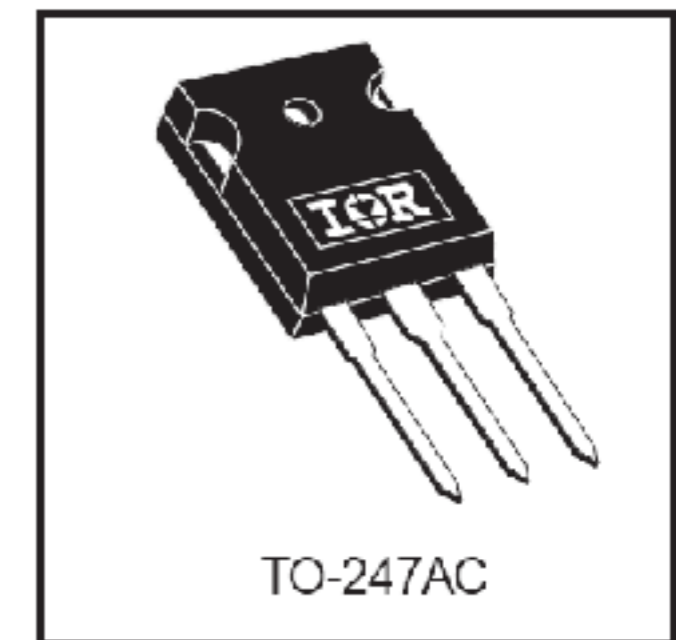
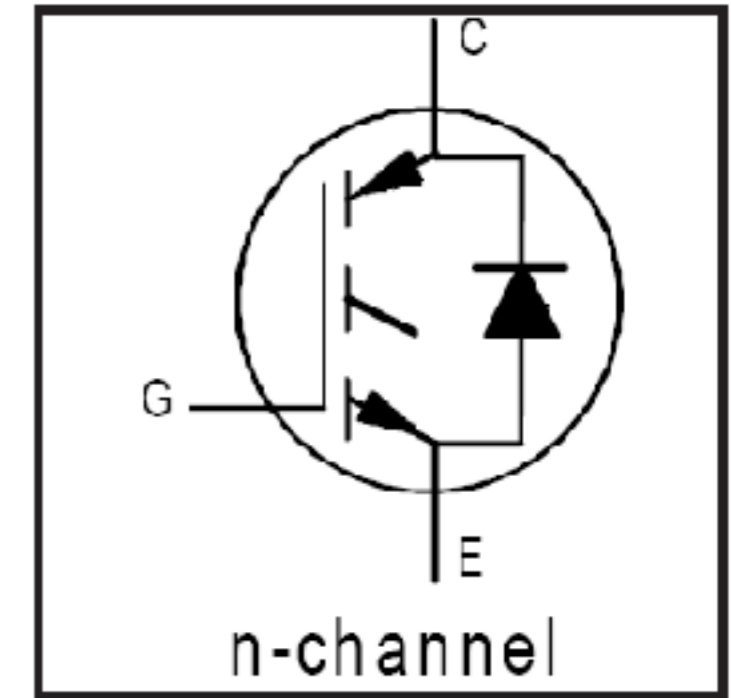
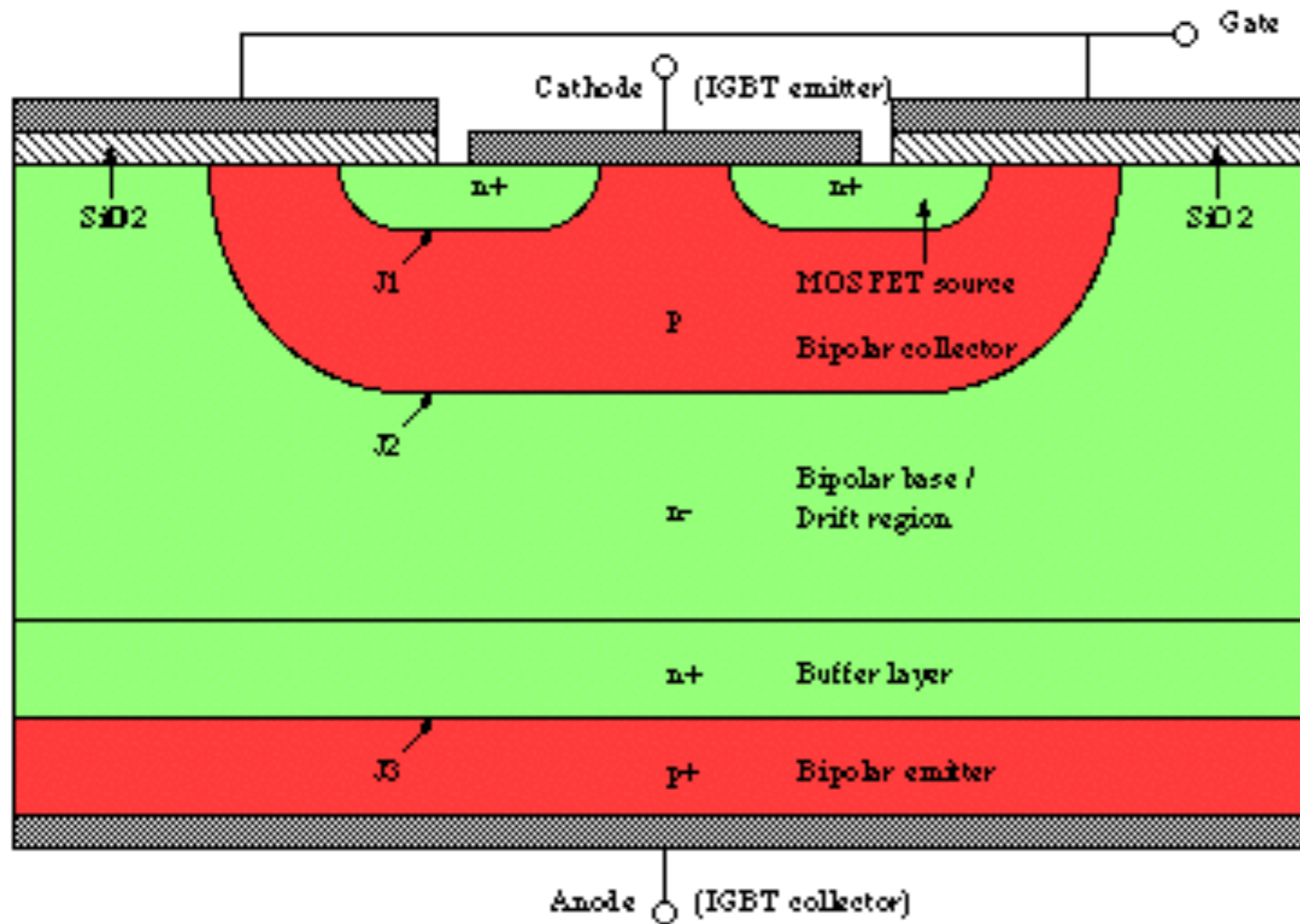

Características de BJT e MOSFET

Classificação das perdas:

1. Condução;

$$P_{cond} = \left(i_C \cdot V_{CEsat} + i_B \cdot V_{BEsat} \right) \cdot t_{on} \cdot f$$

0

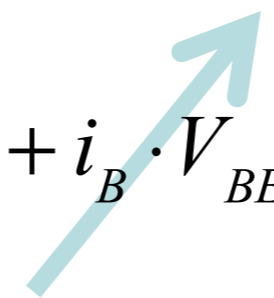

2. Comutação:

- Entrada em condução e bloqueio;

- Onde:

$$P_{com} = \frac{1}{2} (t_r + t_f) \cdot I \cdot E \cdot f$$

Detalhamento do cálculo de perdas



IGBT

Quando usar IGBT:

1. Frequências baixas (menor que 50 kHz);
2. Tensões altas (> 500 V);
3. Potências altas (> 1 kW).



Part	Family	Package	Current	Switching Speed
IGBT0001	IGBT Discrete TO-247AG	Discrete	ULTRAFAST 4-20 kHz	
IGBT0001	IGBT Discrete TO-247AG	Discrete	ULTRAFAST 8-60 kHz	
IGBT0001	IGBT Discrete TO-247AG	Discrete	DC-1 MHz (STANDARD)	
IGBT0001	IGBT Discrete TO-247AG	Discrete	ULTRAFAST 0-80 MHz	
IGBT0001	IGBT Discrete TO-247AG	Discrete	WARP 60-150 kHz	
IGBT0001	IGBT Discrete TO-247AG	Discrete	ULTRAFAST 10-30 kHz	
IGBT0001	IGBT Discrete TO-247AG	Discrete	ULTRAFAST 10-30 kHz	
IGBT0001	IGBT Discrete TO-247AG	Discrete	ULTRAFAST 10-30 kHz	
IGBT0001	IGBT Discrete TO-247AG	Discrete	Low-Voltage	
IGBT0001	IGBT Discrete TO-247AG	Discrete	Low-Voltage	

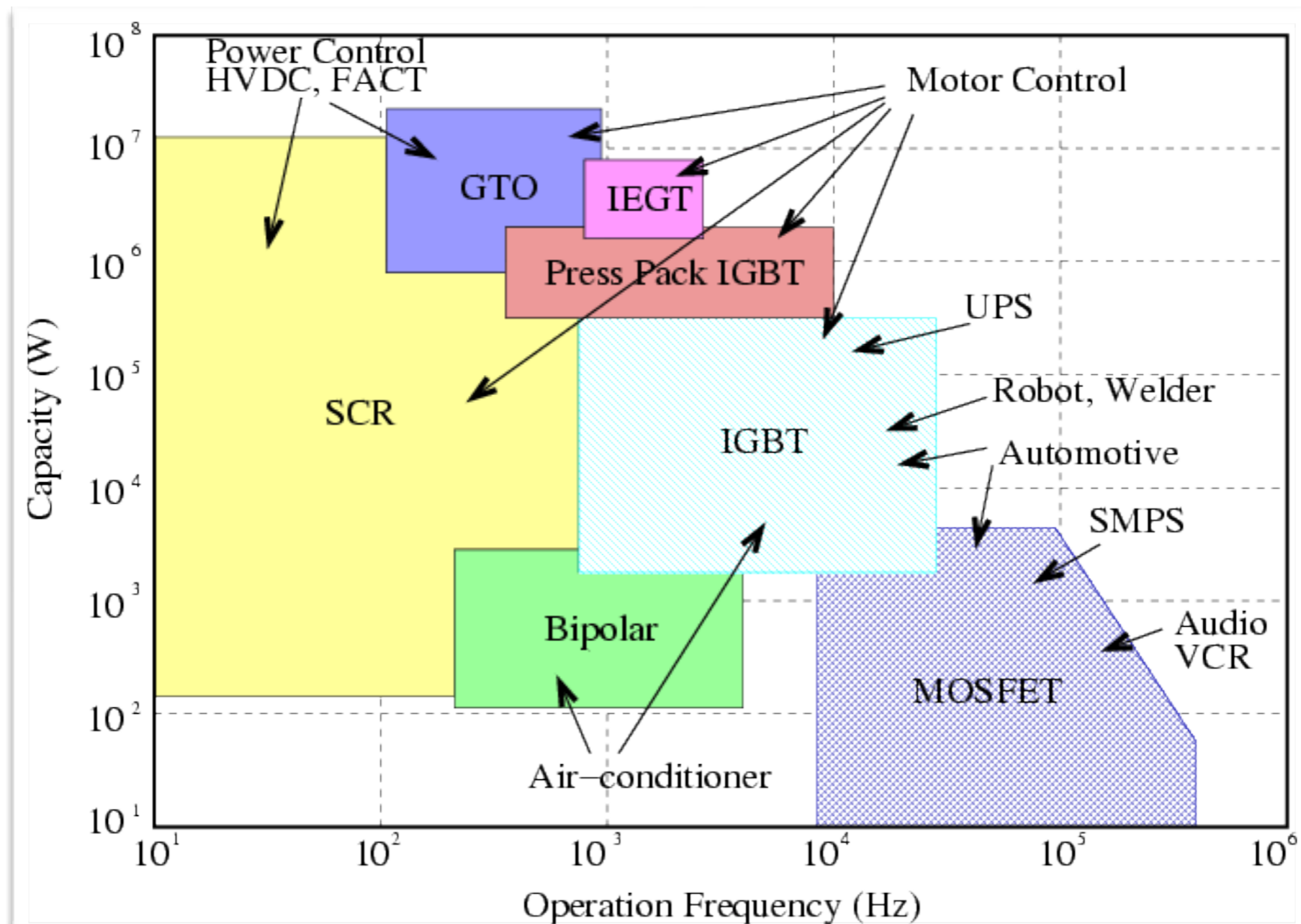

Quando usar IGBT:

1. Freqüências baixas (menor que 50 kHz);
2. Tensões altas (> 500 V);
3. Potências altas (> 1 kW).



www.irf.com

Part	Family	Package	Circuit	Switching Speed	V _{CE(S)} (V)	V _{CE(ON)} (V)	I _{C @ 25C} (A)	I _{C @ 100C} (A)	PD @25C (W)
▲ ▼	▲ ▼	▲ ▼	▲ ▼	▲ ▼	▲ ▼	▲ ▼	▲ ▼	▲ ▼	▲ ▼
IRG4PH30K	IGBT Discretos	TO-247AC	Discrete	ULTRAFAST 4-20 kHz	1200	4.20	20	10	100
IRG4PC20U	IGBT Discretos	TO-247AC	Discrete	ULTRAFAST 8-60 kHz	600	2.1	13	6.5	60
IRG4PC30S	IGBT Discretos	TO-247AC	Discrete	DC-1 kHz (STANDARD)	600	1.60	34	18	100
IRG4PC60U	IGBT Discretos	TO-247AC	Discrete	ULTRAFAST 8-60 kHz	600	2.00	75	40	520
IRG4BC30W	IGBT Discretos	TO-220AB	Discrete	WARP 60-150 kHz	600	2.70	23	12	100
IRGB30B60K	IGBT Discretos	TO-220AB	Discrete	ULTRAFAST 10-30 kHz	600	2.35	78	50	370
IRGB8B60K	IGBT Discretos	TO-220AB	Discrete	ULTRAFAST 10-30 kHz	600	2.2	17	9.0	140
IRGS6B60K	IGBT Discretos	D2-Pak	Discrete	ULTRAFAST 10-30 kHz	600	1.80	13	7	90
IRGS14C40L	IGBT Discretos	D2-Pak	Discrete	Low-Vceon	430	1.40	20	14	125
IRGP4050	IGBT Discretos	TO-247AC	Discrete	Low-Vceon	250	1.90	104	56	330

Encapsulamentos:



www.semikron.com



SEMISTRANS™



SEMiX®



SKiM™



MiniSKiiP®



SEMITOR®

Encapsulamentos:

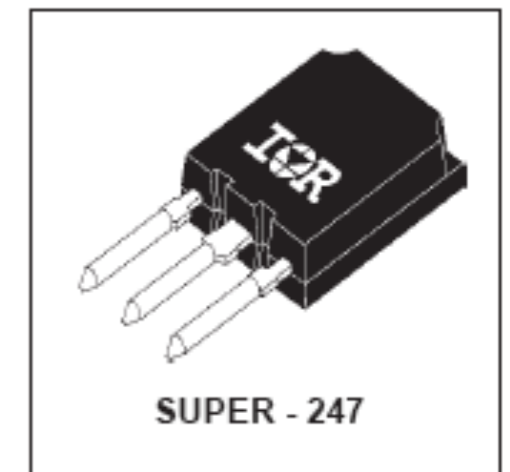
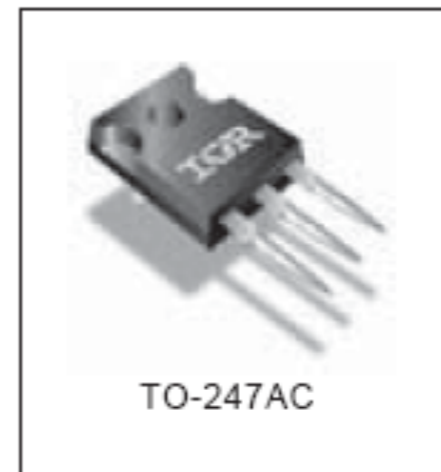
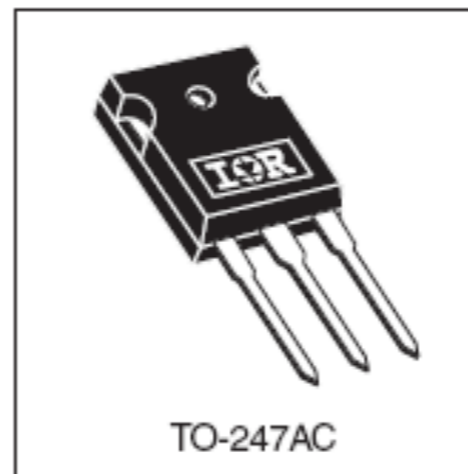
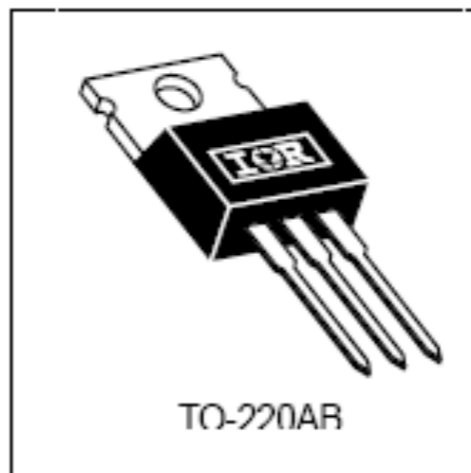
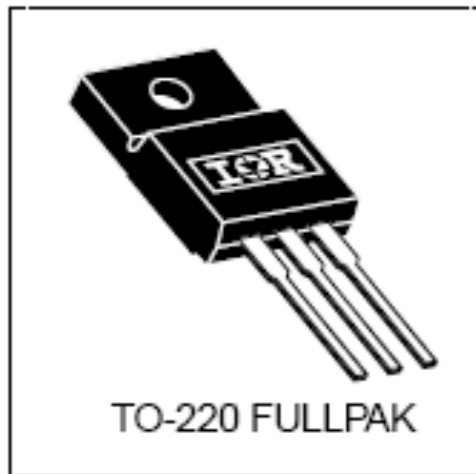
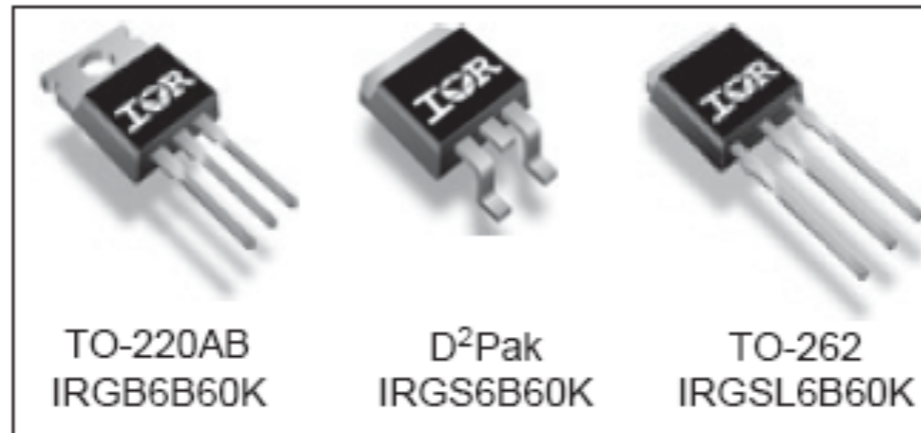
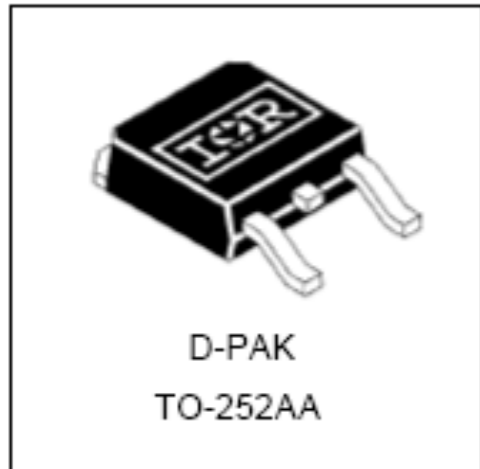

www.irf.com



BJT x MOSFET x IGBT

	MOSFET	IGBT	BJT
Tipo de comando	Tensão	Tensão	Corrente
Potência do comando	Mínima	Mínima	Grande
Complexidade do comando	Simples	Simples	Média
Densidade de corrente	Elevada em baixas tensões e Baixa em altas tensões	Muito elevada	Média
Perdas de comutação	Muito baixa	Baixa para Média	Média para Alta

Componentes Semicondutores:

- Dimensionamento e especificação de semicondutores.

