

Instituto Federal de Educação, Ciência e Tecnologia de Santa Catarina

Departamento Acadêmico de Eletrônica

Projeto de Fontes Chaveadas

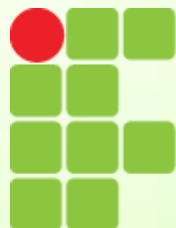

**INSTITUTO FEDERAL
SANTA CATARINA**

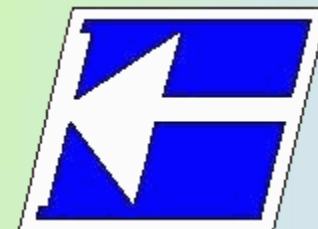

Parte 1 – Fontes Lineares

Semicondutores e Componentes

Retificadores e Filtros Capacitivos

Reguladores Lineares

Partida e Inrush

Prof. Clóvis Antônio Petry.

Florianópolis, fevereiro de 2009.

Bibliografia para esta aula



Disciplina de Conversores Estáticos

The screenshot shows a web browser displaying the homepage for the course 'Conversores Estáticos'. The page has a blue header with navigation links: 'Principal', 'Eventos', 'Links', 'Autor', and 'Contato'. A search bar is present with the text 'Procure documentos nesta página'. Below the header, there are several content boxes: 'Plano de Ensino (2008/1)' with a download icon, 'Datas das Avaliações' listing three evaluation dates, 'Notas da Disciplina' with a calculator icon and contact information, and 'Projeto do Curso' with a download icon. A 'Notas de Aula' table is partially visible at the bottom.

www.cefetsc.edu.br/~petry

Nesta aula

Parte 1 – Fontes lineares:

1. Semicondutores e componentes;
2. Retificadores e filtros capacitivos;
3. Reguladores lineares;
4. Partida e inrush.

Nesta aula

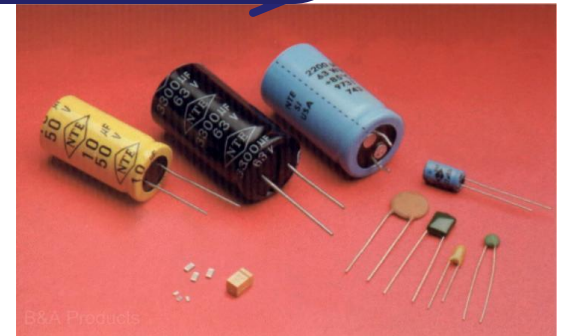
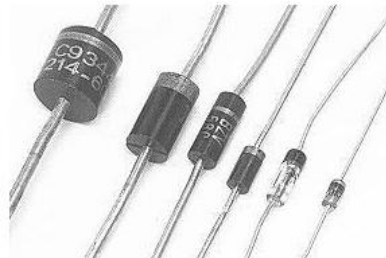
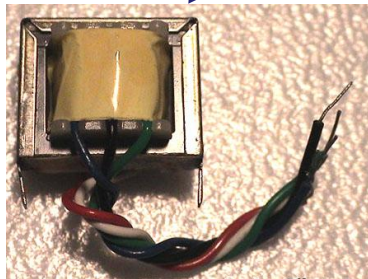
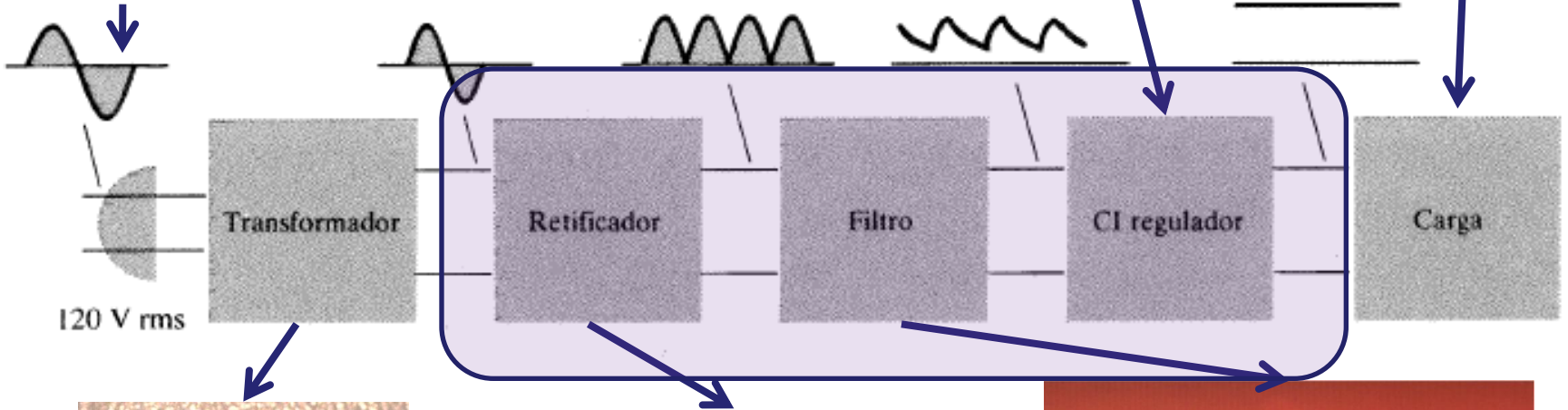
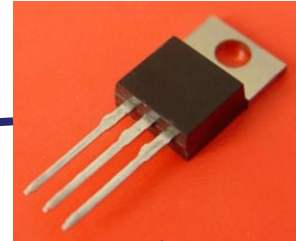
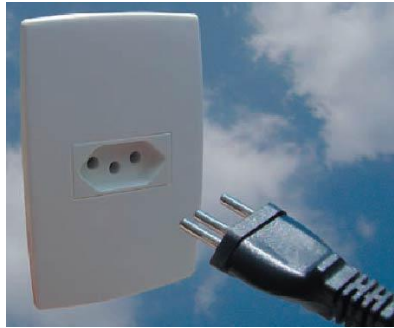

Semicondutores para eletrônica de potência

Semicondutores utilizados em eletrônica de potência:

- Gate turn-off thyristor (GTO)
- Bipolar junction transistor (BJT or BPT)
- Power MOSFET
- Static induction transistor (SIT)
- Insulated gate bipolar transistor (IGBT)
- MOS-controlled thyristor (MCT)
- Integrated gate-commutated thyristor (IGCT)

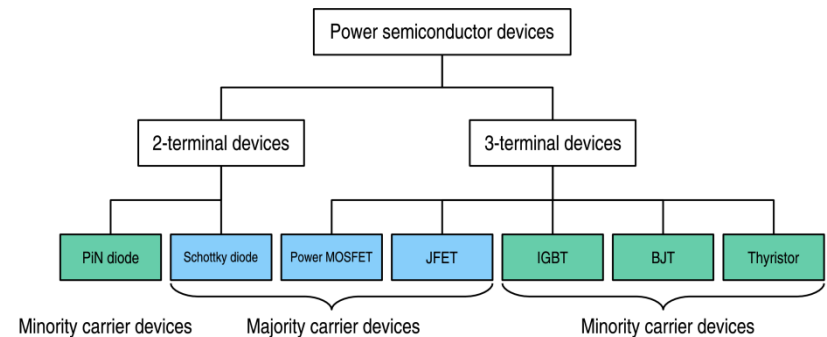

Semicondutores para eletrônica de potência

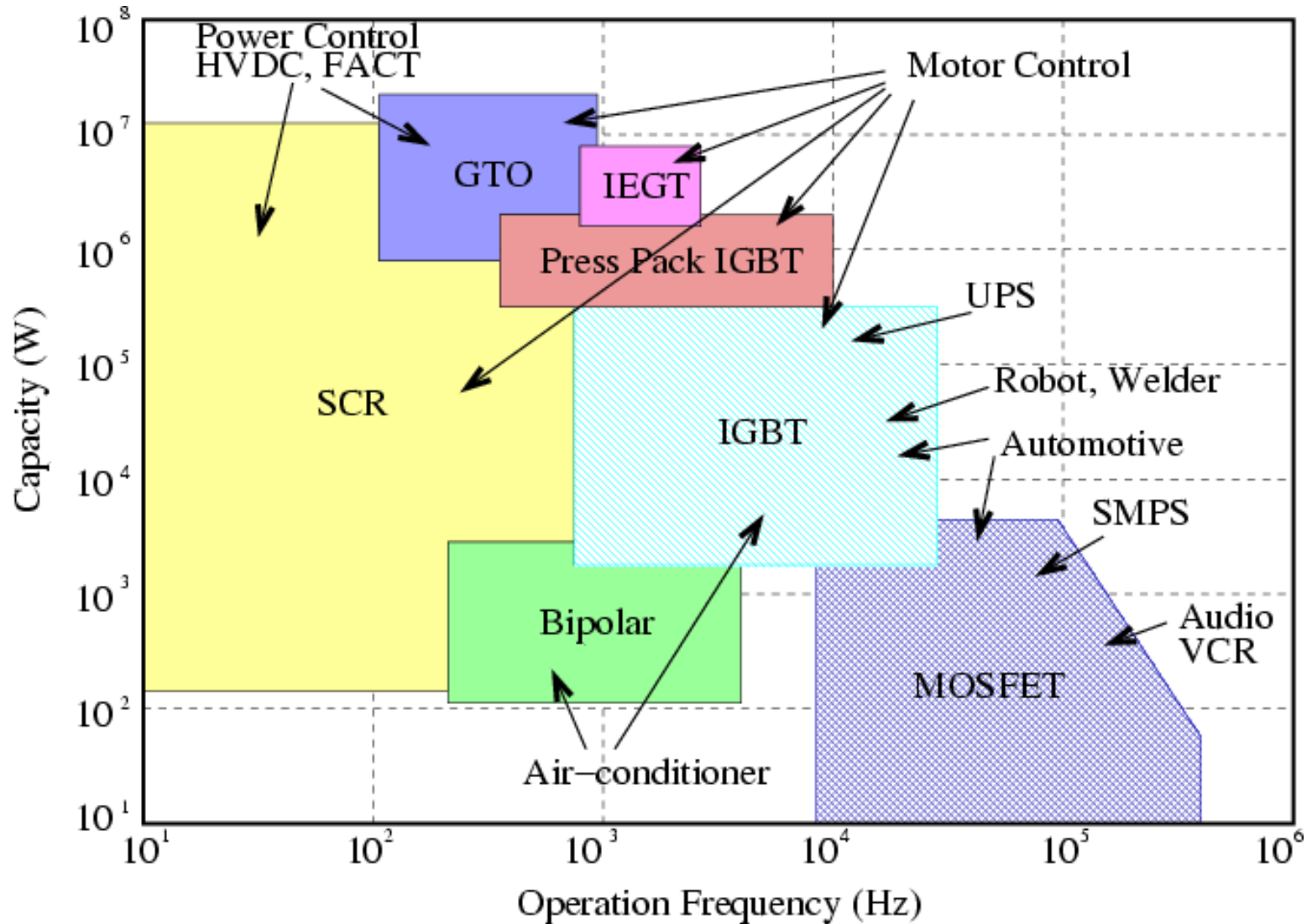

Diodos semicondutores

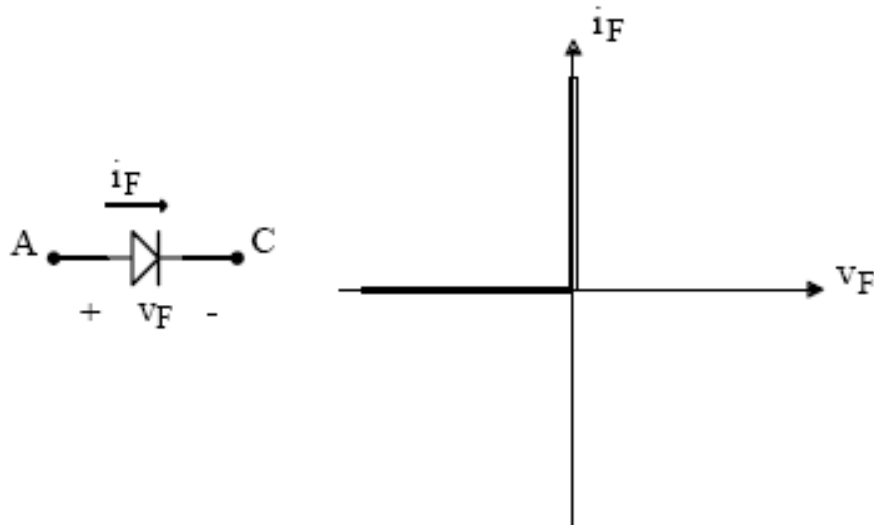

Exemplo: Diodo SKN20/08

- $V_{RRM} = 800 \text{ V}$;
- $V_{(TO)} = 0,85 \text{ V}$;
- $r_T = 11 \text{ m}\Omega$;
- $I_{Dmed} = 20 \text{ A}$;
- $I_R = 0,15 \text{ mA}$.

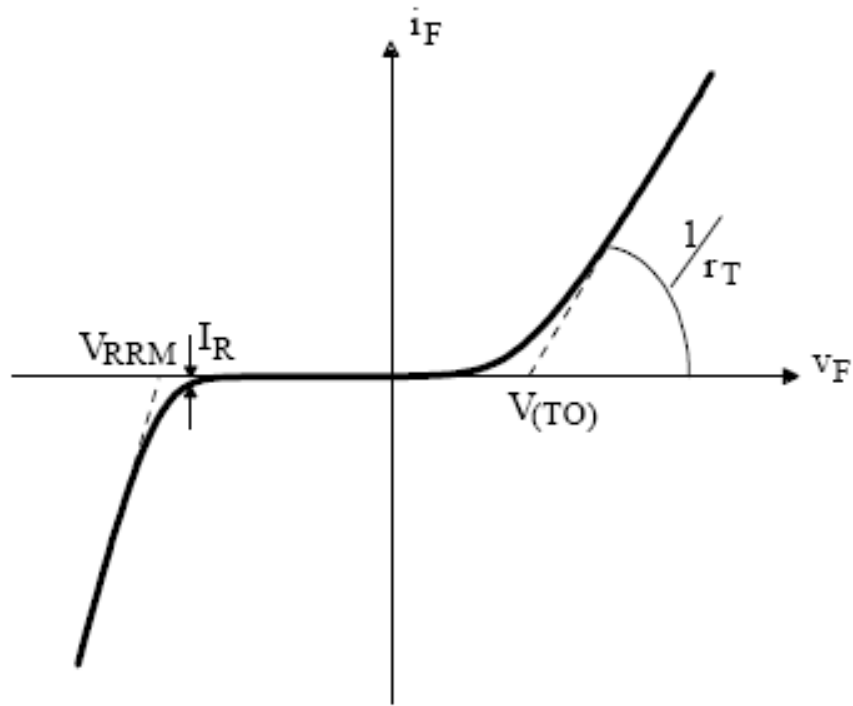
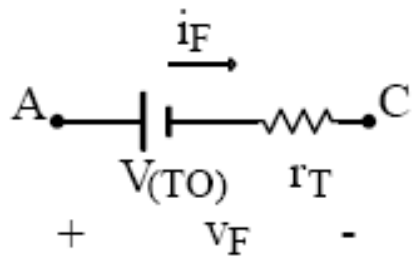

Característica estática

Diodos semicondutores

Bloqueio

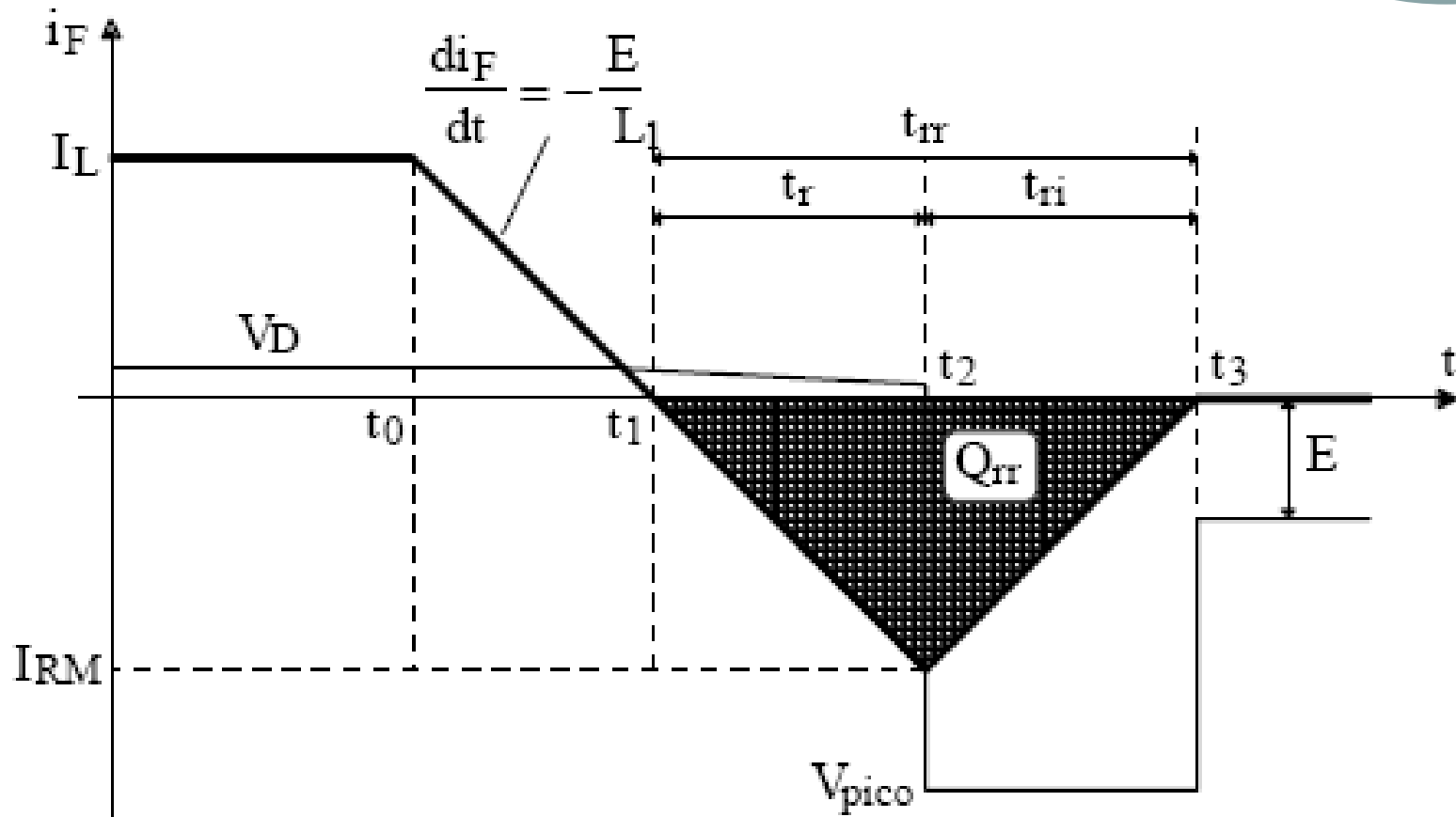

Diodos semicondutores

Diodos de carbeto de s il cio (silicon carbide):

Diminuem acentuadamente o fen meno da recupera o reversa.

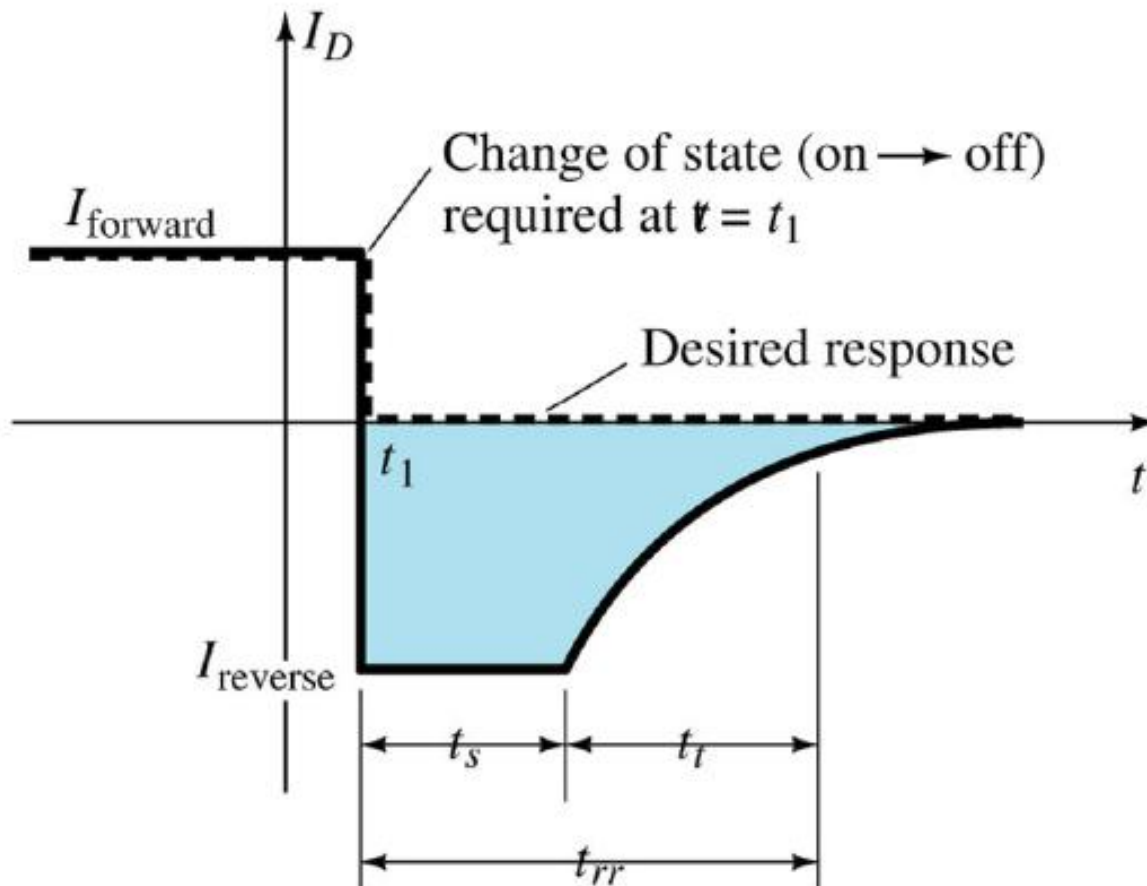

<http://www.infineon.com>

Diodos semicondutores

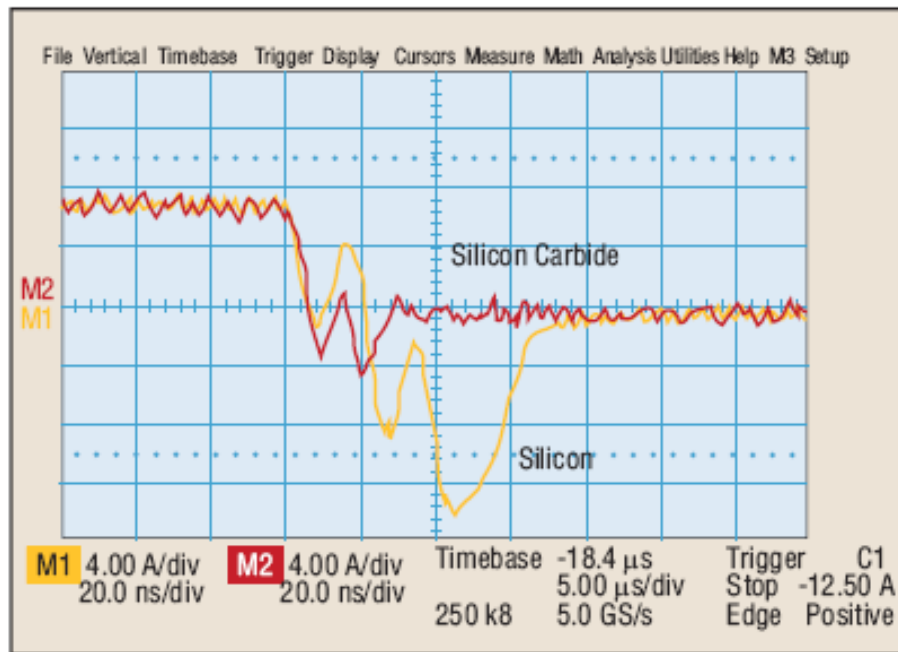

Fig. 4. Low-line diode recovery currents in PFC front-end converter.

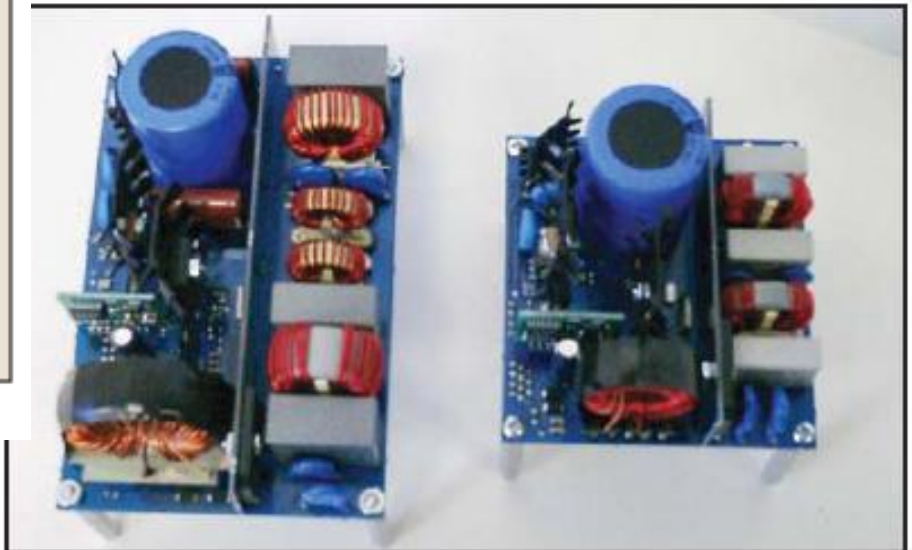

Fig. 8. A size comparison of an 80-kHz PFC front-end built with Si rectifiers (left) and a 200-kHz PFC front-end with SiC rectifiers.

Perdas nos diodos

Classificação das perdas:

1. Condução;

$$P = V_{(TO)} \cdot I_{Dmed} + r_T \cdot I_{Def}^2$$

2. Comutação:

- Entrada em condução;

$$P_1 = 0,5(V_{FP} - V_F) I_o \cdot t_{rf} \cdot f$$

- Bloqueio.

$$P_2 = Q_{rr} \cdot E \cdot f$$

Características importantes dos diodos

Principais características:

1. Tensão de pico reversa;
2. Queda de tensão direta;
3. Corrente de pico;
4. Corrente média;
5. Corrente eficaz;
6. Tempo de recuperação reversa.

MURD320

MAXIMUM RATINGS

Rating	Symbol	Value	Unit
Peak Repetitive Reverse Voltage Working Peak Reverse Voltage DC Blocking Voltage	V_{RRM} V_{RWM} V_R	200	V
Average Rectified Forward Current (Rated V_R , $T_C = 158^\circ\text{C}$)	$I_{F(AV)}$	3.0	A
Peak Repetitive Forward Current (Rated V_R , Square Wave, 20 kHz, $T_C = 158^\circ\text{C}$)	I_{FRM}	6.0	A
Non-Repetitive Peak Surge Current (Surge Applied at Rated Load Conditions Halfwave, 60 Hz)	I_{FSM}	75	A
Operating Junction and Storage Temperature Range	T_J, T_{stg}	-65 to +175	$^\circ\text{C}$

THERMAL CHARACTERISTICS

Rating	Symbol	Value	Unit
Thermal Resistance – Junction-to-Case	$R_{\theta JC}$	6	$^\circ\text{C/W}$
Thermal Resistance – Junction-to-Ambient (Note 1)	$R_{\theta JA}$	80	$^\circ\text{C/W}$

ELECTRICAL CHARACTERISTICS

Maximum Instantaneous Forward Voltage Drop (Note 2) ($I_F = 3$ Amps, $T_J = 25^\circ\text{C}$) ($I_F = 3$ Amps, $T_J = 125^\circ\text{C}$)	V_F	0.95 0.75	Volts
Maximum Instantaneous Reverse Current (Note 2) ($T_J = 25^\circ\text{C}$, Rated dc Voltage) ($T_J = 125^\circ\text{C}$, Rated dc Voltage)	i_R	5 500	μA
Maximum Reverse Recovery Time ($I_F = 1$ Amp, $di/dt = 50$ Amps/ μs , $V_R = 30$ V, $T_J = 25^\circ\text{C}$) ($I_F = 0.5$ Amp, $i_R = 1$ Amp, $I_{REC} = 0.25$ A, $V_R = 30$ V, $T_J = 25^\circ\text{C}$)	t_{rr}	35 25	ns

Características de diodos comerciais

Tipos de diodos de potência:

1. Standard and fast recovery;
2. Ultrafast rectifiers;
3. Ultrasoft rectifiers;
4. Silicon carbide (zero recovery).

Rectifiers (227)

- Standard and Fast Recovery Rectifiers (55)
- UltraFast Rectifiers (165)
- UltraSoft Rectifiers (7)

ON Semiconductor® Selection. Service. Support. Power Solutions from ON Semiconductor

HOME PRODUCTS DESIGN SUPPORT APPLICATIONS QUALITY My ON: Sign In or Register

Browse Semiconductor Equipment & Parts

Power Management (2860)
Off-Line Controllers (232)
Off-Line Regulators (108)
Power Factor Correction (33)
Battery Management (34)
DC-DC Switching (370)
Hot Swap Controllers (2)
Linear Voltage Regulators (1627)
Voltage References (119)
Voltage Supervisors (335)

Bipolar Transistors (1555)
Audio Transistors (121)
Bias Resistor Transistors (BRTs) (210)
Darlington Transistors (221)
General Purpose Transistors (910)
Insulated Gate Bipolar Transistors (IGBTs) (19)
Low V_{CE(sat)} Transistors (58)
RF Transistors (up to 2 GHz) (16)

EMI / RFI Filters (44)
Audio Filters (5)
Data Filters (39)

Diodes (2158)
ESD Protection Diodes (100)
Schottky Diodes & Rectifiers (355)
Small Signal Switching Diodes (184)
Transient Voltage Suppressors (TVS) (642)
Tuning Diodes (14)
Zener Diodes (863)

Clock Managers (492)
Clock Distributors (261)
Clock Modules (5)
Clock Synthesizers (65)
EMI Suppression Clocks (24)
Phase / Frequency Detectors (PLL) (20)
Skew Managers (38)
VCO (PLL) (29)
Zero Delay Buffers (50)

FETs (646)
JFETs (31)
MOSFETs (598)
Protected MOSFETs (17)

Analog Switches (245)
Audio Switches (26)
Data Switches (9)
General Purpose Switches (206)
Video Switches (4)

Thyristors (459)
Programmable Unijunction Transistors (PUTs) (13)
SIDACs (10)
Silicon Controlled Rectifiers

Rectifiers (227)
Standard and Fast Recovery Rectifiers (55)
UltraFast Rectifiers (165)
UltraSoft Rectifiers (7)

Amplifiers & Drivers (182)
Display / LED Drivers (32)
Load / Relay Drivers (40)
MOSFET / IGBT Drivers (71)
Motor Drivers (39)

Applications
Automotive
Circuit Protection
Computing and Peripherals
Consumer and Portable
Industrial and Medical
Networking and Telecommunications
LED Lighting
Power Supply

Design Support
Technical Documentation
Design Resources
Technical Support
Sales Support

Environmental Programs
Pb-free Program
China RoHS
Halogen Free Mold Compounds
Green Partner Certificates

Product Services
Check Availability

Características de diodos comerciais

1N5400 thru 1N5408

1N5404 and 1N5406 are Preferred Devices

Axial-Lead Standard Recovery Rectifiers

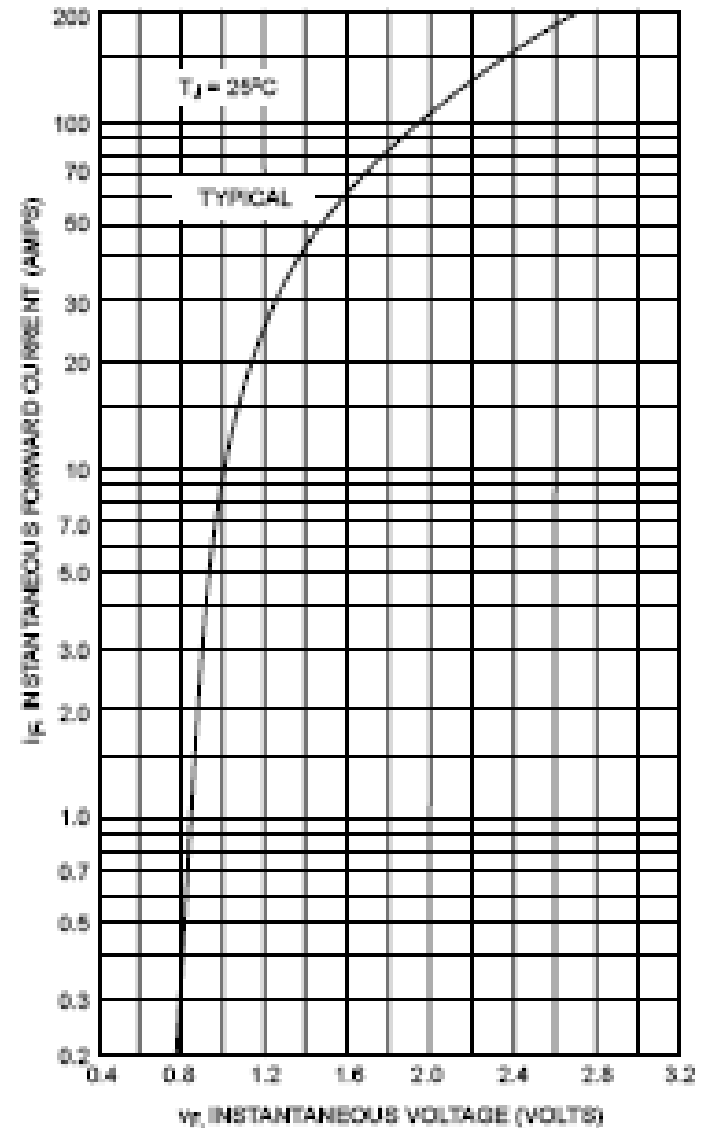
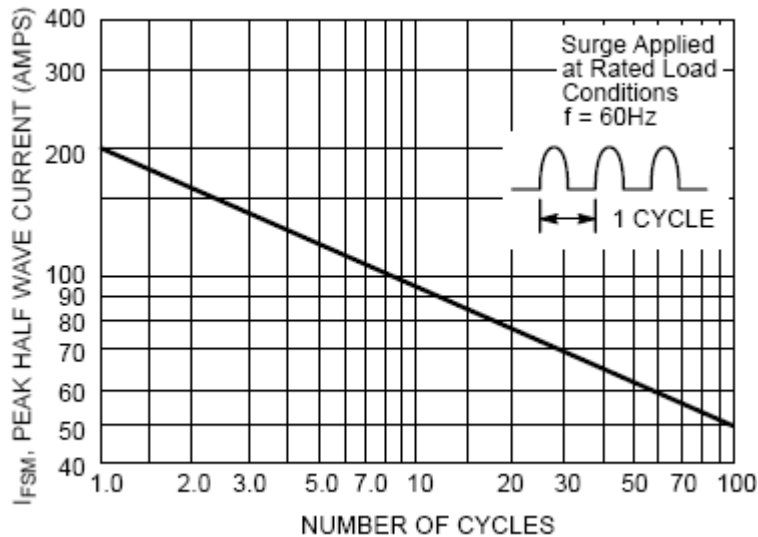

Capacitores

Capacitância depende de:

- Dielétrico (permissividade);
- Área das placas;
- Distância entre as placas.

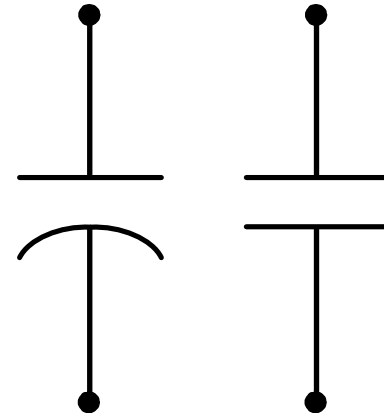
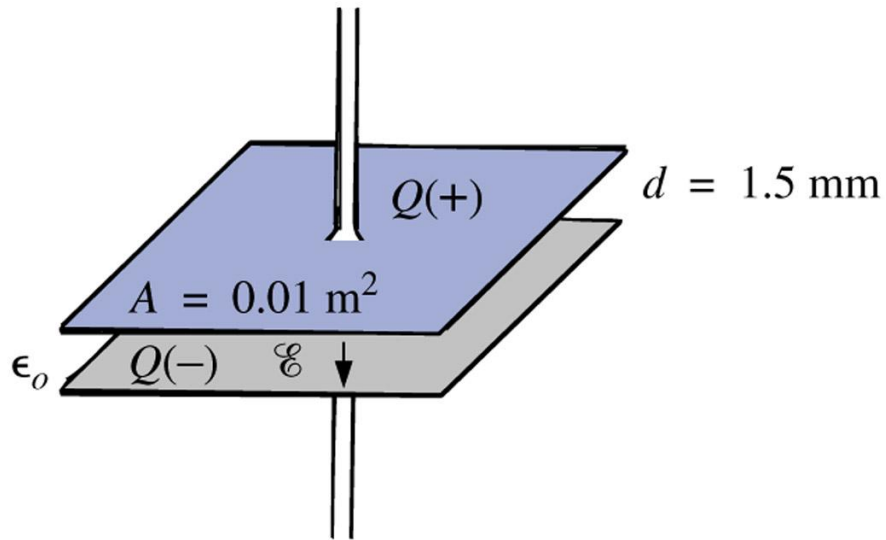

Capacitores



Modelo equivalente do capacitor

Onde:

- C = Capacitância;
- RSE = Resistência série equivalente;
- LSE = Indutância série equivalente.

Perdas devido à RSE:

$$P = RSE \cdot I_{ef}^2$$

Capacitores



Ondulação da tensão:

$$\Delta V = RSE \cdot \Delta I$$

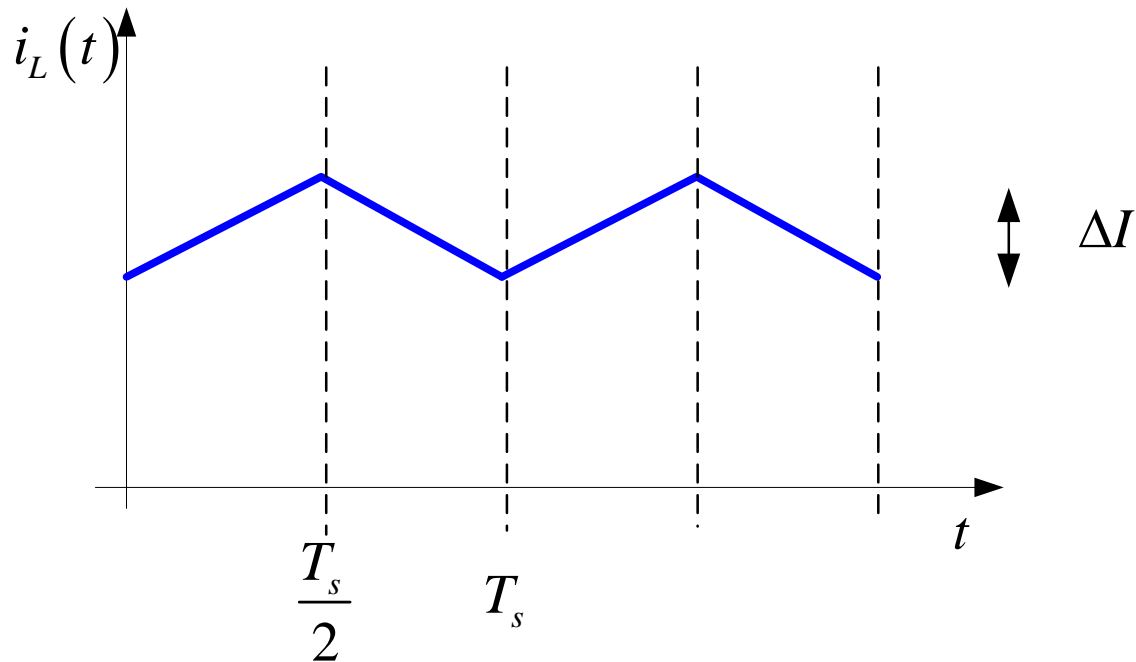

Capacitores

Tecnologias de capacitores:

- Filtro do retificador de entrada – São empregados capacitores eletrolíticos de alta tensão e grandes capacitâncias;
- Filtro de saída dos conversores – Empregam-se capacitores eletrolíticos alumínio com baixa RSE;
- Circuitos de grampeamento (snubber) – São utilizados capacitores com dielétricos de polipropileno para regime intermitente de funcionamento.

Capacitores

Tipos de capacitores:



Capacitores de disco de cerâmica.

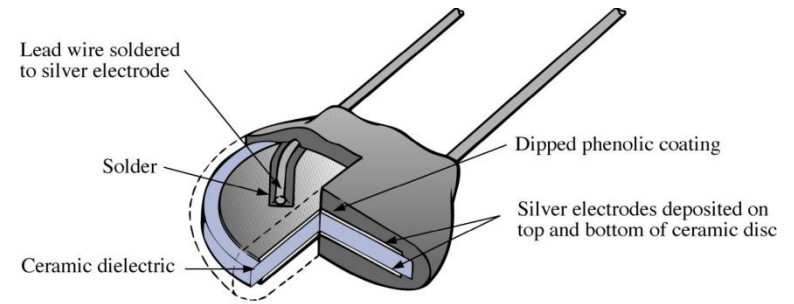

(b)

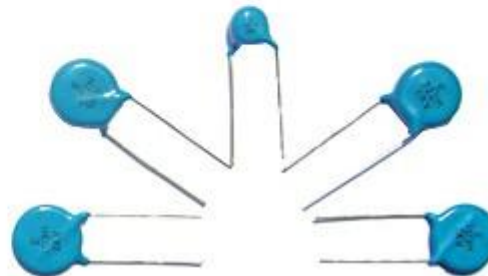
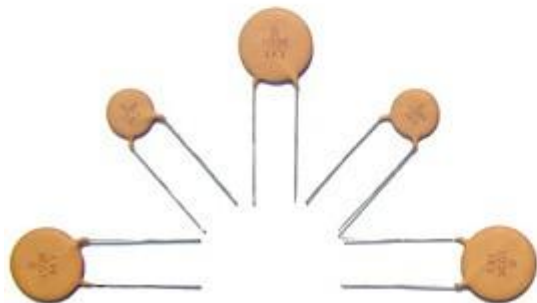

Capacitores

Tipos de capacitores:

Capacitores eletrolíticos.

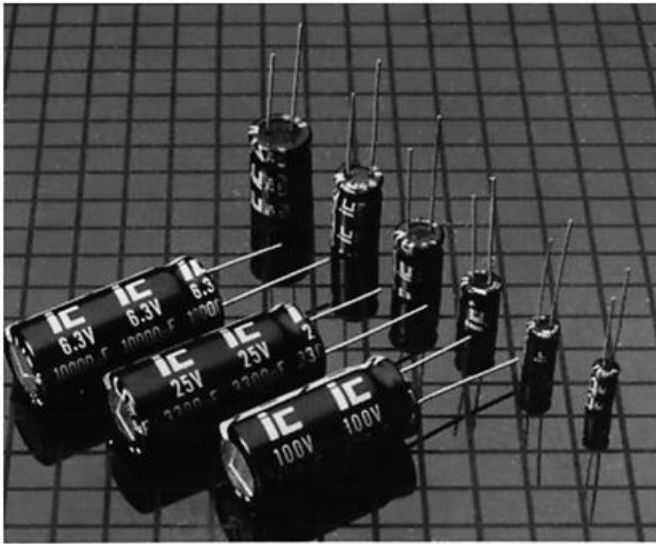

(a)

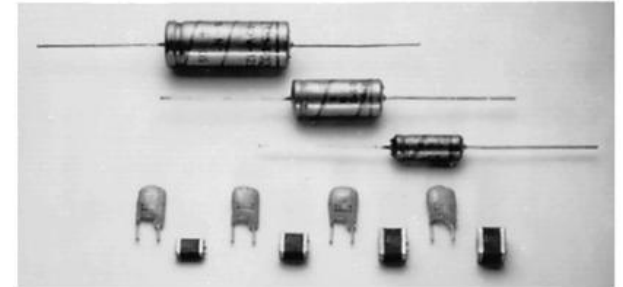

(b)



Capacitores

Tipos de capacitores:

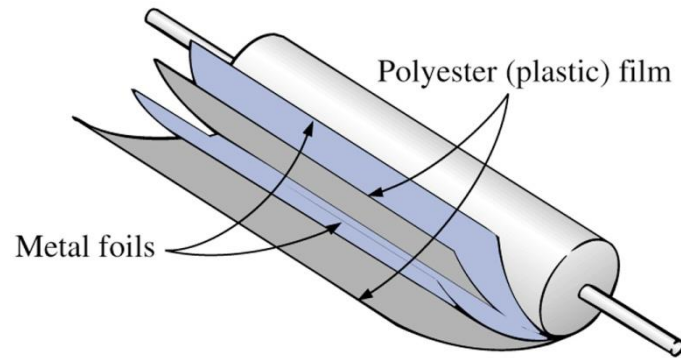

Capacitores de filme de poliéster.

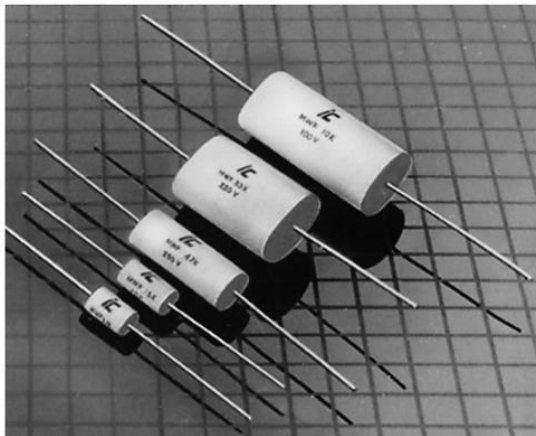

(a)

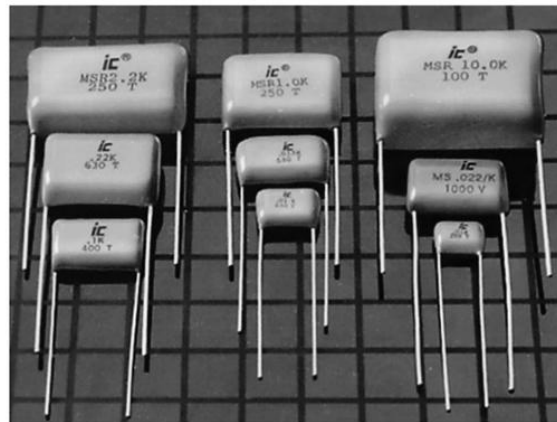

(b)

Capacitores

Tipos de capacitores:

Super capacitores



Small capacitance	3F, 2.3V – 300F, 2.3V	back-up power, on-board UPS, etc.
Medium capacitance	300F, 2.3V – 5000F, 2.7V	peak power, UPS, etc.
Large capacitance	5000F, 2.7V – 80.000F, 1.8 V	peak power, low maintenance energy storage, etc.
Supercapacitor modules	5V- 700V, capacitance on request.	Higher voltage applications



Capacitores

Exemplo: capacitores para UPS

Capacitor overview

<p>Power capacitors MKP series E3236*</p> 		<p>Film capacitors MKP series E3266* E3267* E3277*</p> 
<p>Preferably 3-phase AC power capacitors PhaseCap MKK series E25667 E25668</p> 		<p>Film capacitors Snubber series E3263* E3266S* E3268*</p> 
<p>Aluminum electrolytic capacitors Screw, snap-in, 4-pin snap-in, solder-pin terminals E433*, E434*, E435* E436*, E437*</p> 		<p>EMI capacitors X and Y series E3202* E3202*</p> 

<http://www.epcos.com> >> Publications

Fusíveis

Fusíveis de ação lenta:

- Vidro;
- Areia;
- Cerâmica.

Fusíveis de ação rápida:

- Vidro;
- Areia;
- Cerâmica.

Resistores fusíveis.

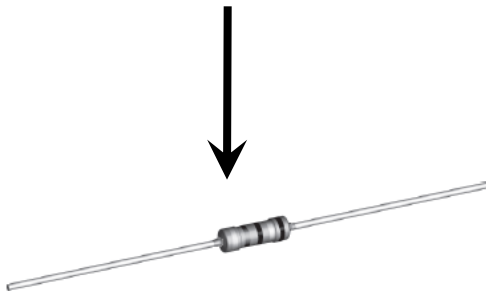

Fusíveis

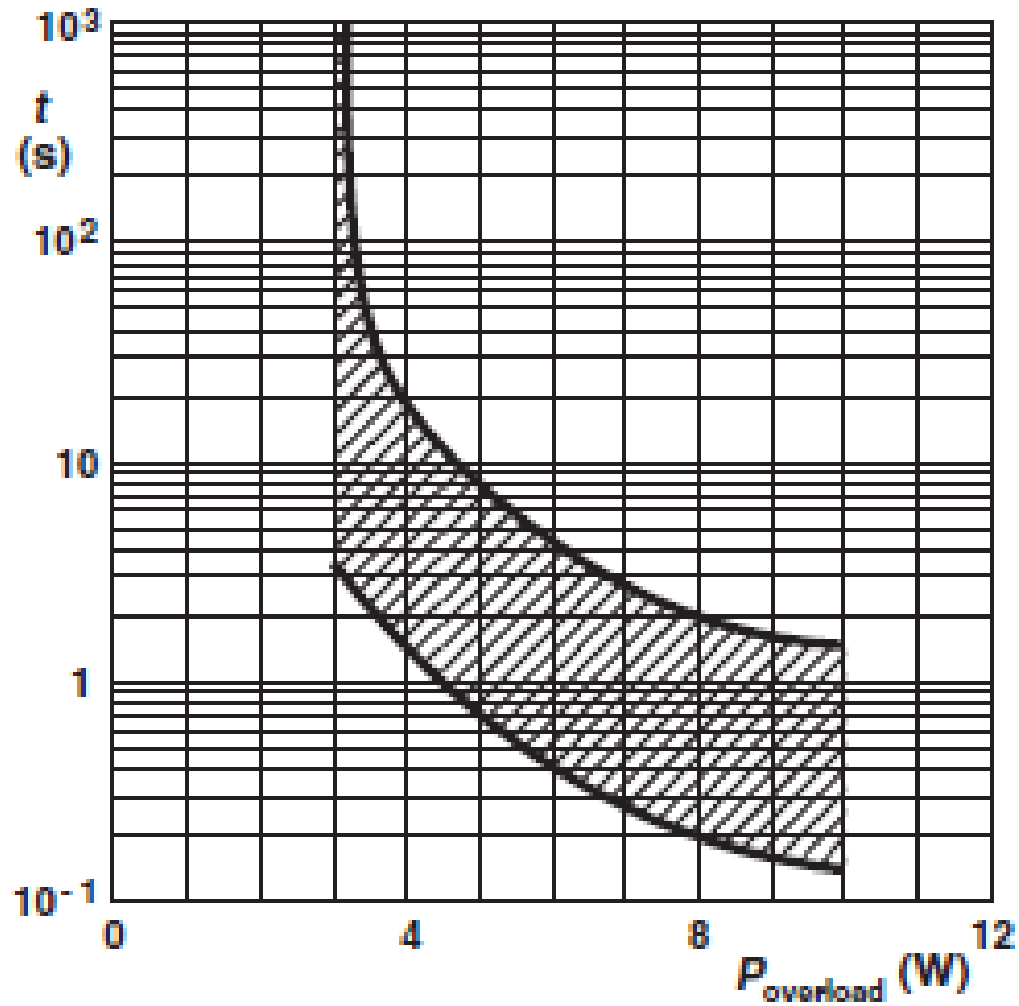

NR25 – $1 \Omega < R < 15 \Omega$

Termistores

Termistor:

- Resistor cuja resistência é sensível à variação da temperatura.

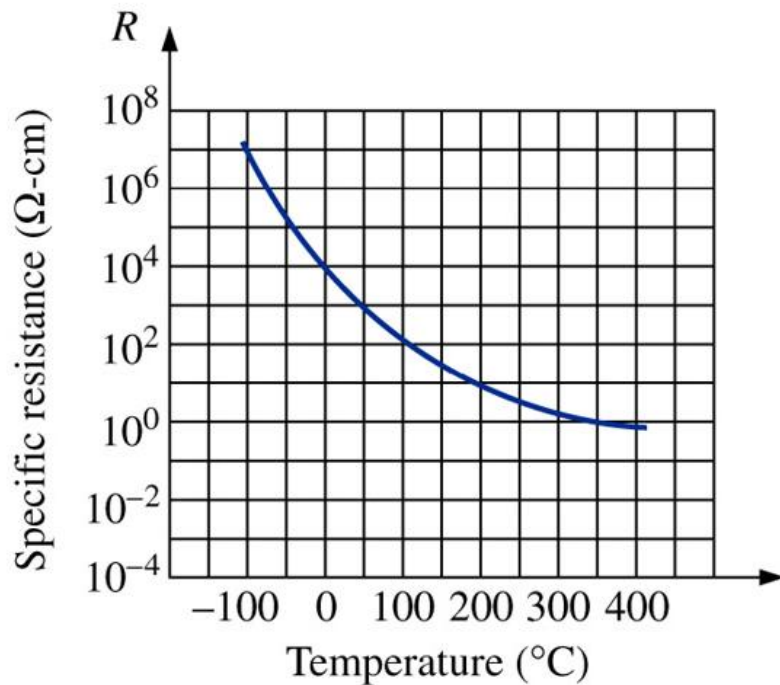

(a)



(b)

Termistores

Termistor NTC:

- Coeficiente negativo de temperatura;
- Resistência diminui com o aumento da temperatura.

Termistor PTC:

- Coeficiente positivo de temperatura;
- Resistência aumenta com o aumento da temperatura.

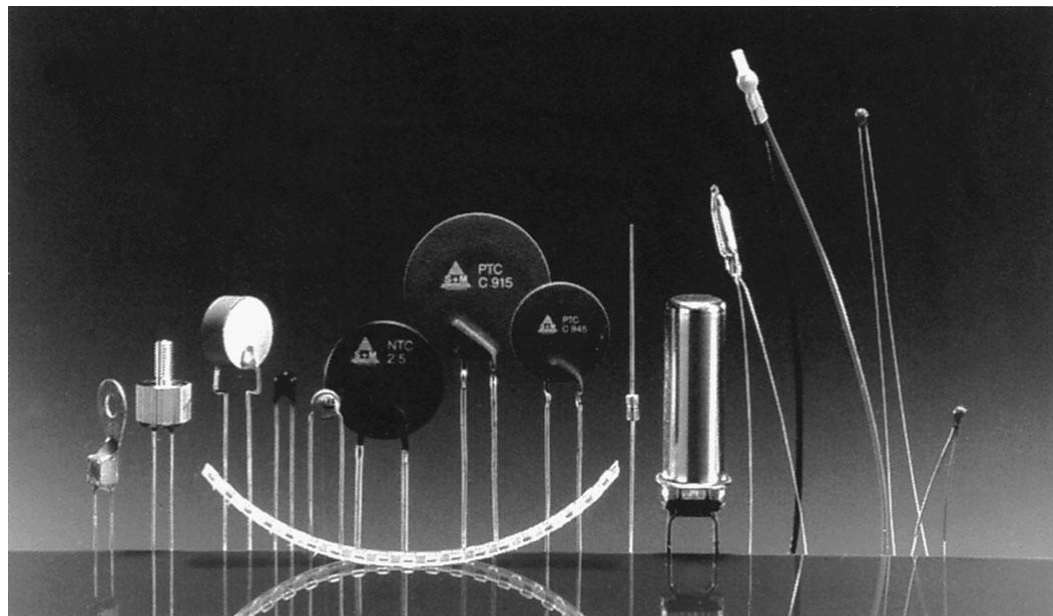

Retificadores e filtros capacitivos

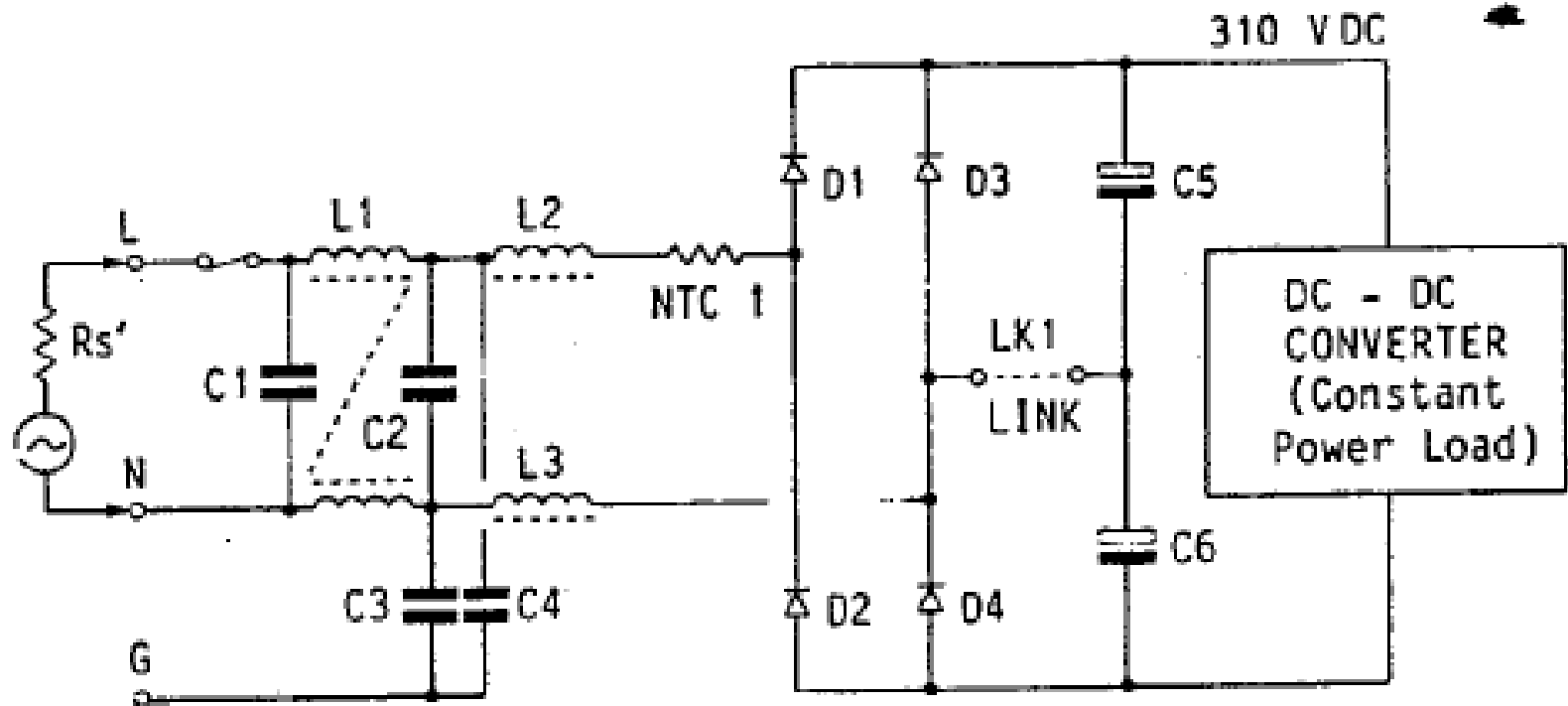

Estágio de entrada de uma fonte chaveada

Retificadores e filtros capacitivos

Carga resistiva:

Circuito do retificador

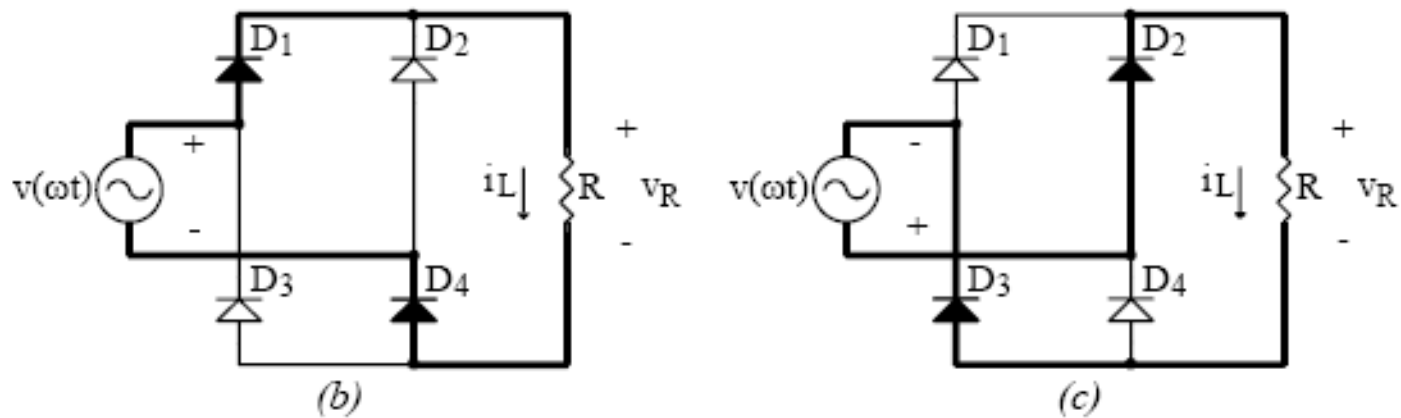
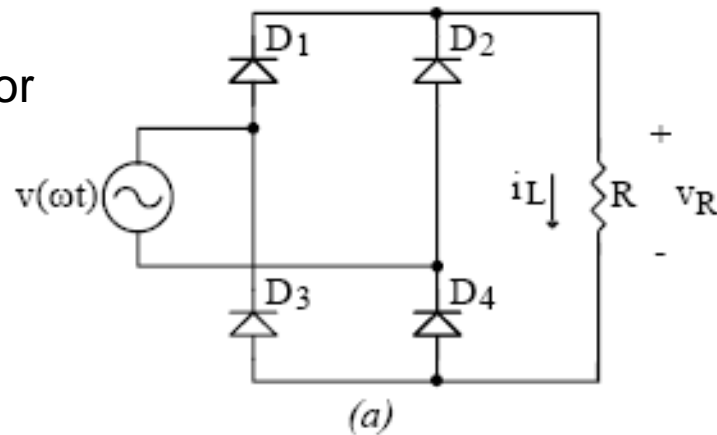

Etapas de operação

Retificadores e filtros capacitivos

Carga resistiva:

Tensão e corrente média na carga:

$$V_{Lmed} = \frac{2\sqrt{2} \cdot V_2}{\pi} \cong 0,9 \cdot V_2$$

$$I_{Lmed} = \frac{2\sqrt{2} \cdot V_o}{\pi R} \cong \frac{0,9 \cdot V_o}{R}$$

Retificadores e filtros capacitivos

Análise simplificada:

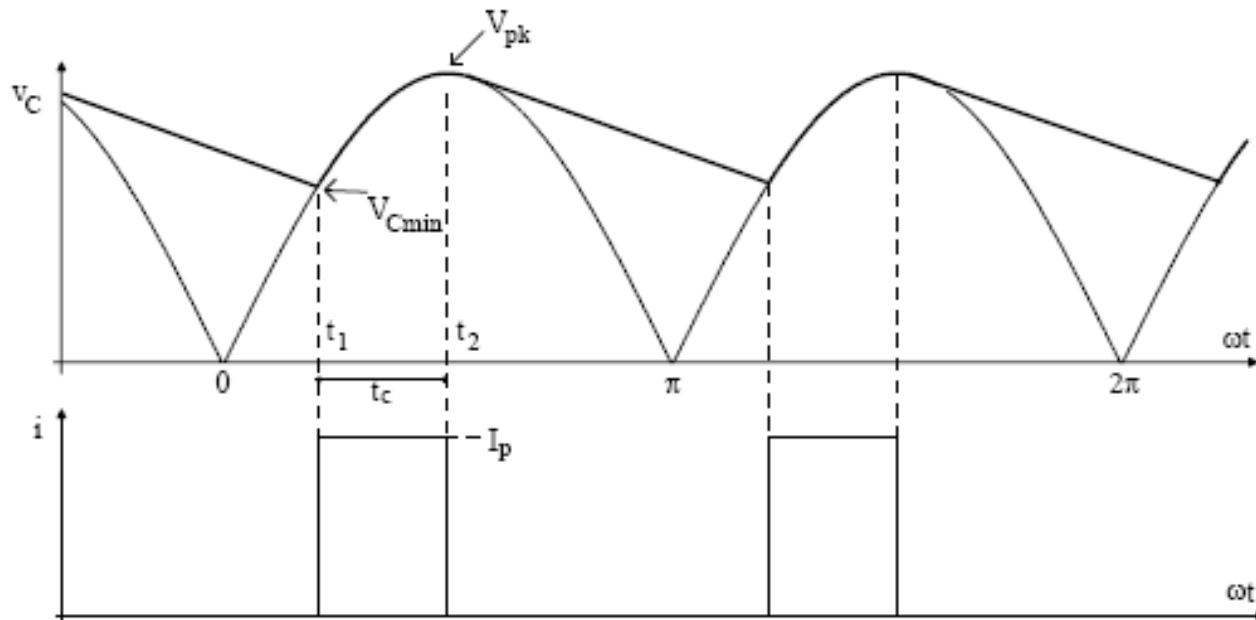
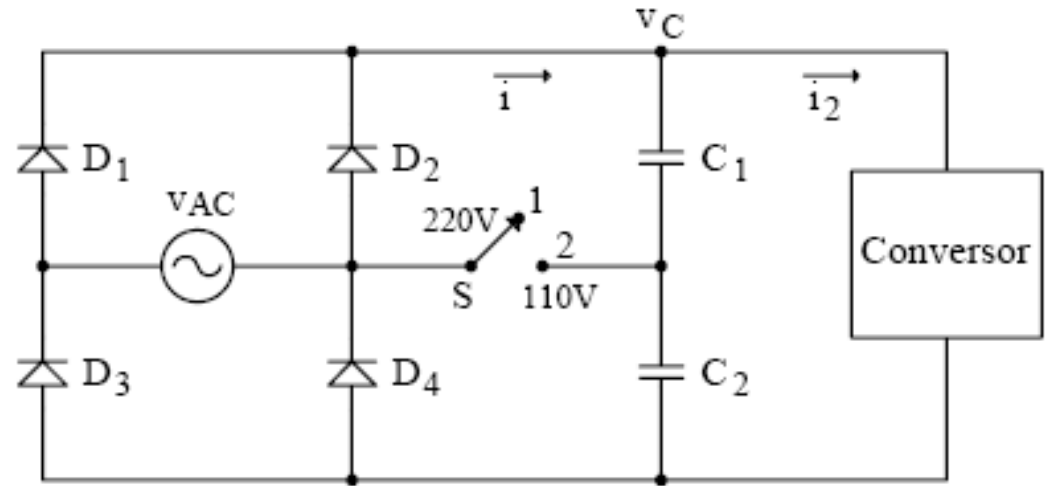

Retificadores e filtros capacitivos

Análise simplificada:

$$C = C_1 // C_2 = \frac{C_1 \cdot C_2}{C_1 + C_2}$$

$$\frac{W_{in}}{2} = \frac{1}{2} \cdot C \cdot (V_{pk}^2 - V_{Cmin}^2)$$

$$W_{in} = \frac{P_{in}}{f}$$

$$V_{Cmin} = V_{pk} \cdot \cos(2\pi \cdot f \cdot t_c)$$

$$t_c = \frac{\cos^{-1}\left(\frac{V_{Cmin}}{V_{pk}}\right)}{2\pi \cdot f}$$

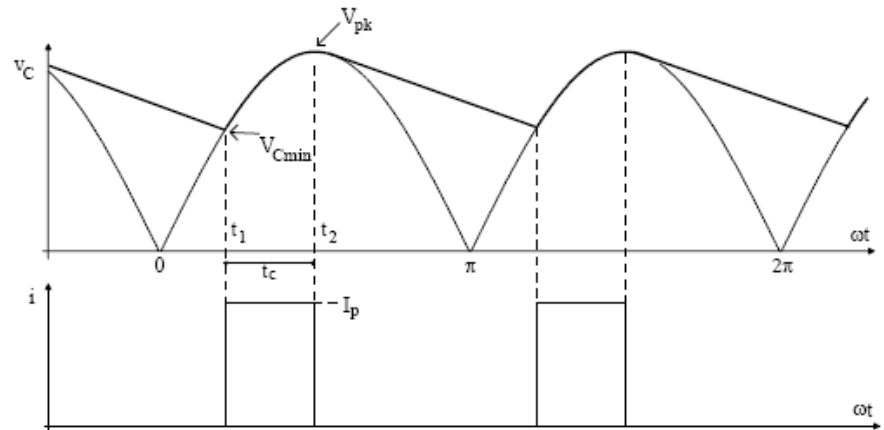

$$\Delta Q = I_p \cdot t_c = C \cdot \Delta V$$

$$I_p = \frac{C \cdot \Delta V}{t_c} = \frac{C \cdot (V_{pk}^2 - V_{Cmin}^2)}{t_c}$$

$$C \cdot (V_{pk}^2 - V_{Cmin}^2) = \frac{P_{in}}{f}$$

$$C = \frac{P_{in}}{f \cdot (V_{pk}^2 - V_{Cmin}^2)}$$

Retificadores e filtros capacitivos

Análise simplificada:

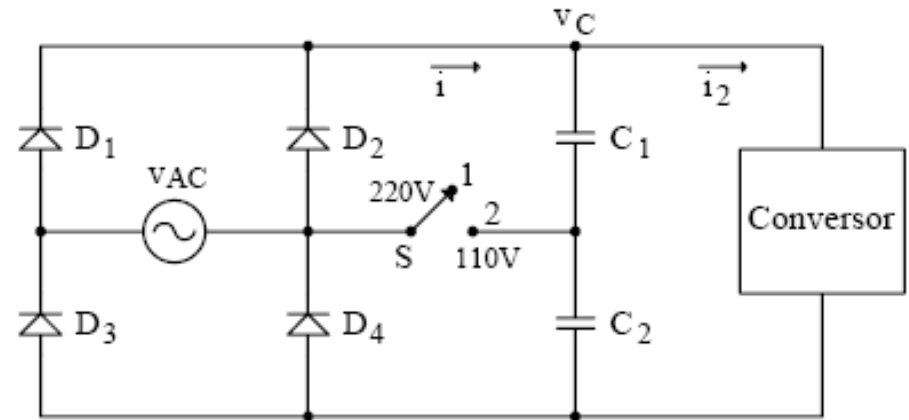

I_{ef} = valor eficaz da componente alternada de i ;

I_{med} = valor médio de i ;

I_{C1ef} = valor eficaz de i .

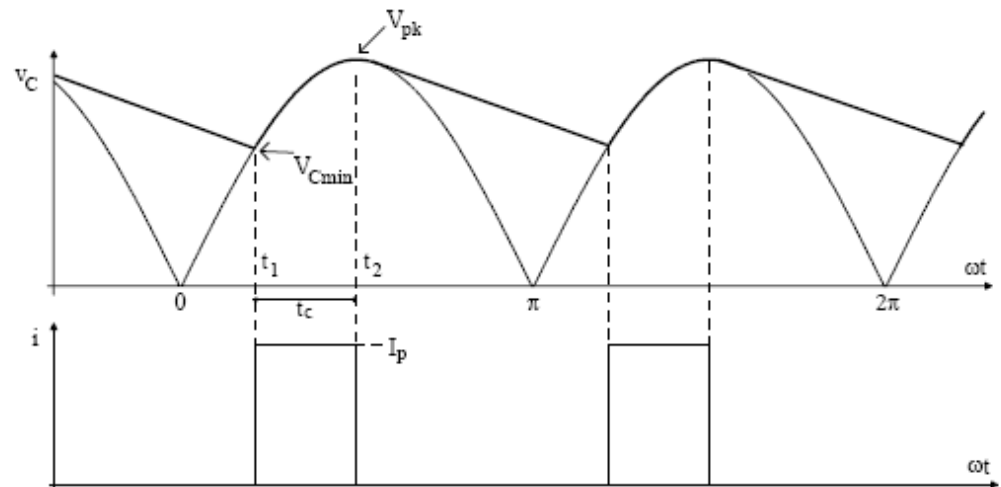

Retificadores e filtros capacitivos

Análise simplificada:

$$I_{C1ef}^2 = I_{med}^2 + I_{ef}^2$$

$$I_{ef} = \sqrt{I_{C1ef}^2 - I_{med}^2}$$

$$I_{med} = I_p \cdot \frac{2 \cdot t_c}{T}$$

$$I_{C1ef} = I_p \sqrt{\frac{2 \cdot t_c}{T}}$$

$$I_{ef} = I_p \sqrt{2 \cdot t_c \cdot f - (2 \cdot t_c \cdot f)^2}$$

$$P_{in} = I_{pk} \cdot V_{Cmin} \cdot D$$

$$D = \frac{T_{on}}{T}$$

$$I_{pk} = \frac{P_{in}}{V_{Cmin} \cdot D}$$

$$P_{in} = \frac{P_{out}}{\eta}$$

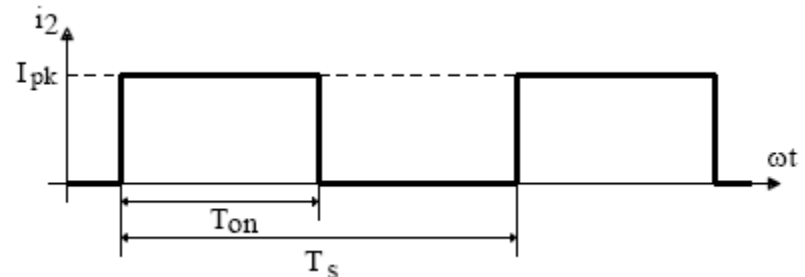

Retificadores e filtros capacitivos

Análise simplificada:

$$I_{Cef} = \sqrt{I_{2ef}^2 + I_{ef}^2}$$

$$I_{Dmed} = \frac{P_{in}}{2 \cdot V_{Cmin}}$$

$$I_{Def} = I_p \sqrt{\frac{t_c}{T}}$$

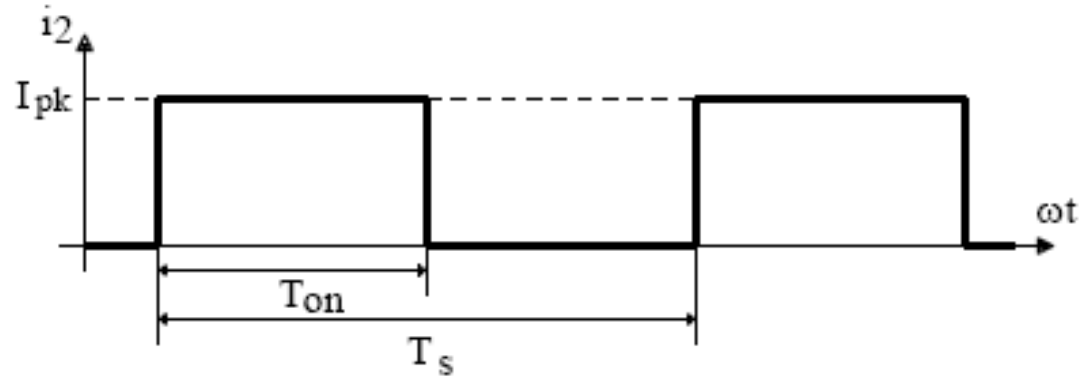

Retificadores e filtros capacitivos

Análise simplificada (exemplo numérico):

Retificador de entrada de uma fonte chaveada:

$$V_{AC} = 117V \quad V_{AC\min} = 99V \quad V_{AC\max} = 135V$$

$$f = 60\text{Hz} \quad V_{C\min} = 100V \quad \eta = 0,7 \quad P_{out} = 70W$$

$$\text{a) } P_{in} = \frac{P_{out}}{\eta} = \frac{70}{0,7} = 100W$$

$$\text{b) } V_{pk} = \sqrt{2} \cdot V_{AC\min} = \sqrt{2} \cdot 99 = 140V \quad C_1 = C_2 = 406\mu F$$

$$\Delta V = V_{pk} - V_{C\min} = 135 - 100 = 35V$$

$$C = \frac{P_{in}}{f \cdot (V_{pk}^2 - V_{C\min}^2)} = \frac{100}{60 \cdot (135^2 - 100^2)} \cong 203\mu F$$

Retificadores e filtros capacitivos

Análise simplificada:

$$\text{c) } t_c = \frac{\cos^{-1}\left(\frac{V_{C\min}}{V_{pk}}\right)}{2\pi \cdot f} = \frac{\cos^{-1}\left(\frac{100}{135}\right)}{2\pi \cdot 60} = 1,954 \text{ ms}$$

$$\text{d) } I_p = \frac{C \cdot \Delta V}{t_c} = \frac{203\mu \cdot 35}{1,954\text{m}} = 3,64 \text{ A}$$

$$\text{e) } 2 \cdot t_c \cdot f = 2 \cdot 1,954\text{m} \cdot 60 = 0,2345$$

$$I_{ef} = I_p \sqrt{2 \cdot t_c \cdot f - (2 \cdot t_c \cdot f)^2} = 3,64 \sqrt{0,2345 - (0,2345)^2} = 1,54 \text{ A}$$

Retificadores e filtros capacitivos

Análise simplificada:

$$\text{f) } I_{2ef} = \frac{P_{in}}{V_{C\min}} = \frac{100}{100} = 1 \text{ A}$$

$$\text{g) } I_{Cef} = \sqrt{I_{2ef}^2 + I_{ef}^2} = \sqrt{1^2 + 1,54^2}$$

$$\text{h) } I_{Def} = I_p \sqrt{\frac{t_c}{T}} = 3,64 \sqrt{\frac{1,954\text{m}}{16,67\text{m}}} = 1,25 \text{ A}$$

$$\text{i) } I_{Dmed} = \frac{P_{in}}{2 \cdot V_{C\min}} = \frac{100}{2 \cdot 100} = 0,5 \text{ A}$$

$$\text{j) } V_{D\max} = V_{pk\max} = \sqrt{2} \cdot V_{AC\max} = \sqrt{2} \cdot 135 = 191 \text{ V}$$

$$\text{k) } I_{Dp} = I_p = 3,64 \text{ A}$$

Retificadores e filtros capacitivos

Análise simplificada:

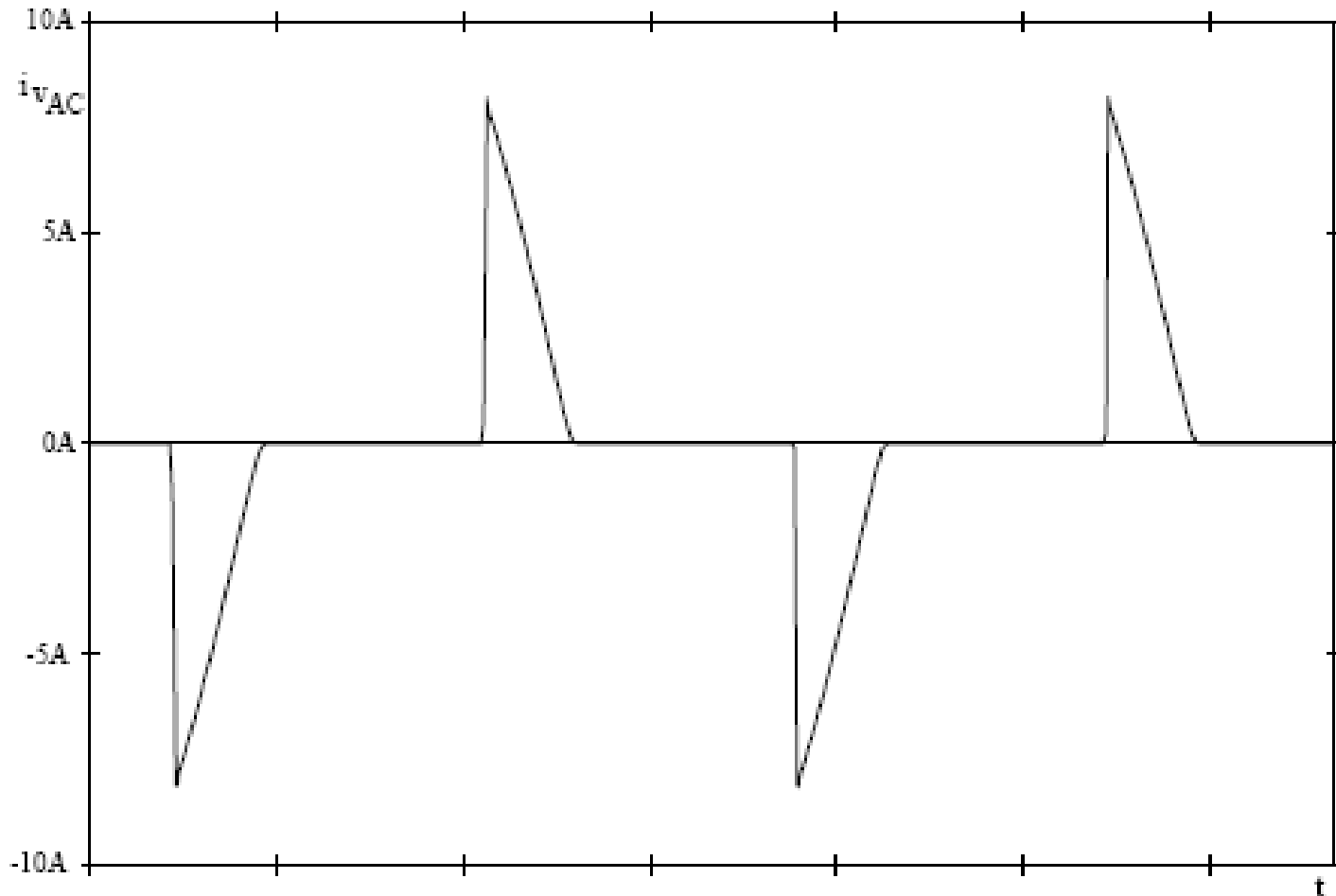

Retificadores e filtros capacitivos

Dobrador de tensão:

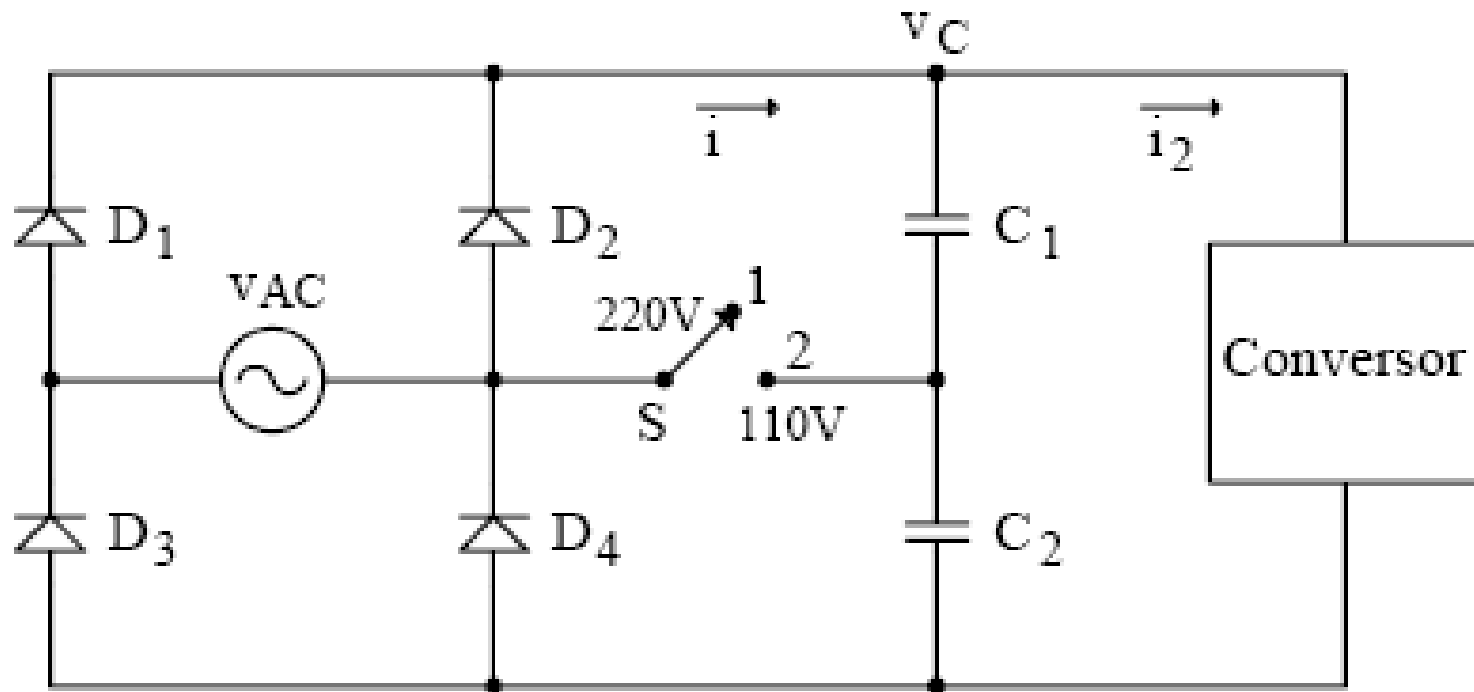

Retificadores e filtros capacitivos

Descrição do funcionamento:

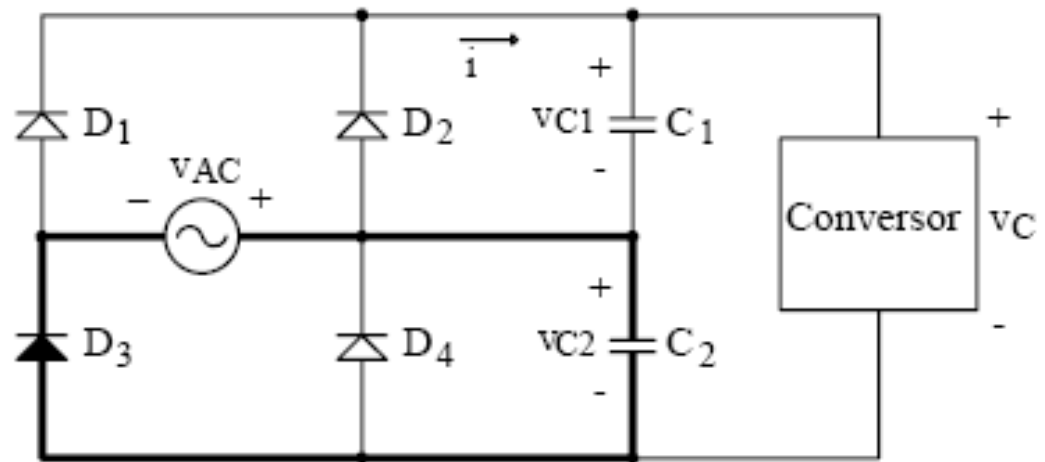
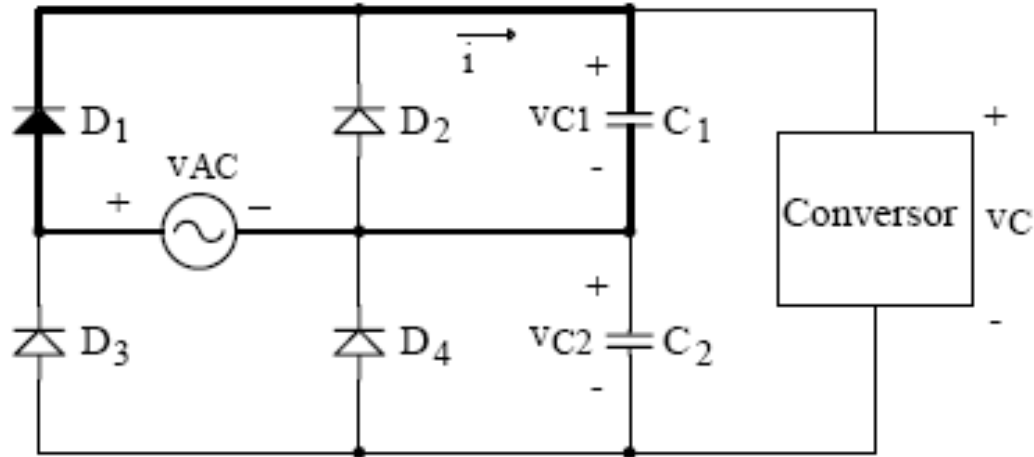

Retificadores e filtros capacitivos

Descrição do funcionamento:

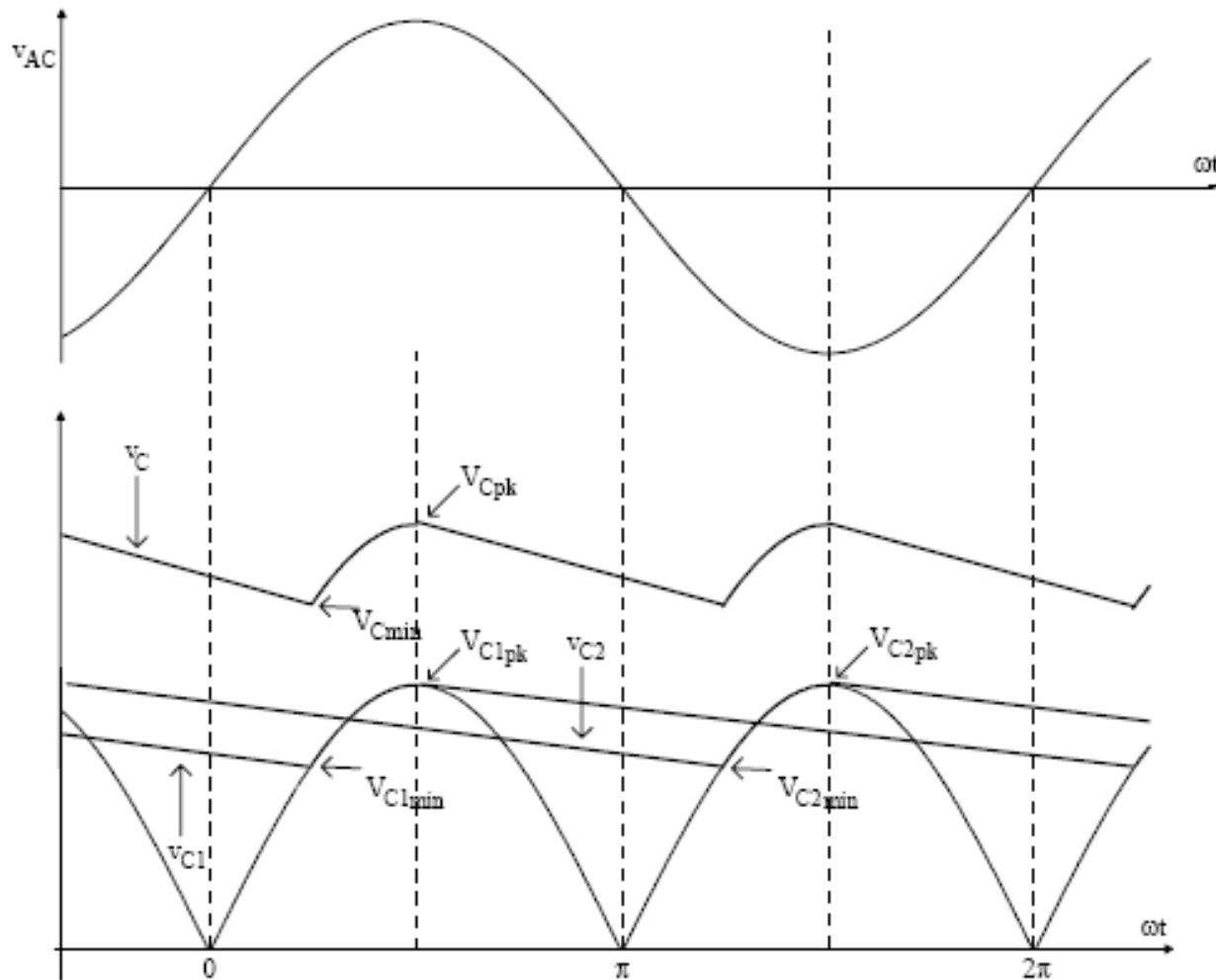

Retificadores e filtros capacitivos

Descrição do funcionamento:

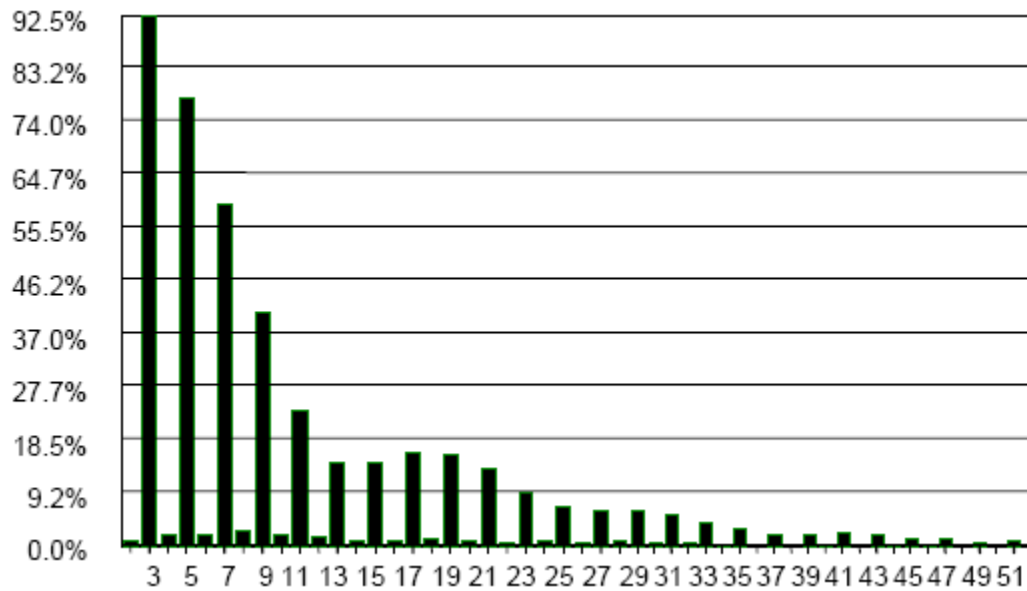
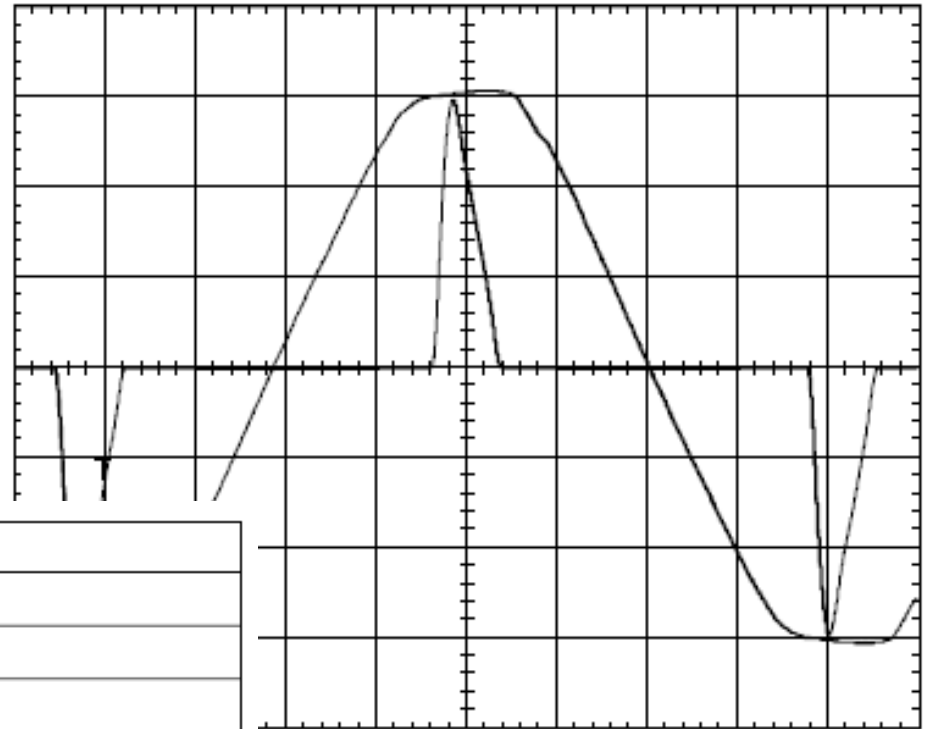

Retificadores e filtros capacitivos

Exemplo:

- Projetar um filtro capacitivo, dobrador de tensão para:
 - Operação em 110/220 V;
 - Frequência da rede de 60 Hz;
 - Corrente média na carga de 5 A;
 - Ondulação de tensão permitida na carga = 5%.



Reguladores lineares

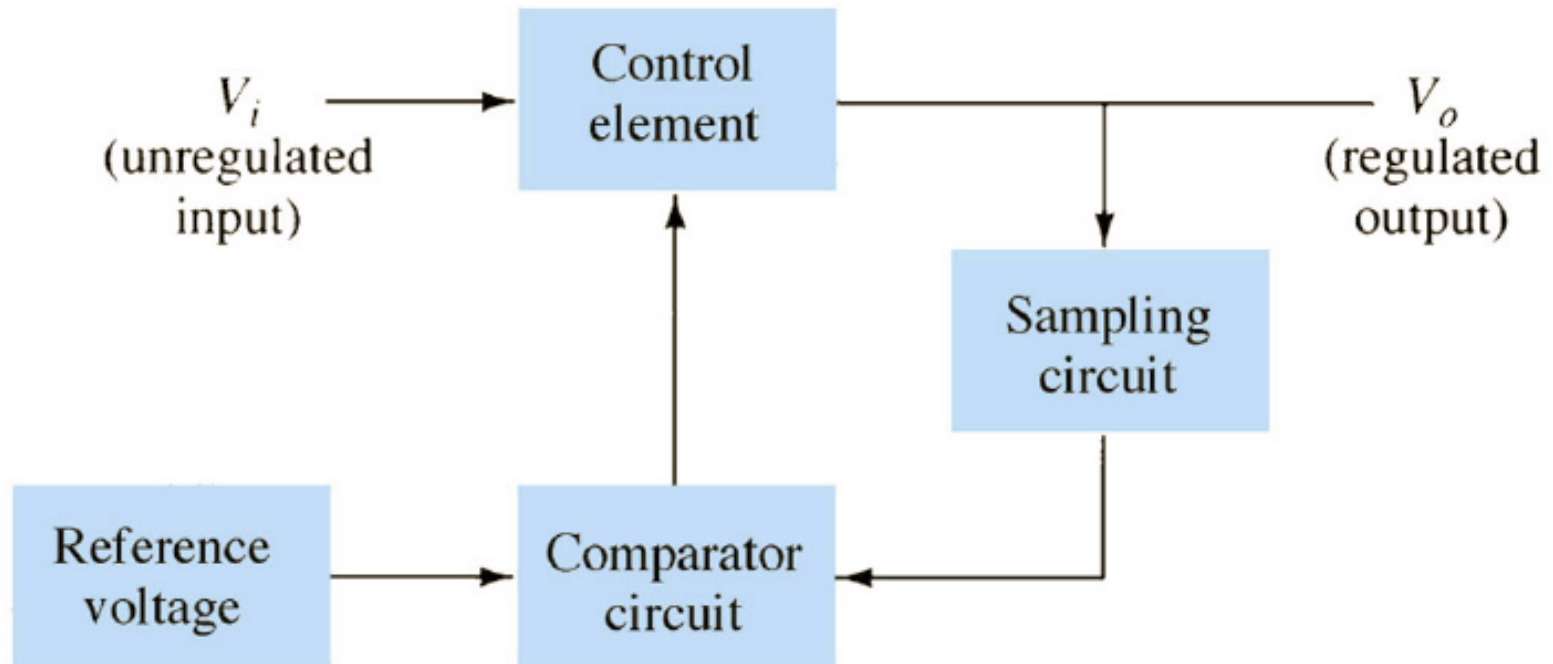

Princípio da regulação série.

Reguladores lineares

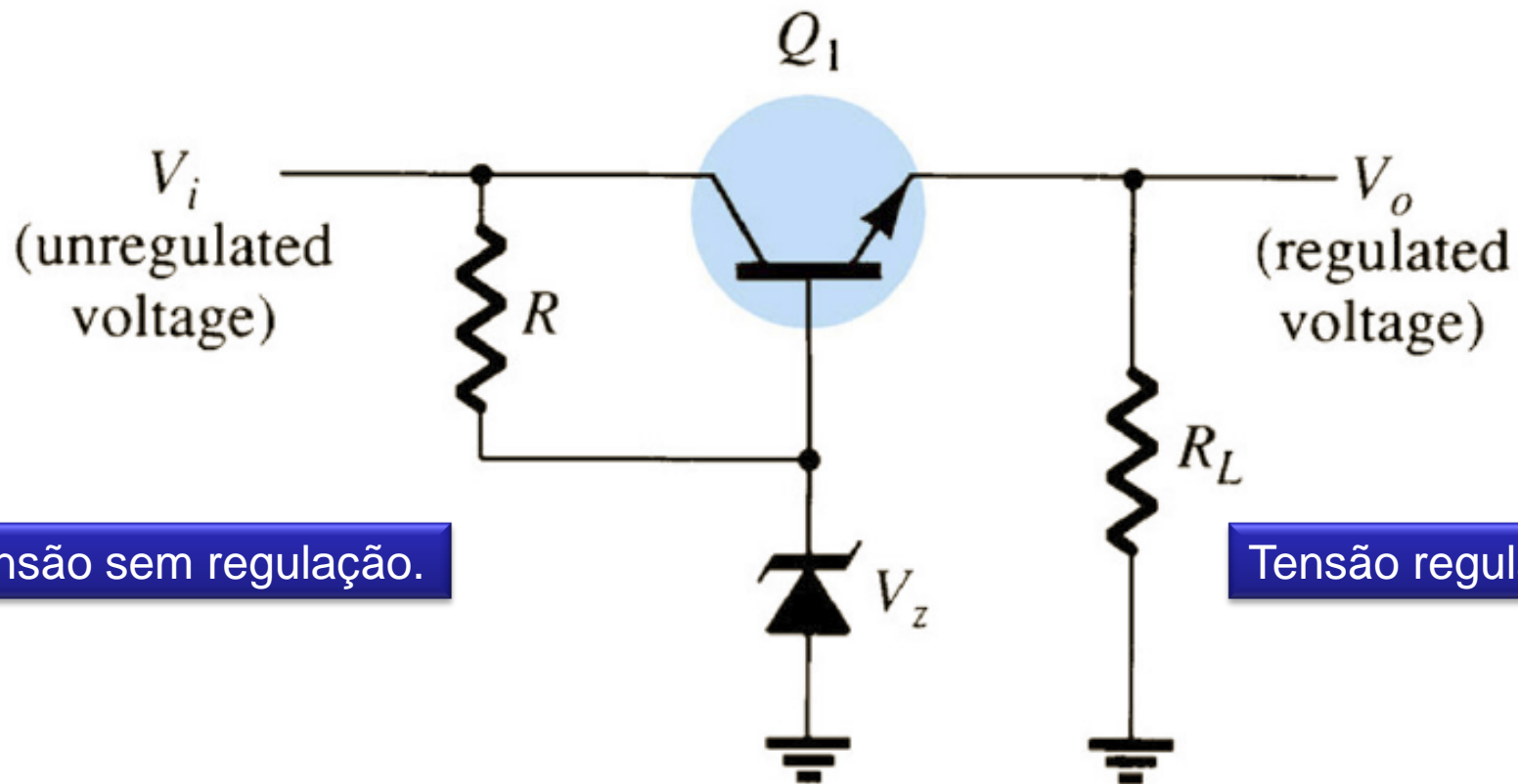

Tensão sem regulação.

Tensão regulada.

Reguladores lineares

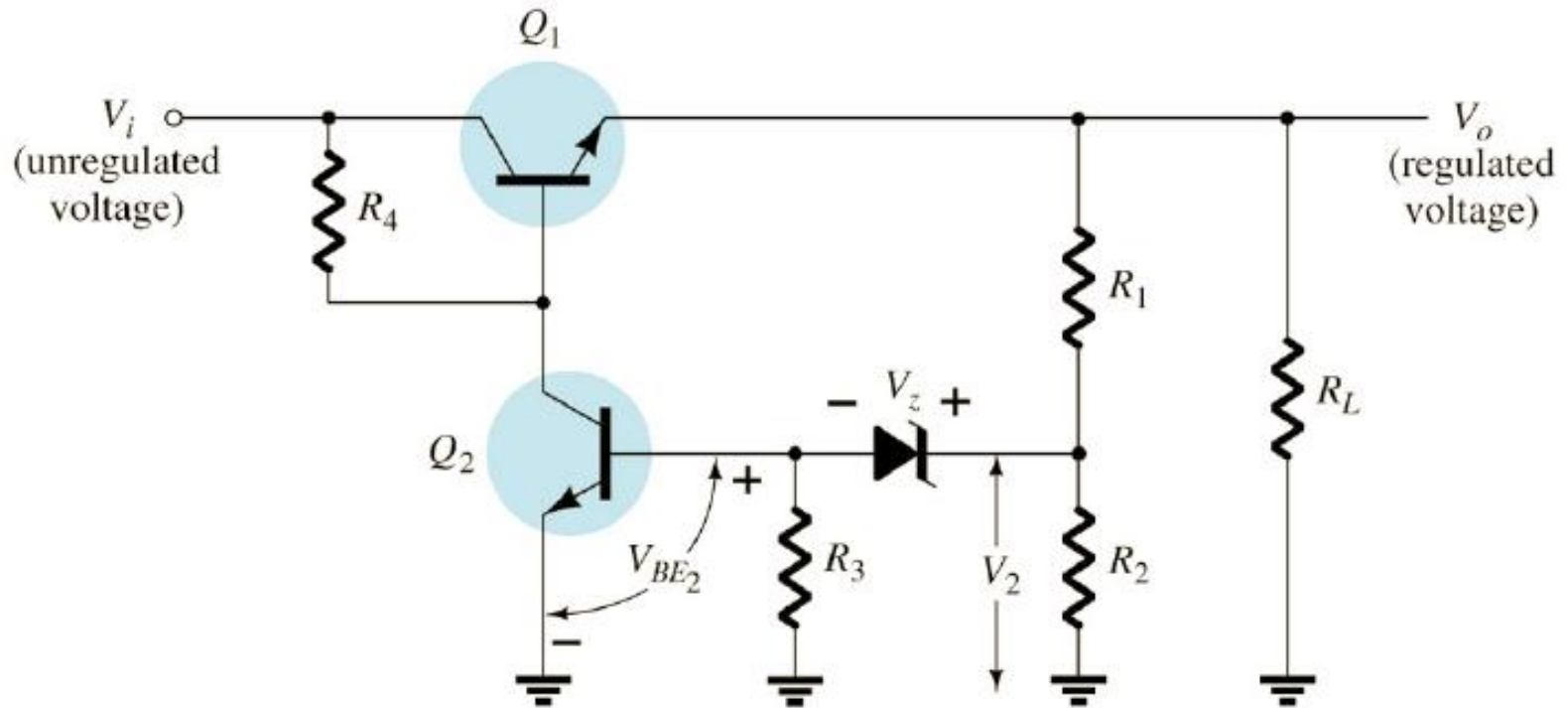

$$V_{BE2} + V_Z = V_2 = \frac{R_2}{R_1 + R_2} V_o$$

$$V_o = \frac{R_1 + R_2}{R_2} (V_Z + V_{BE2})$$

Reguladores lineares

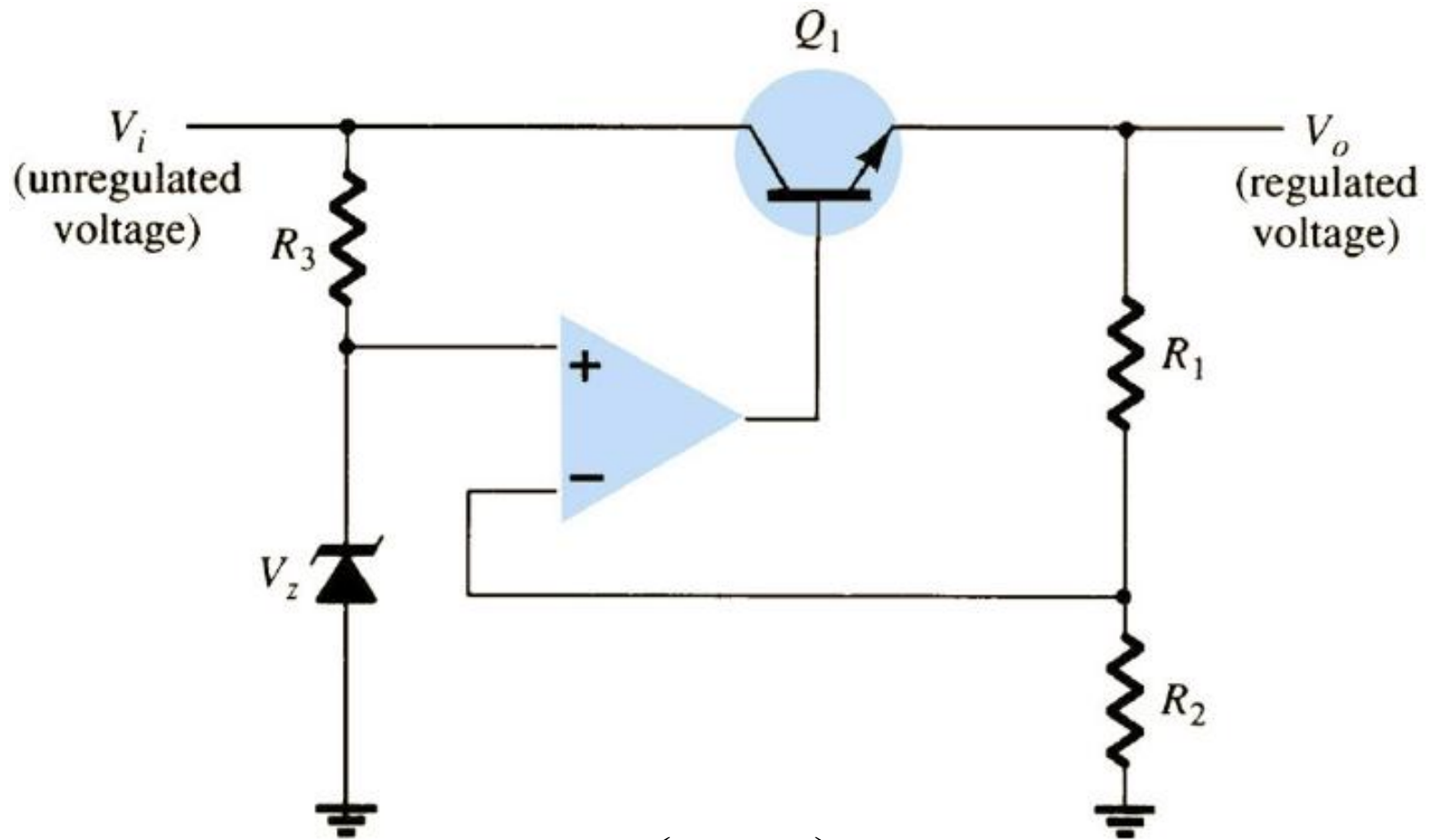

$$V_o = \left(1 + \frac{R_1}{R_2} \right) V_z$$

Reguladores lineares

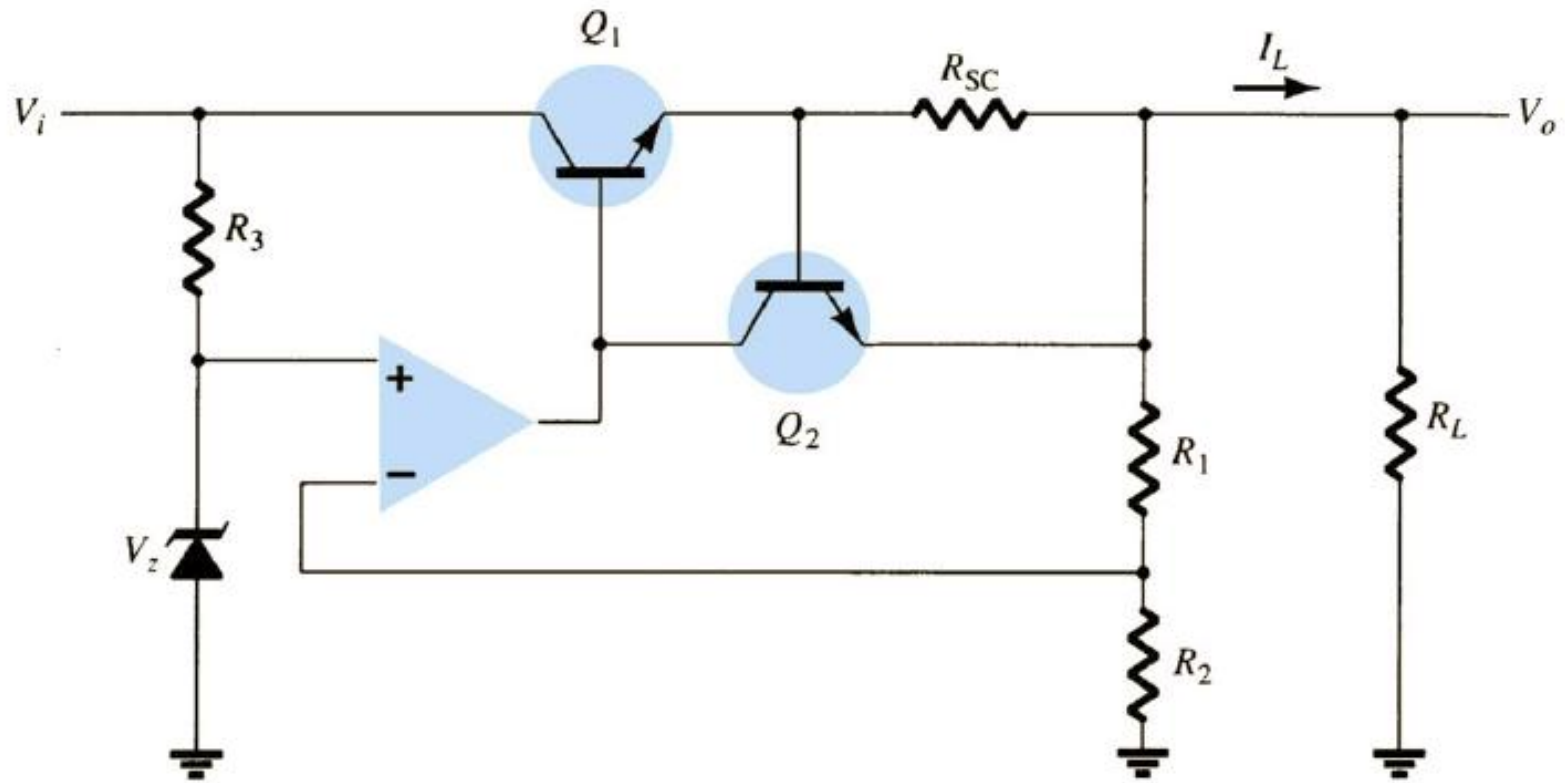

Limitação de corrente.

Reguladores lineares

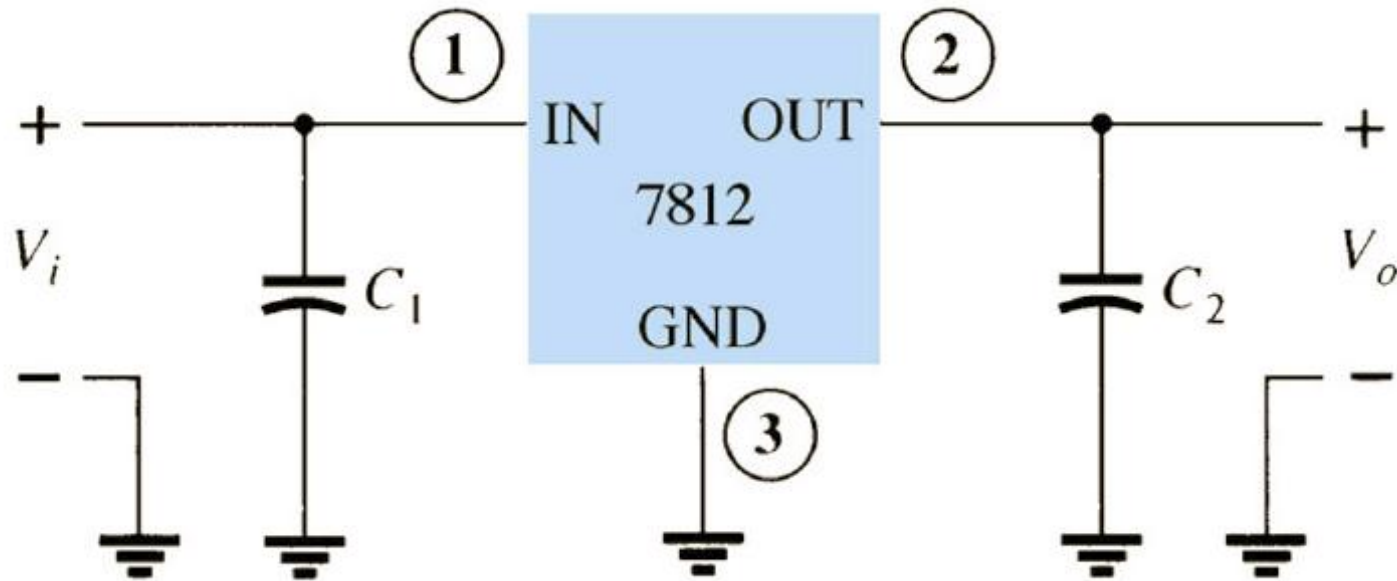

Código do CI	Tensão de saída (V)	Vi mínimo (V)
7805	+5	7,3
7806	+6	8,3
7808	+8	10,5
7810	+10	12,5
7812	+12	14,6
7815	+15	17,7
7818	+18	21,0
7824	+24	27,1

Reguladores lineares

LM79XX Series 3-Terminal Negative Regulators

General Description

The LM79XX series of 3-terminal regulators is available with fixed output voltages of $-5V$, $-8V$, $-12V$, and $-15V$. These devices need only one external component—a compensation capacitor at the output. The LM79XX series is packaged in the TO-220 power package and is capable of supplying 1.5A of output current.

These regulators employ internal current limiting safe area protection and thermal shutdown for protection against virtually all overload conditions.

Low ground pin current of the LM79XX series allows output voltage to be easily boosted above the preset value with a resistor divider. The low quiescent current drain of

these devices with a specified maximum change with I and load ensures good regulation in the voltage boost mode.

For applications requiring other voltages, see LM137 d sheet.

Features

- Thermal, short circuit and safe area protection
- High ripple rejection
- 1.5A output current
- 4% tolerance on preset output voltage

Connection Diagrams

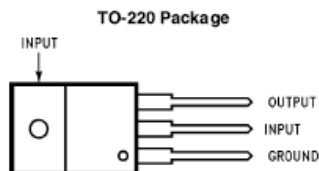

Order Number LM7905CT, LM7912CT or LM7915CT
See NS Package Number TO3B

TL/H/7340-14

Typical Applications

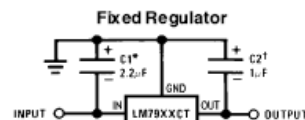

*Required if regulator is separated from filter capacitor more than 3". For value given, capacitor must be solid tantalum. 25 μF aluminum electrolytic may be substituted.

†Required for stability. For value given, capacitor must be solid tantalum. 25 μF aluminum electrolytic may be substituted. Values given may be increased without limit. For output capacitance in excess of 100 μF , a fast diode from input to output (1N4001, etc.) will protect regulator from momentary input shorts.

Fixed Regulator

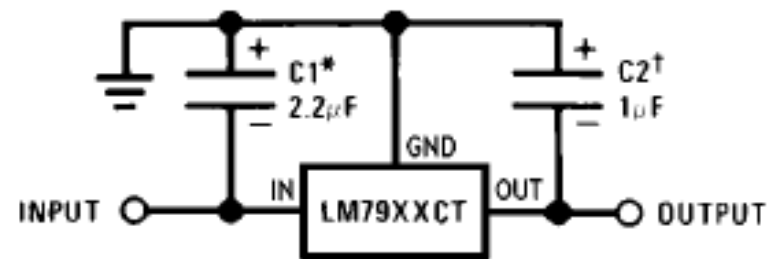

Código do CI	Tensão de saída (V)	V_i mínimo (V)
7905	-5	-7,3
7906	-6	-8,4
7908	-8	-10,5
7909	-9	-11,5
7912	-12	-14,6
7915	-15	-17,7
7918	-18	-20,8
7924	-24	-27,1

Reguladores lineares

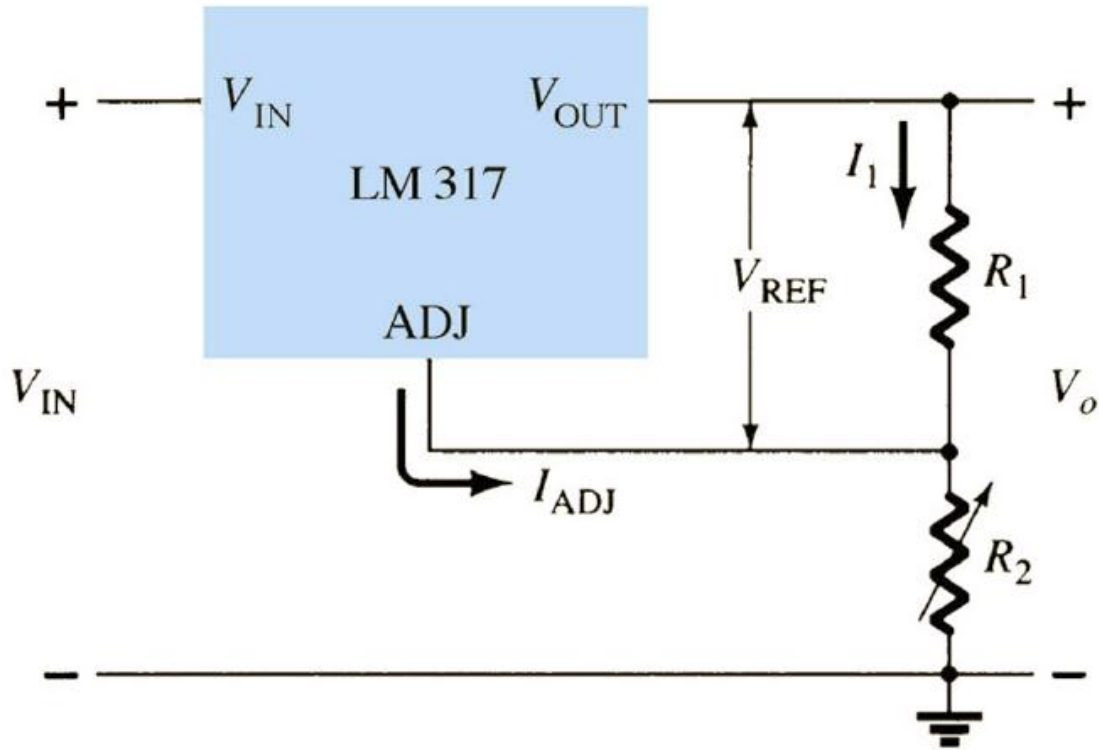

$$V_{ref} = 1,25V$$

$$I_{ADJ} = 50 \text{ ou } 100 \mu A$$

$$V_o = V_{ref} \left(1 + \frac{R_2}{R_1} \right) + I_{ADJ} \cdot R_2$$

Reguladores lineares

The image shows a screenshot of the Fairchild Semiconductor website in Internet Explorer. The browser address bar shows <http://www.fairchildsemi.com/>. The website features a navigation menu with the following categories:

- PRODUCTS & SAMPLES
 - POWER MANAGEMENT ICs
 - AC-DC: Power Factor Correction
 - Isolated DC-DC
 - Non-Isolated DC-DC
 - Power Drivers
 - Supervisory / Monitor ICs
 - Voltage Regulators
 - LDOs
 - Positive Voltage Linear Regulators
 - Negative Voltage Linear Regulators
 - Shunt Regulators
 - POWER SEMICONDUCTORS
 - Diodes & Rectifiers
 - IGBTs
 - Integrated Power Solutions
 - MOSFETs
 - Transistors
 - TRIACs
- OPTOELECTRONICS
 - Infrared
 - High Performance Optocoupler
 - TRIAC Driver Optocoupler
 - Photo Transistor
 - Solid State Relay
- LOGIC | TINYLOGIC
 - Click to view
- LIGHTING & DISPLAY
 - Click to view
- AUTOMOTIVE PRODUCTS
 - Discrete Power
 - Intelligent Power

A callout box on the right side of the page displays the expanded 'Voltage Regulators' menu:

- Voltage Regulators
 - LDOs
 - Positive Voltage Linear Regulators
 - Negative Voltage Linear Regulators
 - Shunt Regulators

The callout box also includes a small graph showing 'Efficiency' on the y-axis (ranging from 70 to 80) and 'Load Current (A)' on the x-axis. A data point on the graph is labeled '95% efficiency'. A black arrow points from the 'Voltage Regulators' menu item in the main navigation to the callout box.

<http://www.fairchildsemi.com>

Reguladores lineares

FAIRCHILD
SEMICONDUCTOR®

www.fairchildsemi.com

KA78RXXC-Series 1A Output Low Dropout Voltage Regulators

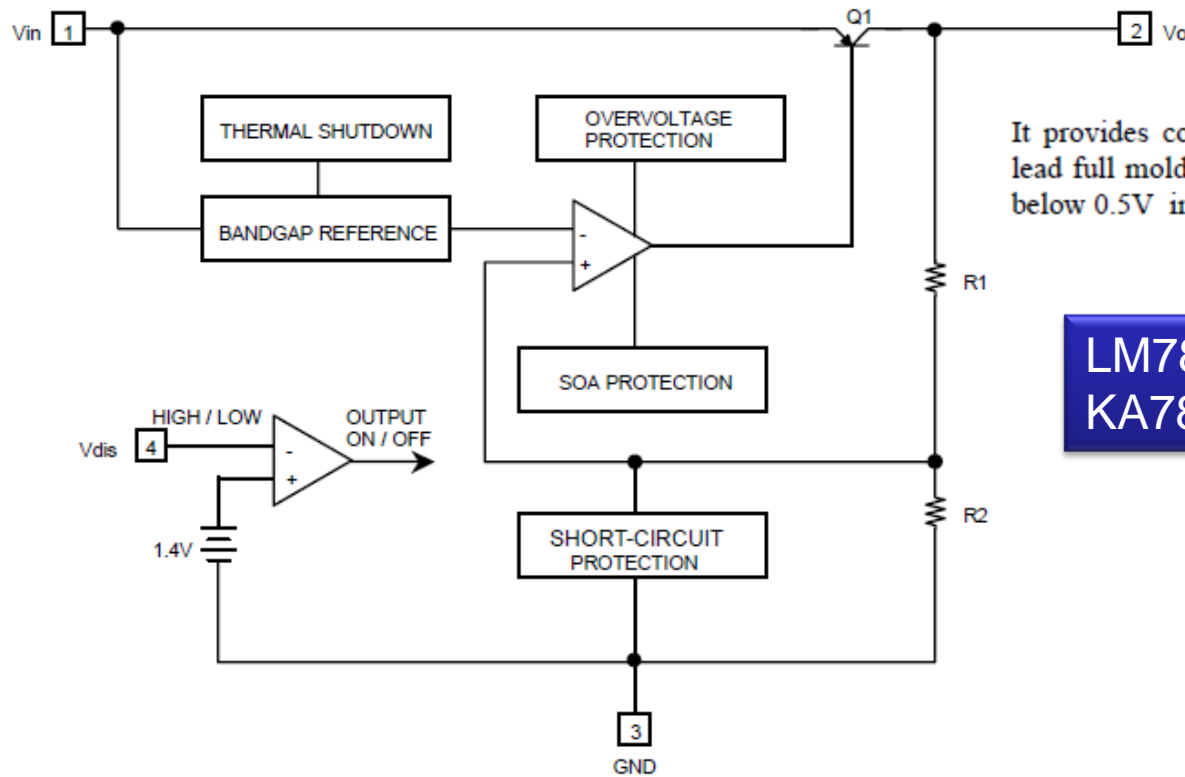
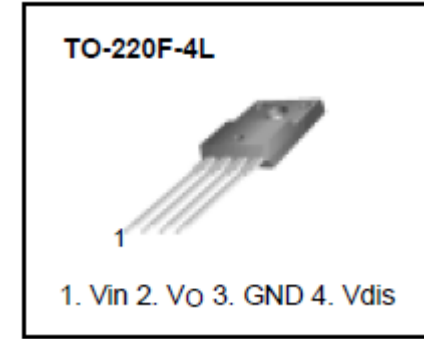

It provides constant voltage power source with TO-220-4 lead full mold package. Dropout voltage of KA78RXXC is below 0.5V in full rated current(1A).

LM7805 = R\$ 1,05
KA78R05 = R\$ 1,71

Inrush

O problema:

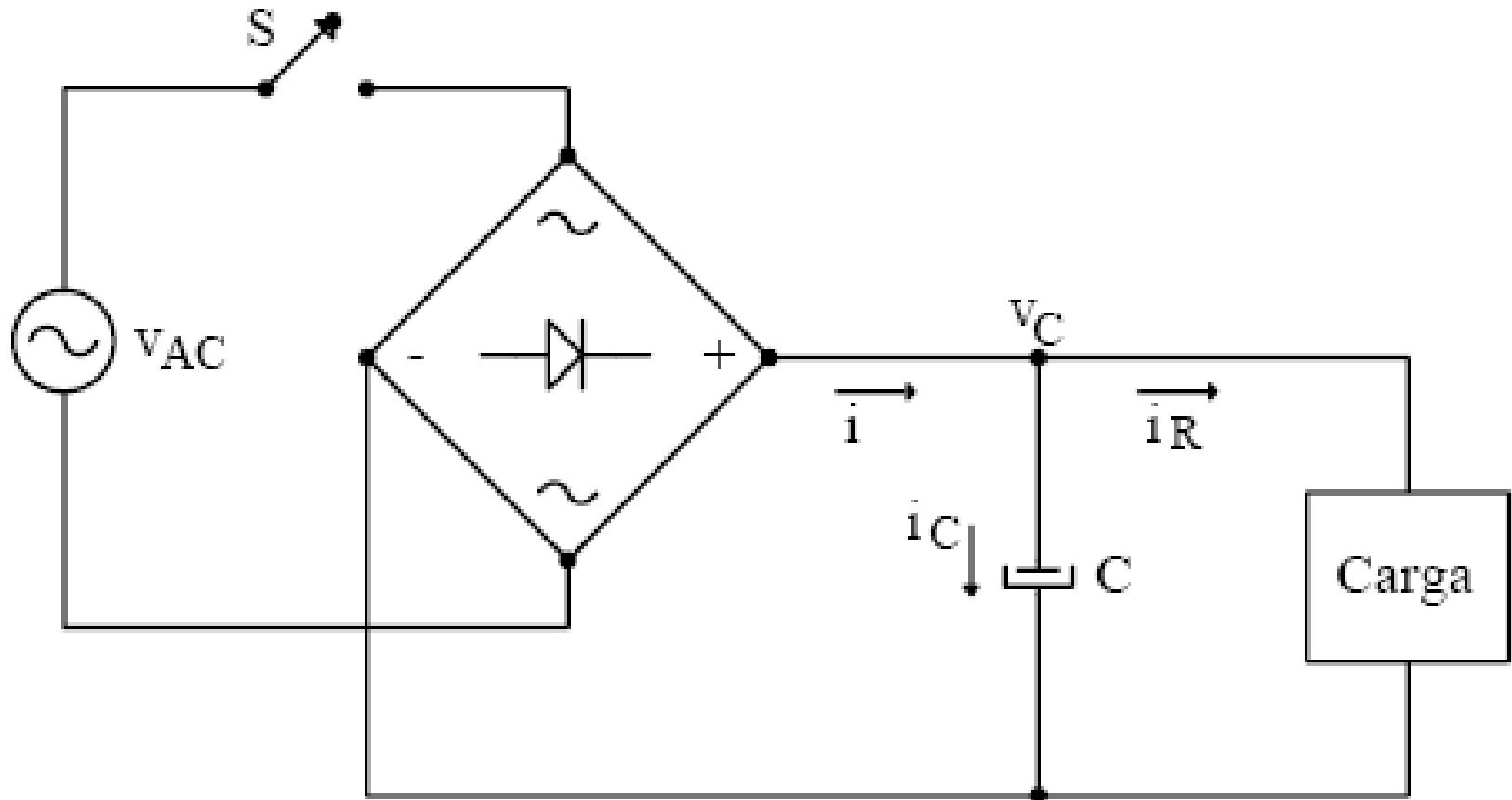

Inrush

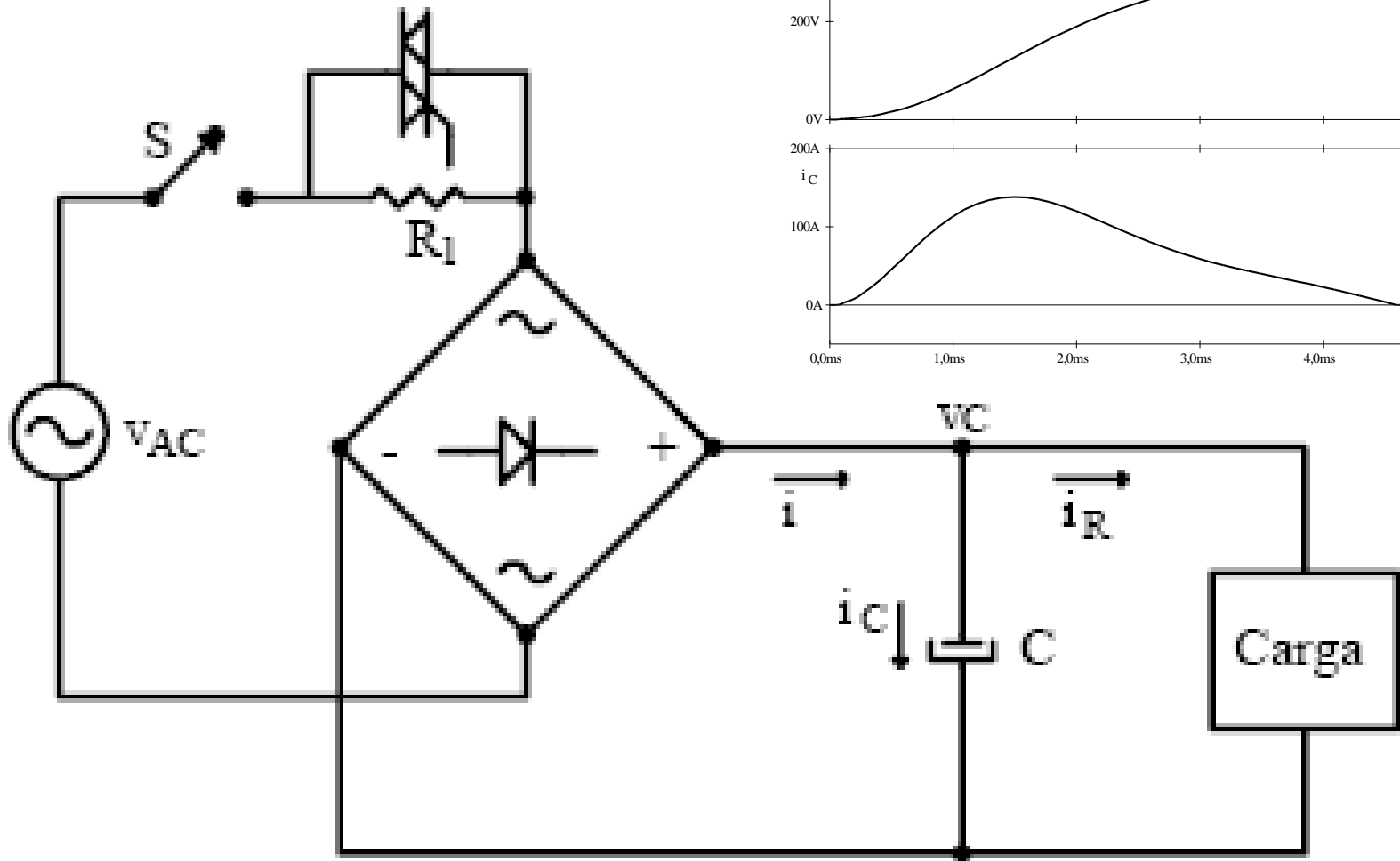

Inrush

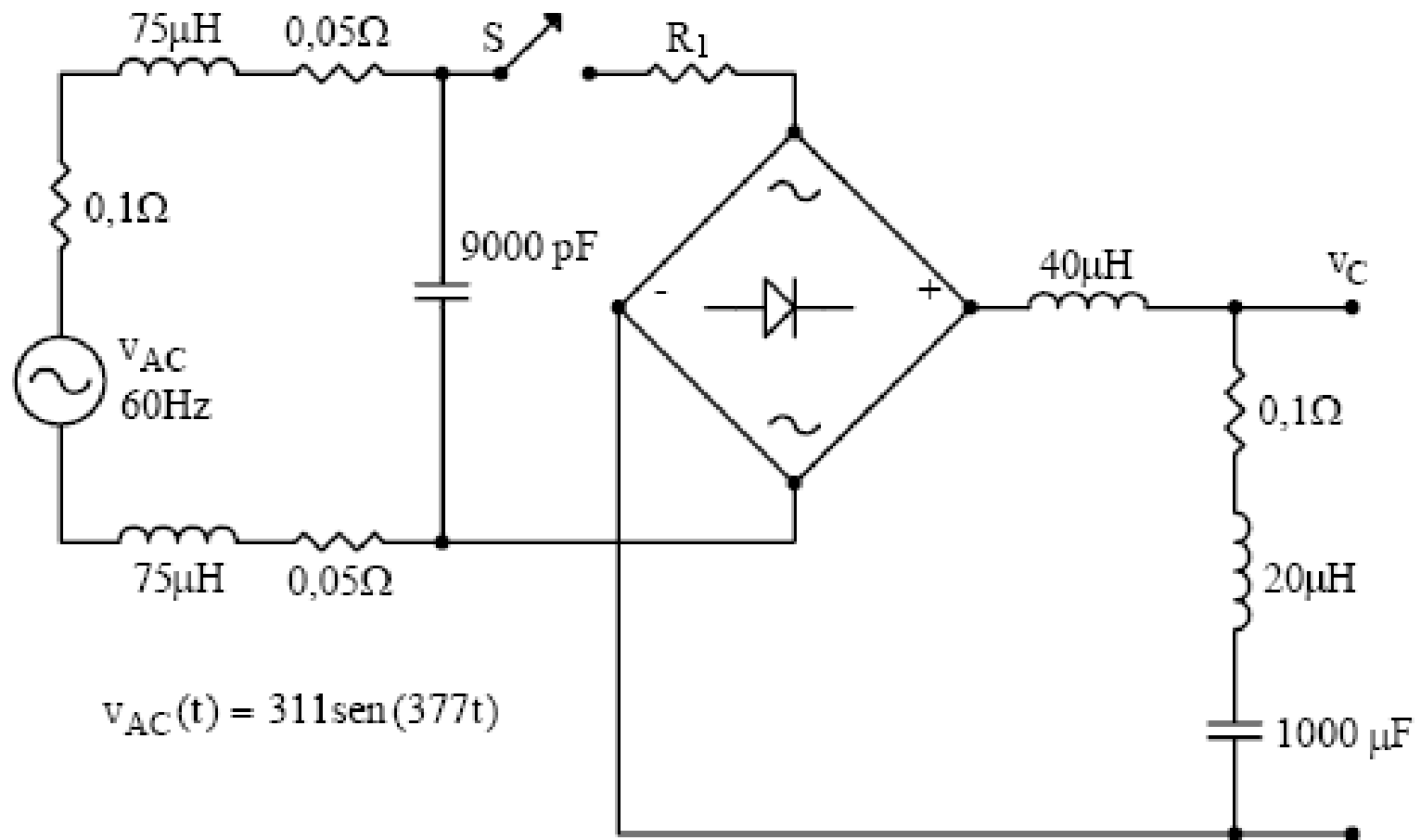

Inrush

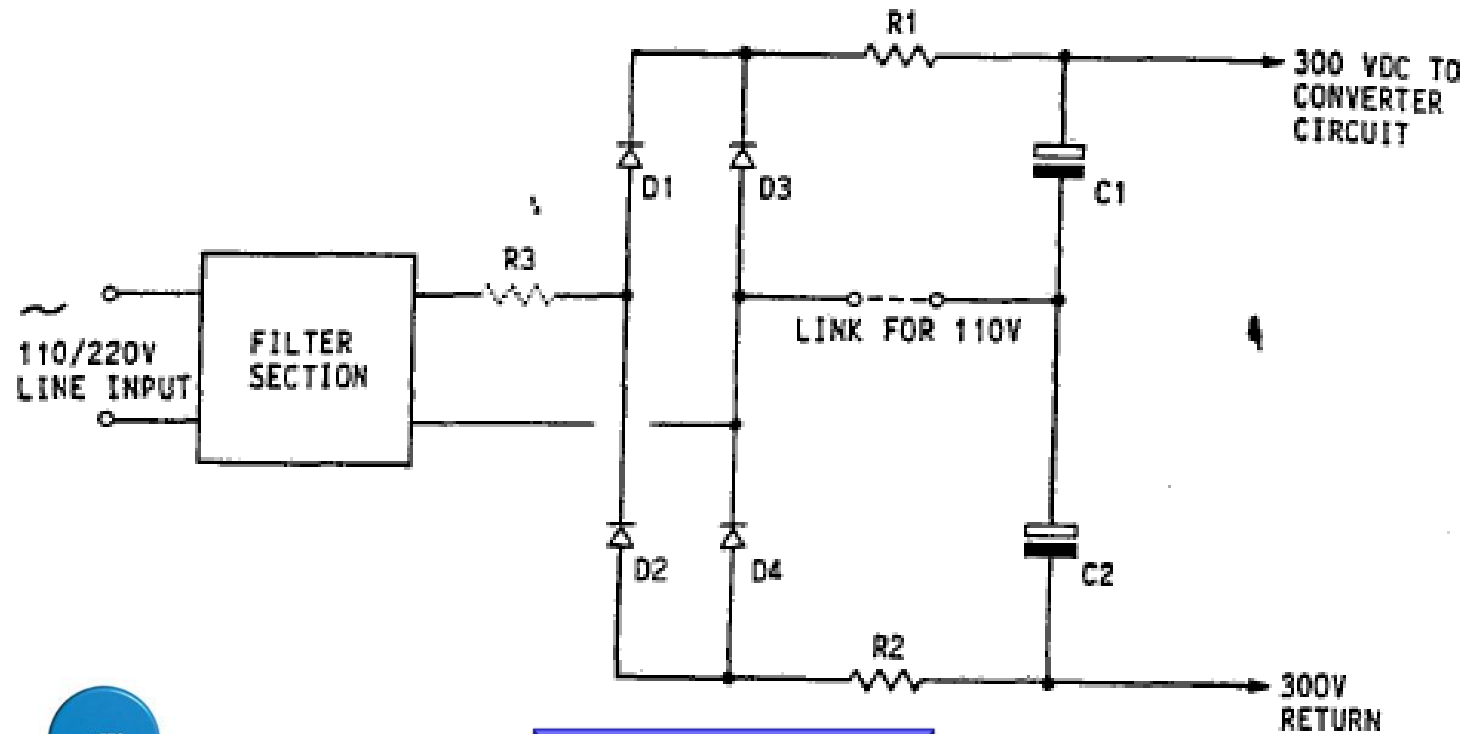

Resistores série



Inrush

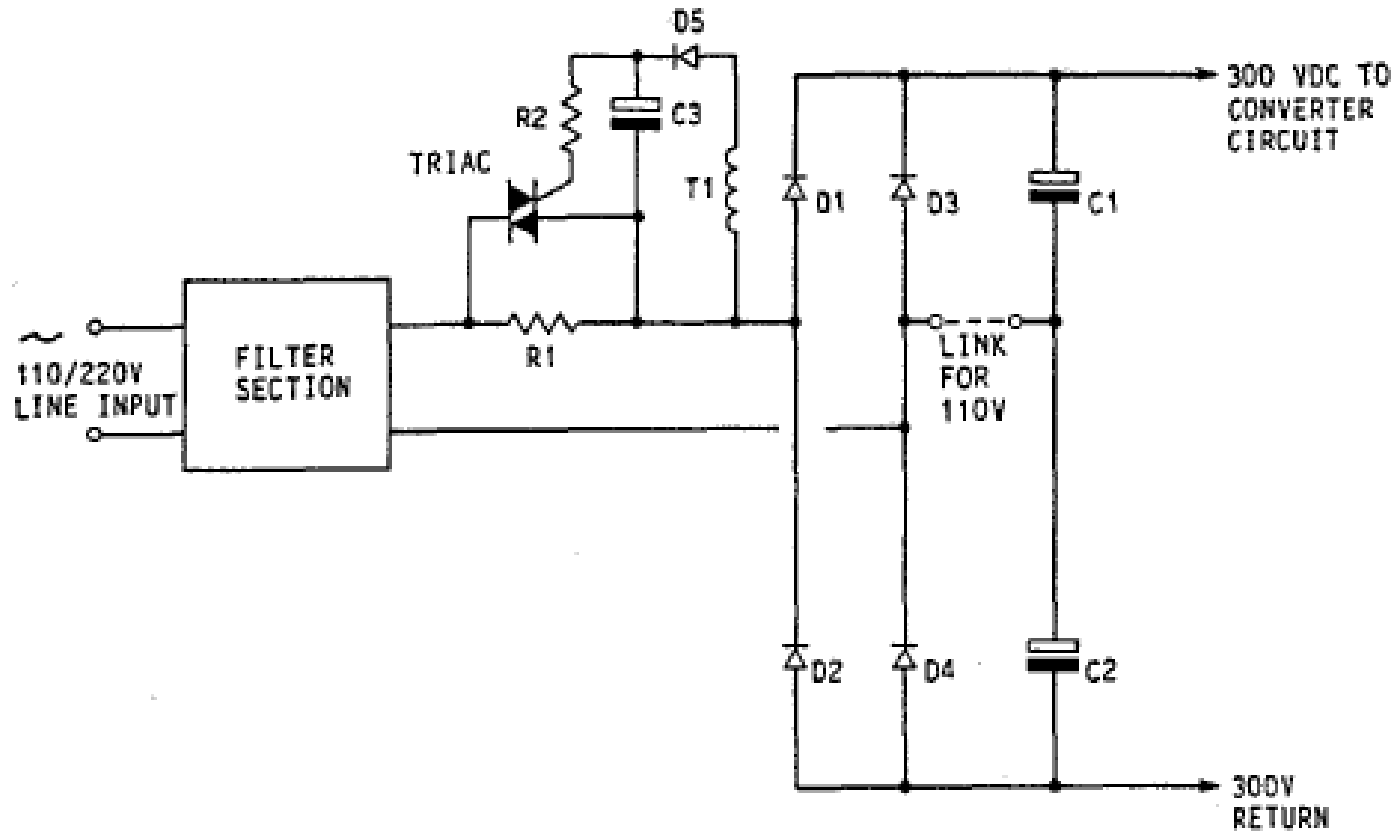

Resistores série temporariamente

Inrush

Exemplo:

- Projetar um circuito de limitação de corrente para:
 - Diodos retificadores 1N4007;
 - Capacitor de filtro de 4700 μF ;
 - Considerar resistência da rede nula.



Circuitos de partida

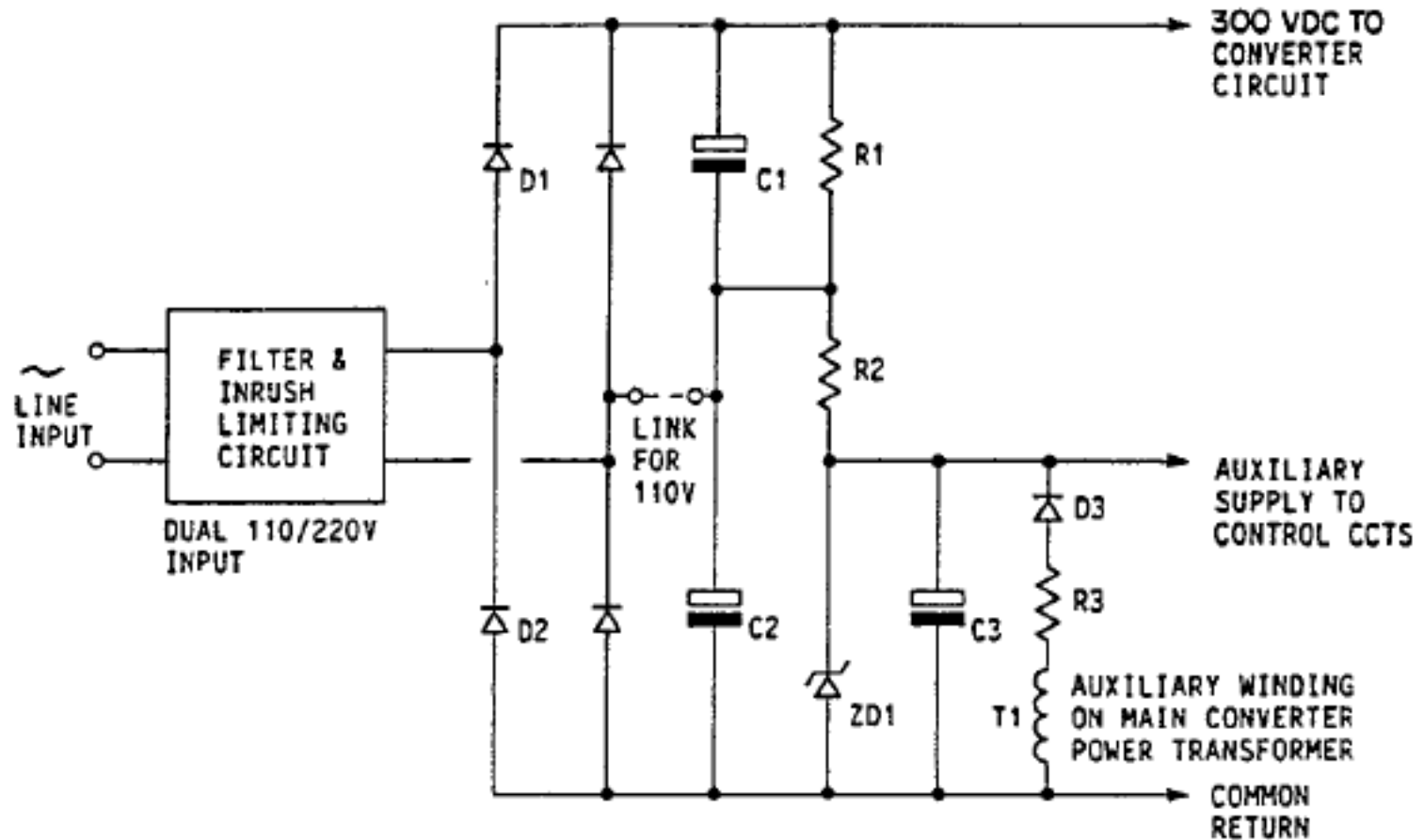

Circuito resistivo dissipativo

Circuitos de partida

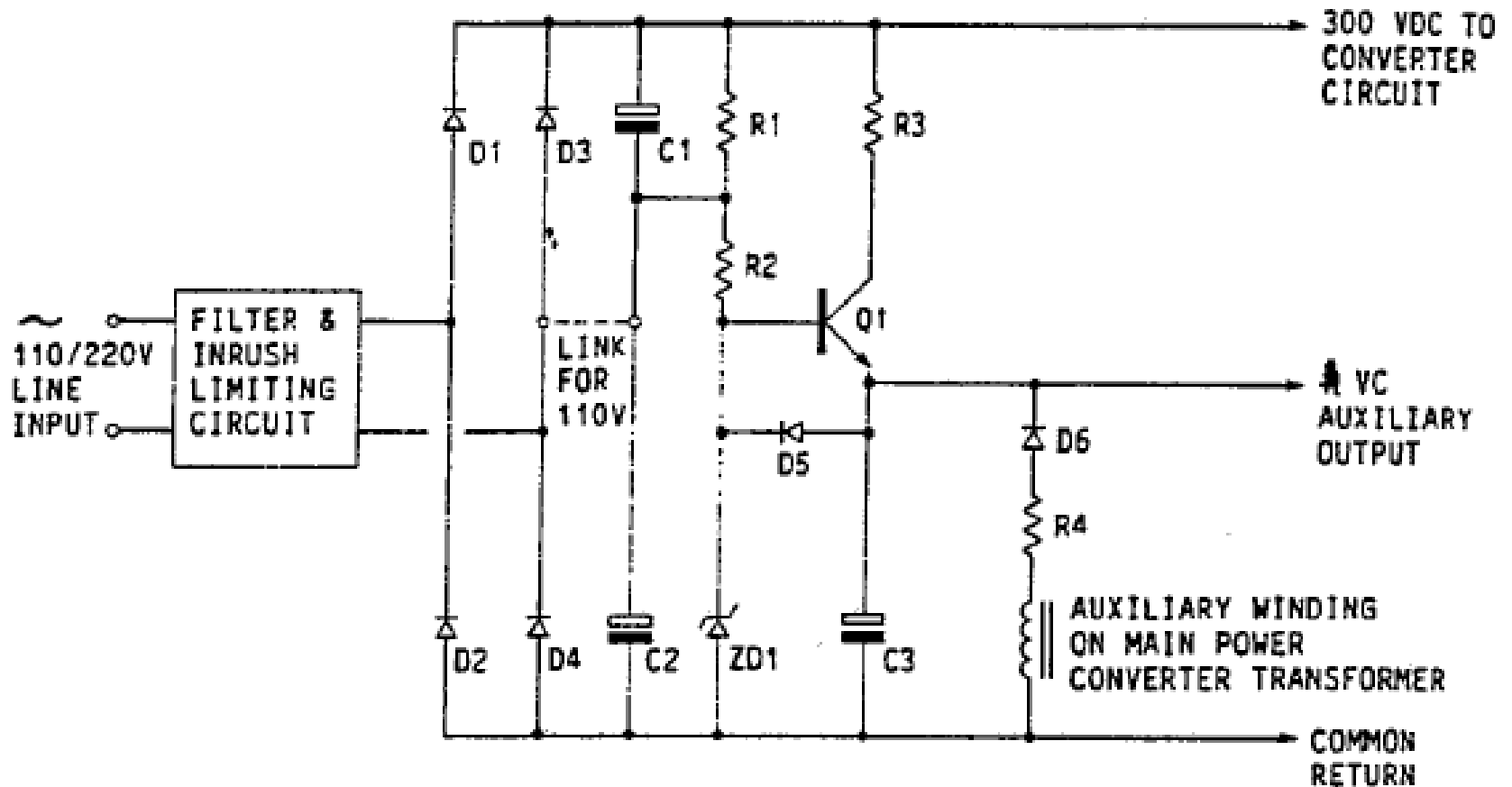

Circuito ativo

Circuitos de partida

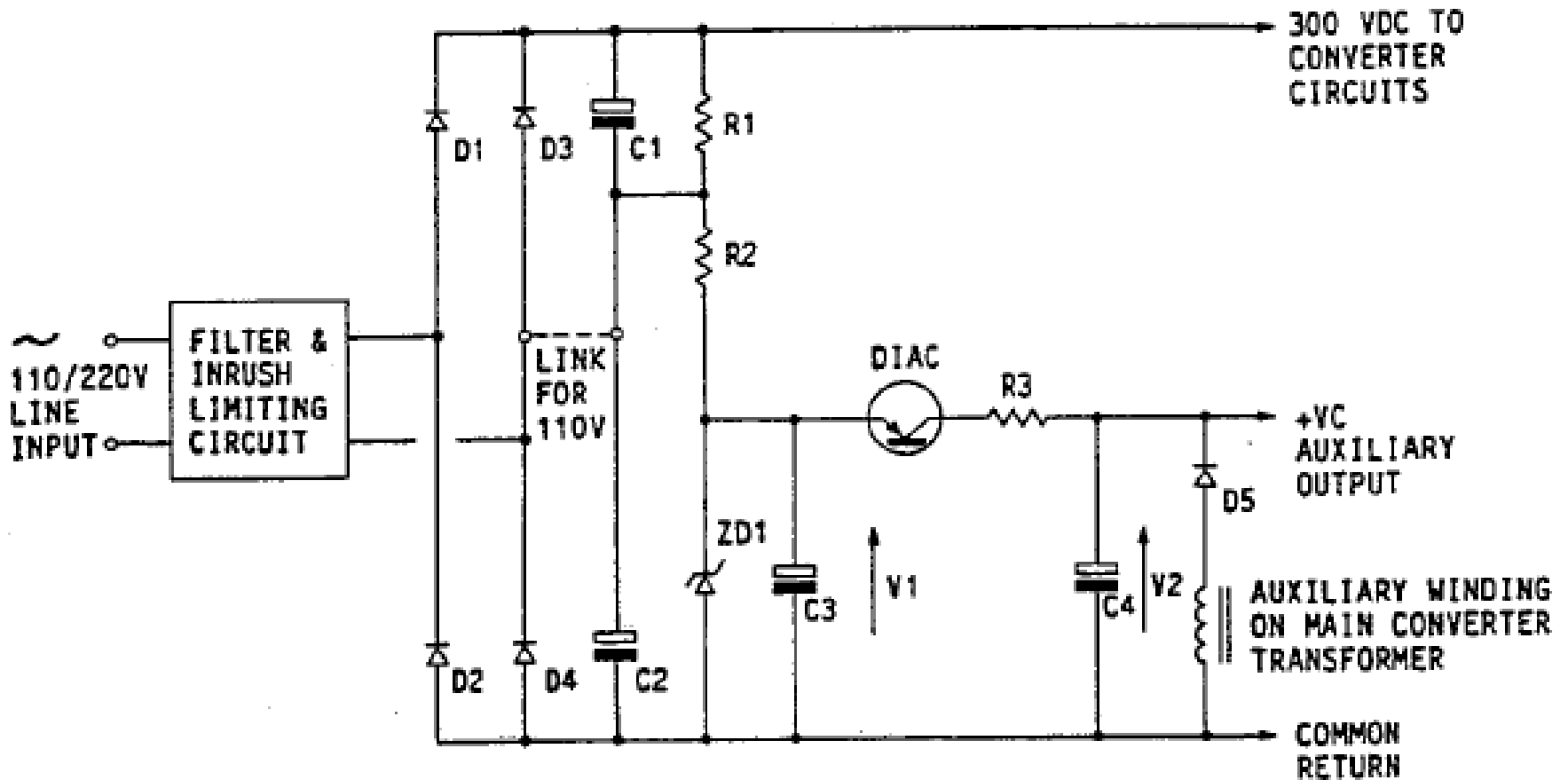

Circuito impulsivo

Próxima aula

Parte 1 – Fontes lineares:

1. Projeto de magnéticos;
2. Projeto térmico;
3. PCBs e layout;
4. Proteções.