

**Instituto Federal de Educação, Ciência e Tecnologia de Santa Catarina**

**Departamento Acadêmico de Eletrônica**

**Projeto de Fontes Chaveadas**

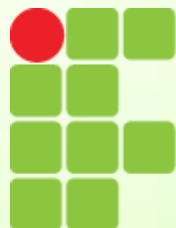

**INSTITUTO FEDERAL  
SANTA CATARINA**

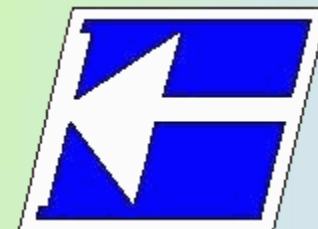

## **Parte 2 – Fontes Mistas**

**Modelagem de conversores estáticos**

**Controle de conversores estáticos**

**Prof. Clóvis Antônio Petry.**

**Florianópolis, abril de 2009.**

# Bibliografia para esta aula

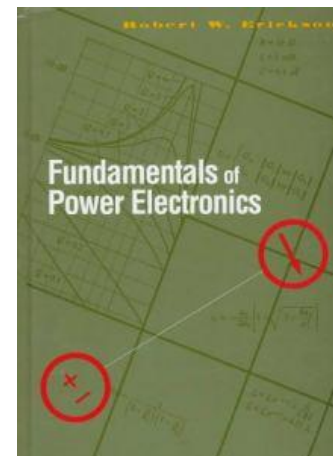
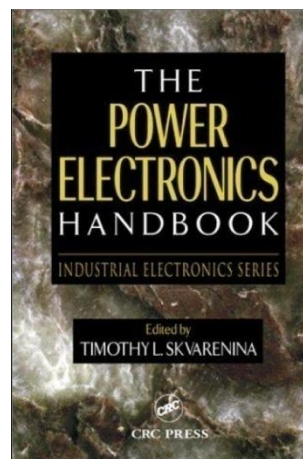

# Nesta aula

## **Parte 2 – Fontes mistas:**

1. Modelagem do conversor Buck para controle em malha fechada.
2. Controle em malha fechada do conversor Buck.

# Nesta aula

## **Conversores CC-CC – Modelagem de pequenos sinais do conversor Buck:**

1. Introdução;
2. Modelagem do conversor Buck;
3. Modelagem do filtro de saída;
4. Modelo do conversor completo;
5. Verificação das funções de transferência.

## **Conversores CC-CC – Controle em malha fechada do conversor Buck:**

1. Introdução;
2. Funções de transferência;
3. Metodologia de projeto do controlador;
4. Verificação por simulação.

# Operação em malha aberta x malha fechada

## **Operação em malha aberta:**

- Circuitos simples;
- Geralmente sem problemas de estabilidade;
- Erros estáticos (de regime) grandes;
- Respostas transitórias com sobresinal;
- Projeto simples;
- Conformação de sinais complicada.

## **Operação em malha fechada:**

- Circuitos mais complexos;
- Podem apresentar problemas de estabilidade;
- Erros estáticos praticamente nulos;
- Melhora da resposta transitória;
- Projeto complexo;
- Possibilidade de conformar sinais.

# Diagrama de blocos do conversor

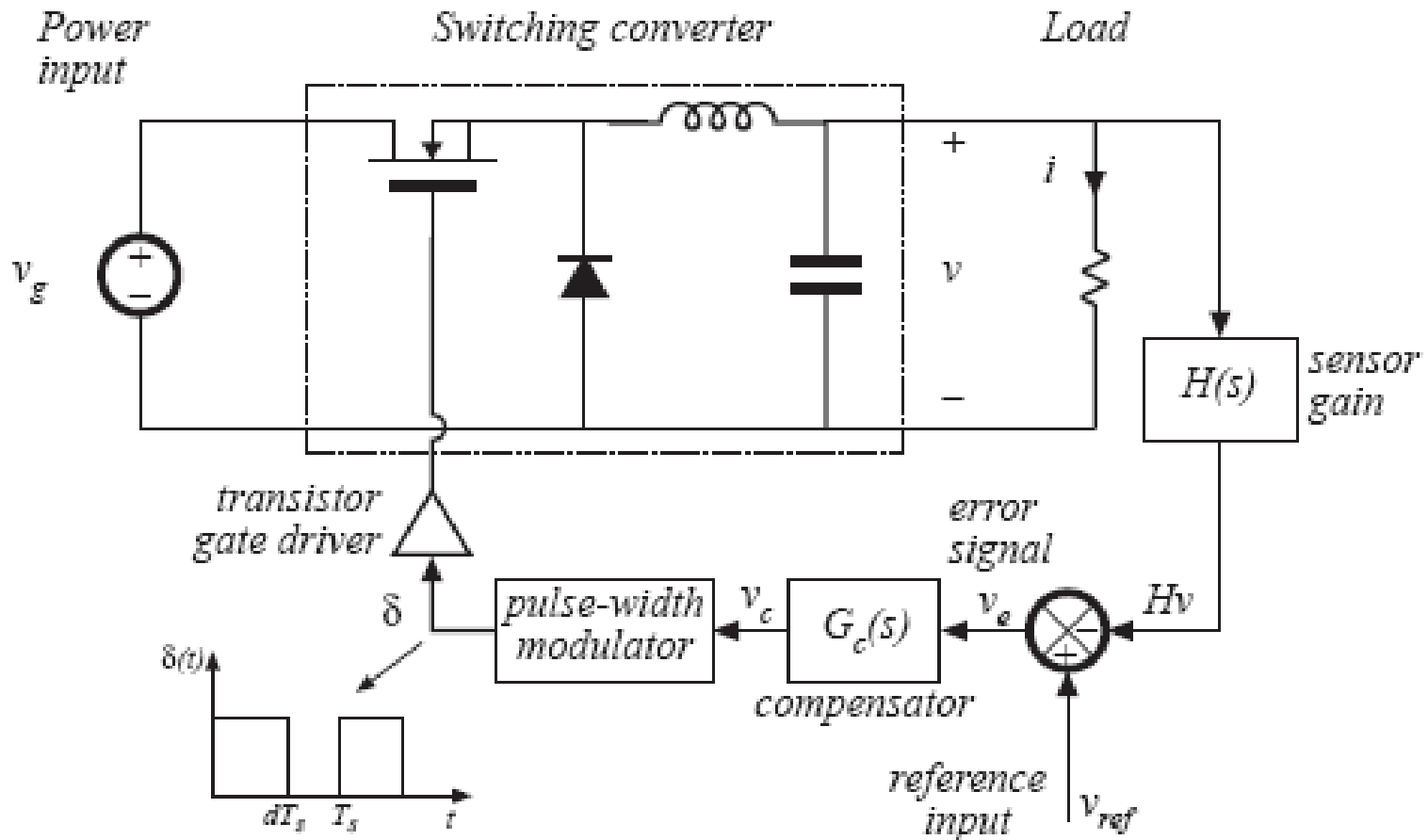

# Diagrama de blocos do conversor

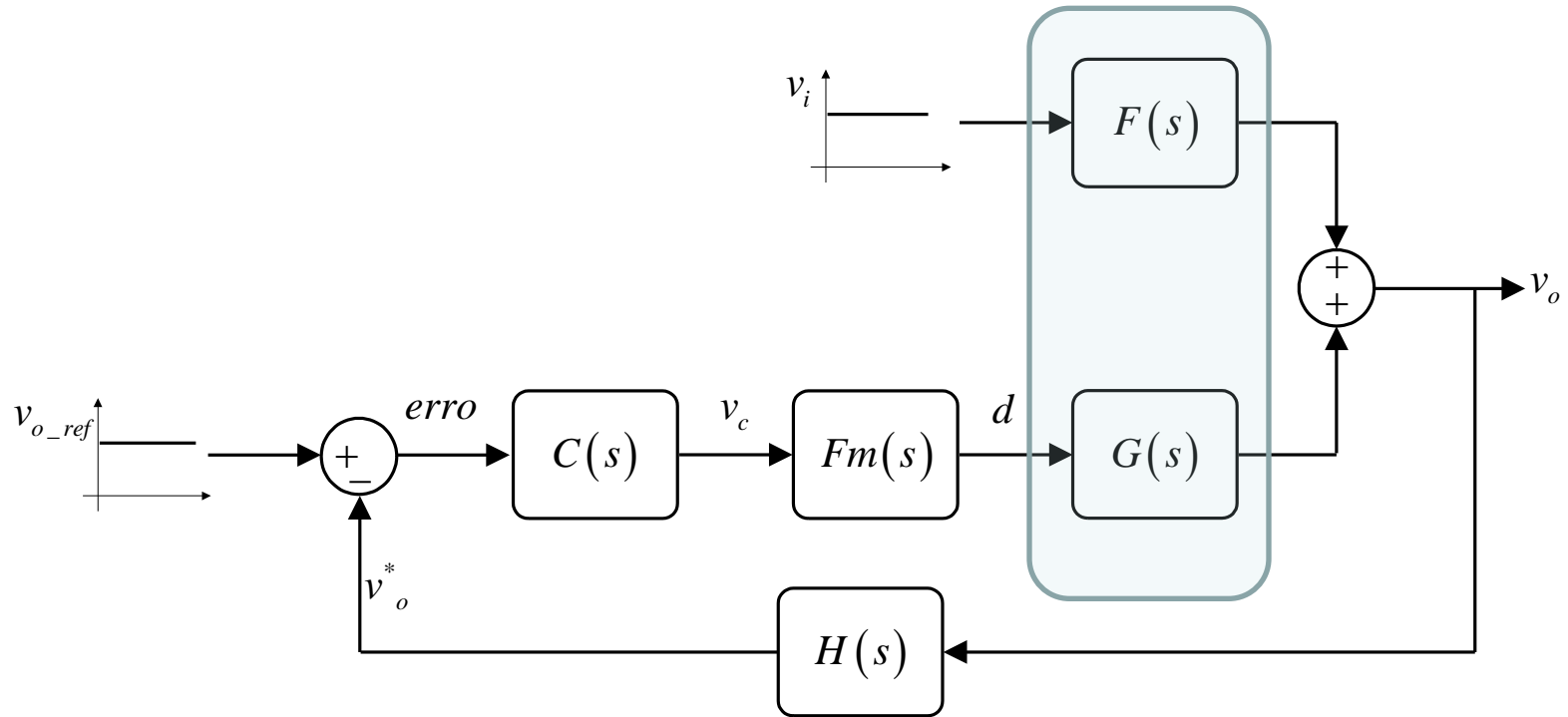

$$F(s) = \left. \frac{v_o(s)}{v_i(s)} \right|_{\hat{d} = 0}$$

$$G(s) = \left. \frac{v_o(s)}{d(s)} \right|_{\hat{v}_i = 0}$$

# Técnicas de controle de conversores

## **Principais técnicas de controle de conversores estáticos:**

- Técnicas lineares x não-lineares;
- Controle clássico x controle moderno;
- Controle no domínio do tempo x domínio da frequência;
- Controle por histerese;
- Controle fuzzy;
- Controle adaptativo;
- Controle por variáveis de estado;
- Controle por modos deslizantes;
- Entre outros.

# Controle por valores médios instantâneos

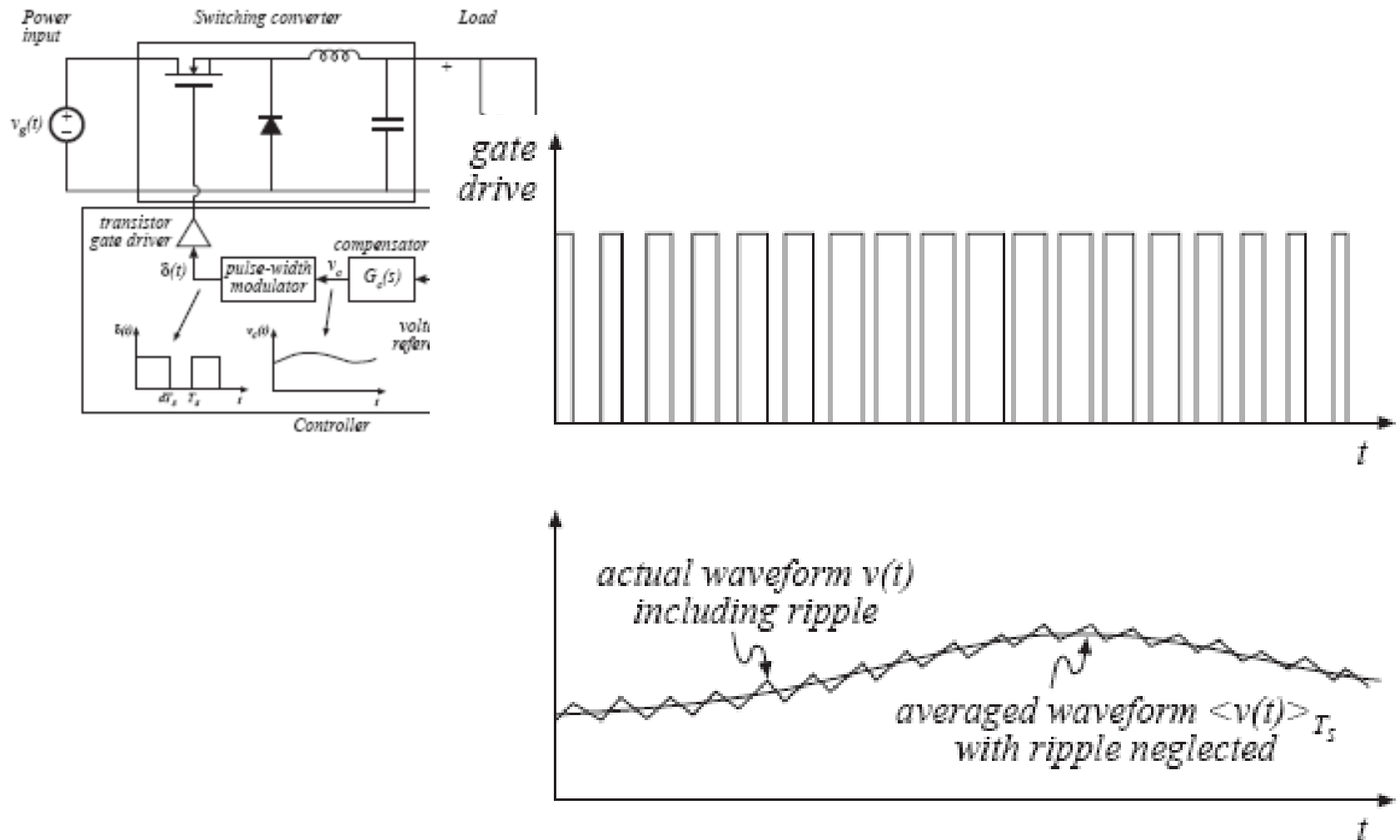

# Linearização nas proximidades do ponto de operação

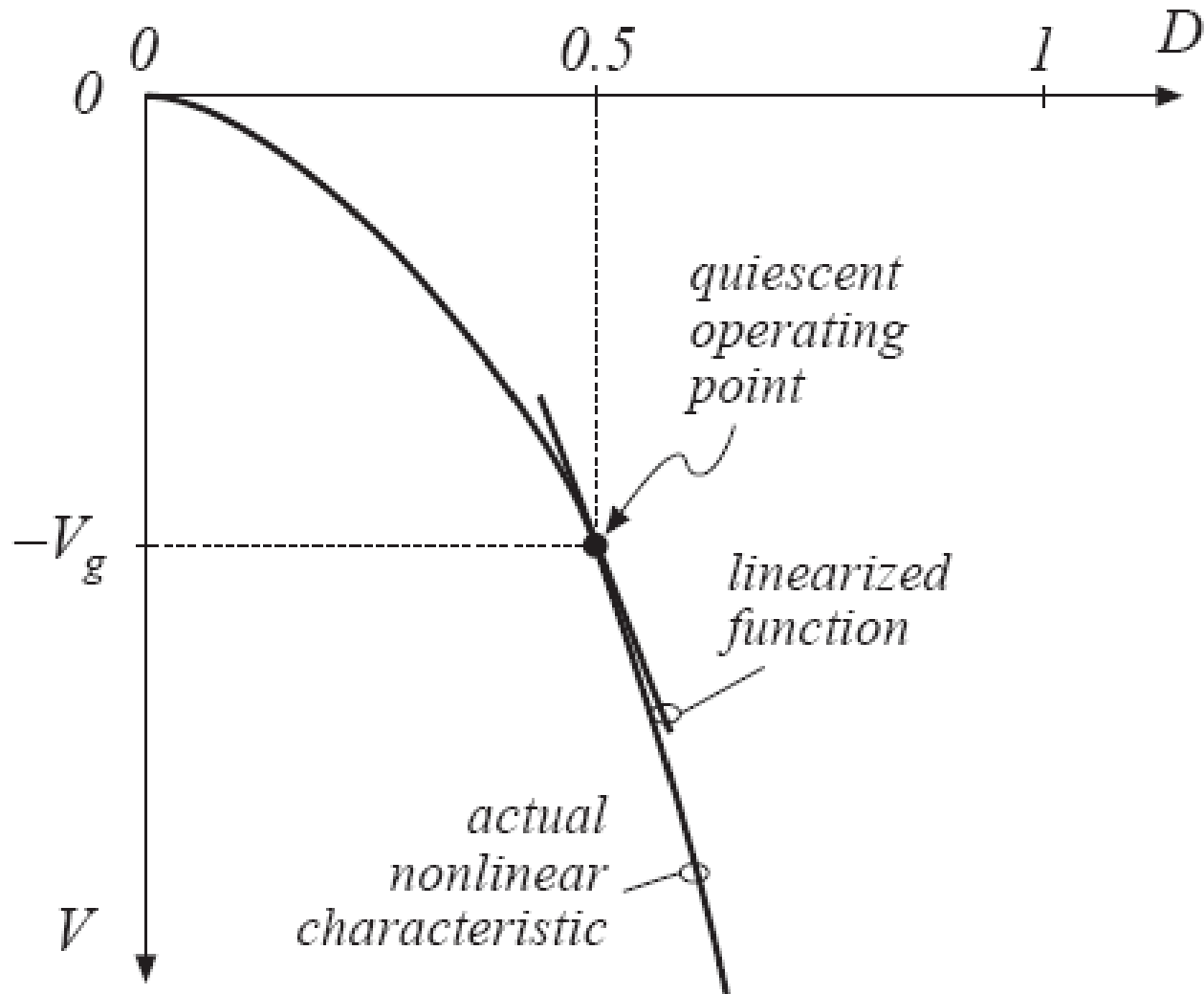

# Considerações para valores médios instantâneos

## **Controle no domínio da frequência:**

- Os componentes do conversor são considerados invariantes no tempo;
- Resistores, indutores e capacitores, bem como os interruptores passivos e ativos, são considerados ideais;
- As ondulações de corrente e de tensão são ignoradas na modelagem, isto é, o conversor é considerado linear e não chaveado;
- A frequência de operação é fixa;
- O conversor opera no modo de condução contínua;
- São válidos os princípios de linearidade e superposição.

# Modelo da chave PWM de Vorpérian

## Simplified Analysis of PWM Converters Using Model of PWM Switch Part I: Continuous Conduction Mode

VATCHÉ VORPÉRIAN  
Virginia Polytechnic Institute and State University

A circuit-oriented approach to the analysis of pulsewidth modulation (PWM) converters is presented. This method relies on the identification of a three-terminal nonlinear device, called the PWM switch, which consists of only the active and passive switches in a PWM converter. Once the invariant properties of the PWM switch are determined, an average equivalent circuit model for it can be derived. This model is versatile enough that it can easily account for storage-time modulation of BJTs. The dc and small-signal characteristics of a large class of PWM converters can then be obtained by a simple substitution of the PWM switch with its equivalent circuit model. The methodology presented is very similar to linear amplifier circuit analysis whereby the transistor is replaced by its equivalent circuit model. Consequently, for the novice, this method should serve as a very smooth introduction to the analysis of PWM converters.

Manuscript received February 16, 1989; revised June 16, 1989.

IEEE Log No. 33485A.

Author's address: Virginia Power Electronics Center, Dept. of Electrical Engineering, Virginia Polytechnic Institute and State University, Blacksburg, VA 24061.

0893-9213/90/0400-0490 \$1.00 © 1990 IEEE.

### INTRODUCTION

In this article the concept of the pulsewidth modulation (PWM) switch is introduced which leads to considerable simplification in the analysis (linear and nonlinear) and generation of dc-to-dc converters. To show the simplicity and elegance of the PWM switch model the dc and small-signal analysis of basic dc-to-dc converters is given. Of course, the results of the dc and small-signal analysis of dc-to-dc PWM converters are well known today from the systematic method of state-space averaging and its canonical circuit model [1, 2]. Hence, before going any further, a brief description of the two models mentioned above is given and the difference in the analytical approach between them is explained in order to justify the purpose of this article. First, the canonical circuit model completely represents the dc and small-signal characteristics of a PWM converter and is obtained after a considerable amount of matrix manipulations in order to single out the desirable input and output characteristics of the converter (input impedance, line-to-output transfer function, and output impedance) in addition to its control-to-output characteristics. The PWM switch model, on the other hand, represents only the dc and small-signal characteristics of the nonlinear part of the converter, which consists of the active and passive switches (the PWM switch), and is obtained after a few lines of very simple algebra. The dc and small-signal characteristics of a PWM converter are then obtained by replacing the PWM switch with its equivalent circuit model in a manner similar to obtaining the small-signal characteristics of linear amplifiers whereby the transistor is replaced by its equivalent circuit model. There are two advantages in using the model of the PWM switch. First, the PWM switch model allows many PWM converters to be analyzed using simple linear electronic circuit analysis programs (P-SPICE, MICRO-CAP to name a few), which allow for user-defined models (macros), without recourse to special-purpose programs which manipulate state-space equations. The second and more important advantage is a pedagogical one. More and more universities are beginning to teach power electronics at the senior level in their undergraduate program. Although students at this level are familiar with some matrix algebra, it would be far easier for them to learn all about the dc and small-signal properties of PWM converters using the method of equivalent circuit model which they learned in their electronics courses earlier. Students spend quite a bit of time learning about the nonlinear characteristics of the transistor and its small-signal equivalent circuit model. They later use this model to analyze the small-signal characteristics of linear amplifiers simply by replacing the transistor with its equivalent circuit model. Why not do the same in power electronics? Ultimately, whether or not the PWM switch model presented here is a useful

## Simplified Analysis of PWM Converters Using Model of PWM Switch Part II: Discontinuous Conduction Mode

VATCHÉ VORPÉRIAN  
Virginia Polytechnic Institute and State University

According to the method of state-space averaging, when a pulsewidth modulation (PWM) converter enters discontinuous conduction mode, the inductor current state is lost from the average model of the converter. In this work, it is shown that there is neither theoretical nor experimental justification of the disappearance of the inductor state as claimed by the method of state-space averaging. For example, when the model of the PWM switch in discontinuous conduction mode (DCM) is substituted

### INTRODUCTION

In this article the model of the pulsewidth modulation (PWM) switch in discontinuous conduction mode (DCM) is developed and used in the analysis of PWM converters operating in DCM. As in the case of continuous conduction mode (CCM) [3], the model of the PWM switch in DCM represents the dc and small-signal characteristics of the nonlinear part of the converter which consists of the active and passive switch pair as shown in Fig. 1. In contrast to the model in CCM, the model of the PWM switch in DCM contains small-signal resistances which damp the low-pass filter to the point where two real poles are formed. The physical significance of these small-signal resistances is easy to understand as they represent the load dependent nature of the conversion ratio of these converters in DCM. The motivation and advantages behind the method of analysis presented here are discussed in Part I of this paper [3].

Whereas, use of the model of the PWM switch in CCM yields the same results as those given by the method of state-space averaging, in DCM the model of the PWM switch yields results which are different than those given by state-space averaging [1]. The fundamental difference between the two methods is that state-space averaging predicts that the discontinuous current state does not contribute to the order of the average model while the PWM switch

# Modelo da chave PWM de Vorpérian

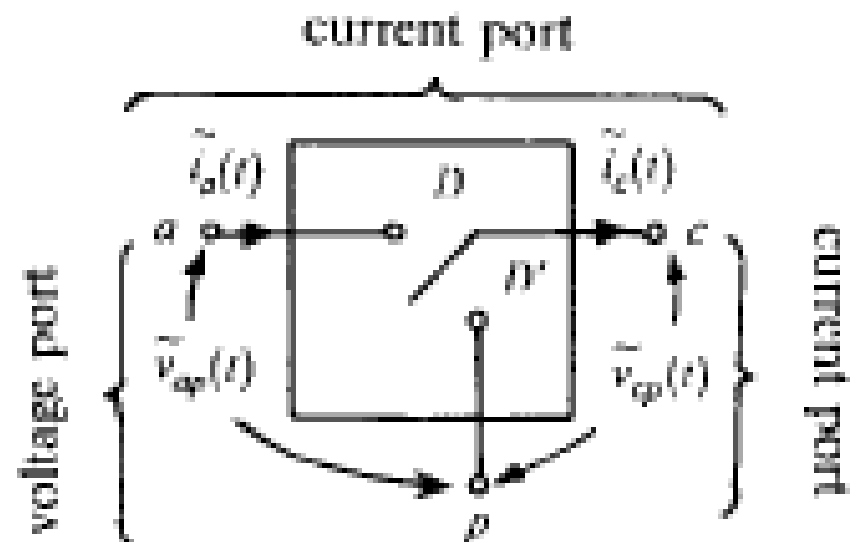
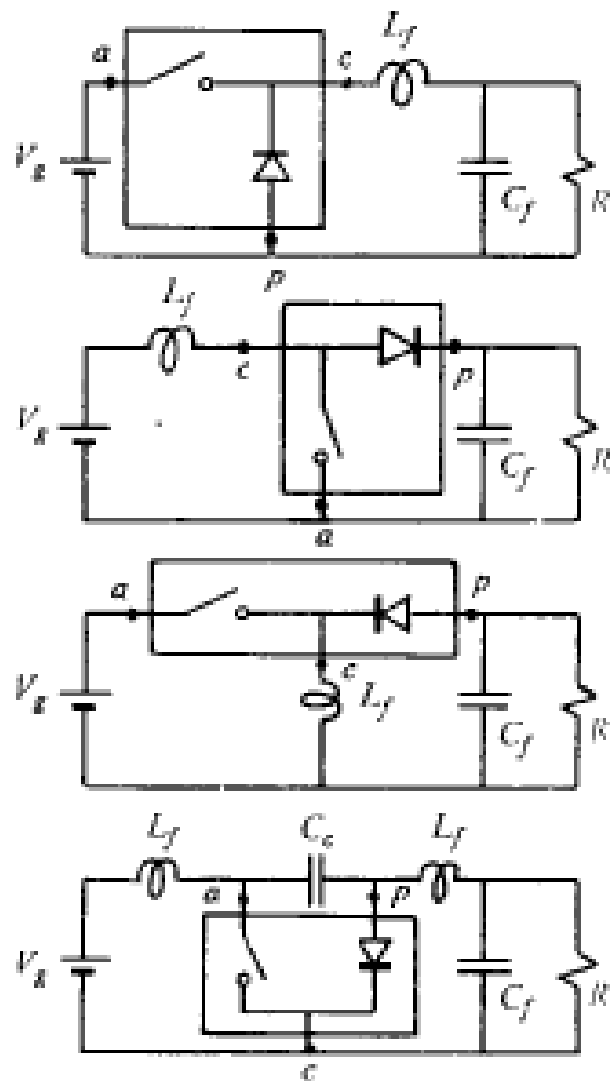

# Modelagem do sistema

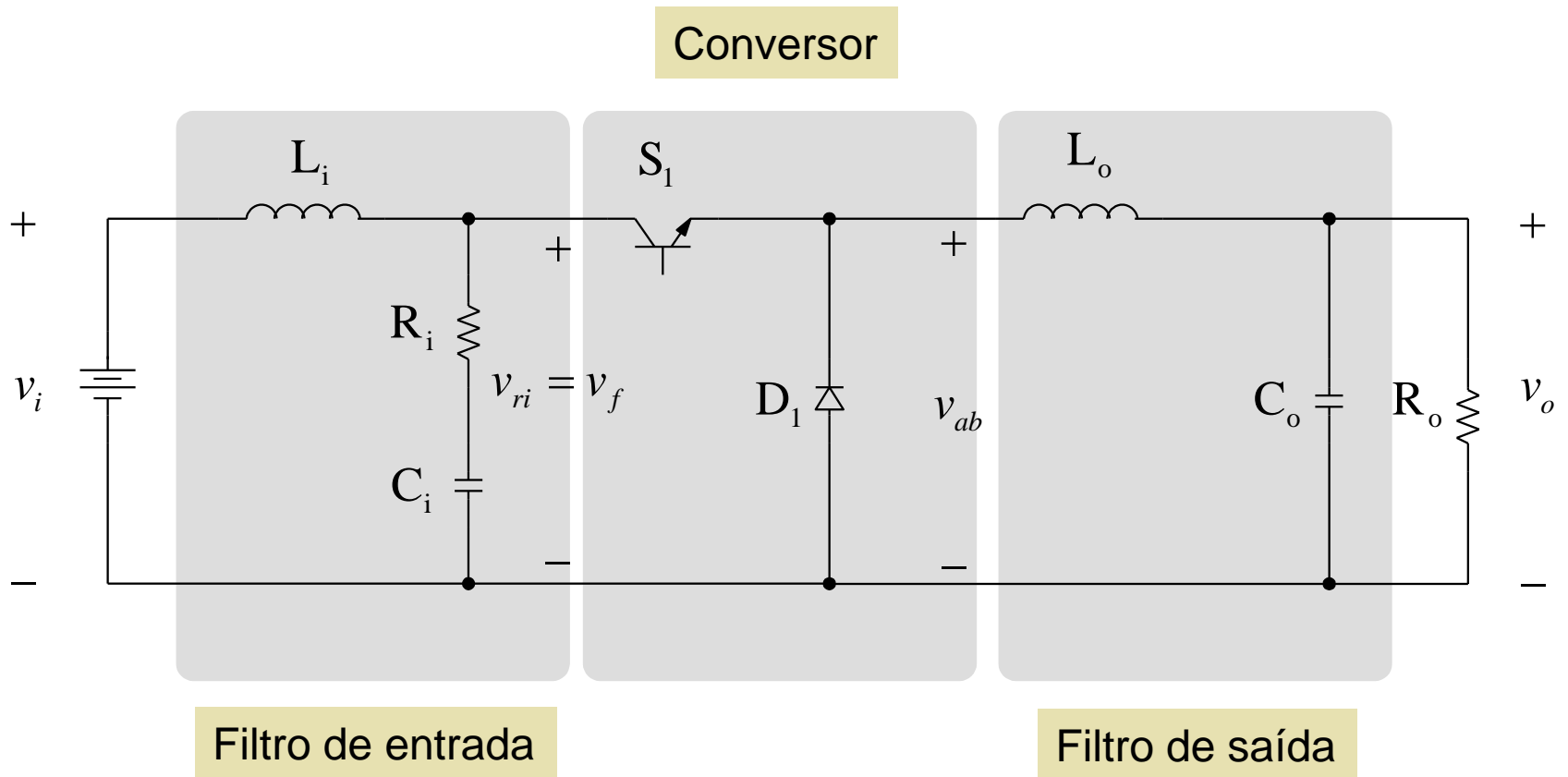

# Modelagem do conversor Buck

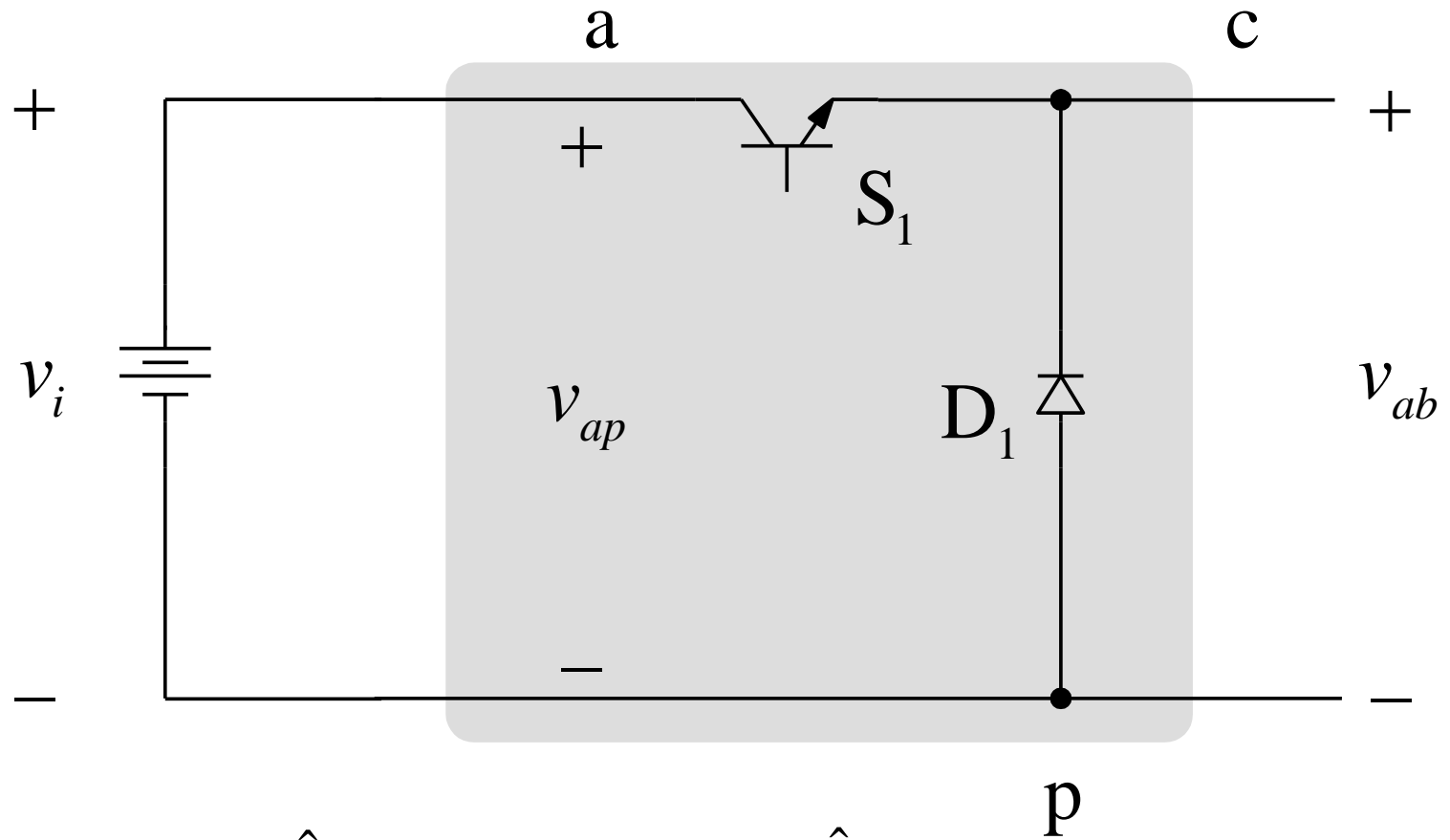

$$G_1(s) = \frac{\hat{v}_{ab}}{\hat{d}}$$

$$F_1(s) = \frac{\hat{v}_{ab}}{\hat{v}_i}$$

# Modelagem do conversor Buck

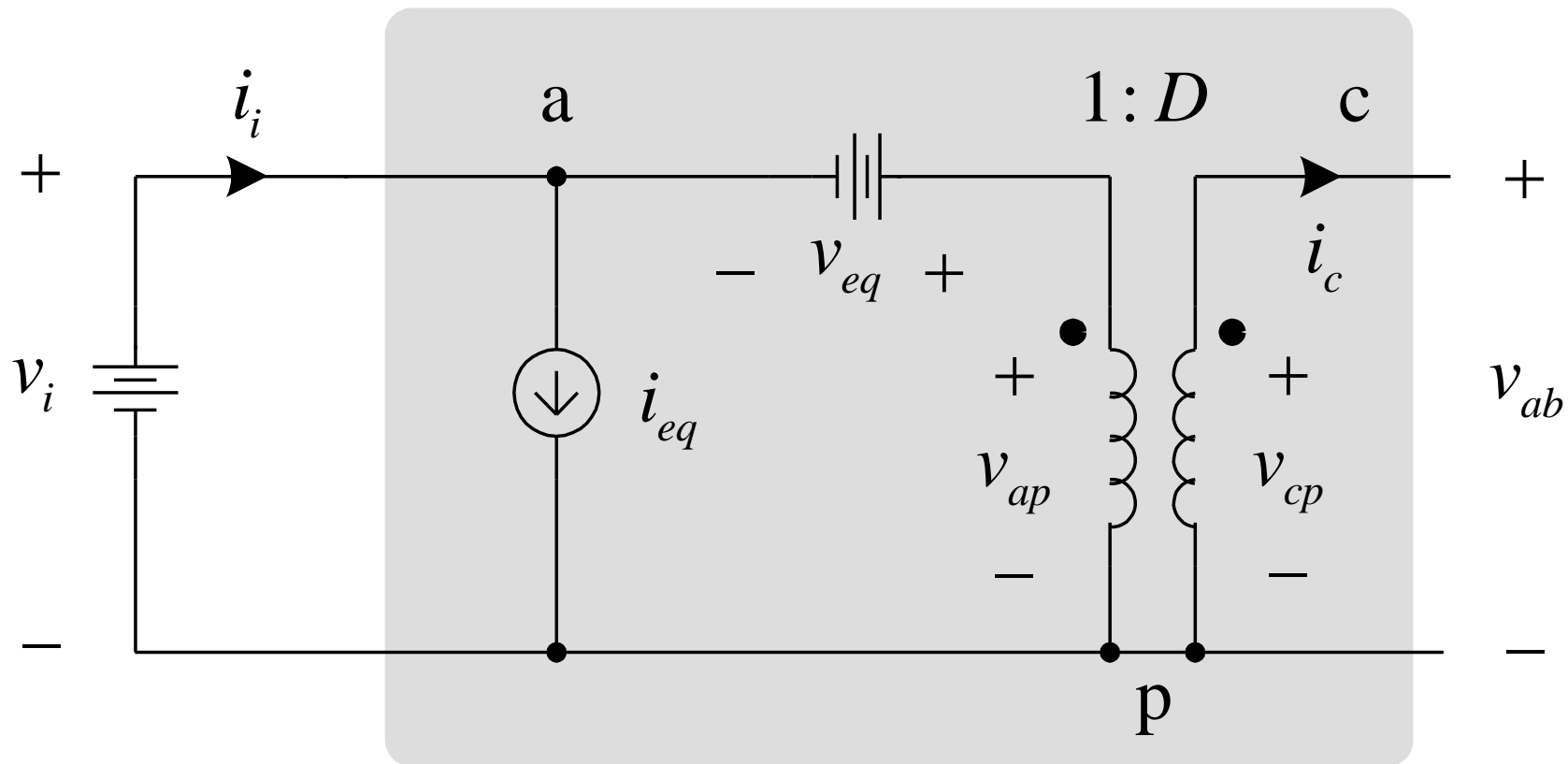

$$f = F + \hat{f}$$

$$i_{eq} = I_c \cdot \hat{d}$$

$$v_{eq} = \frac{V_{ap}}{D} \cdot \hat{d}$$

# Modelagem do conversor Buck

Modelo de regime permanente

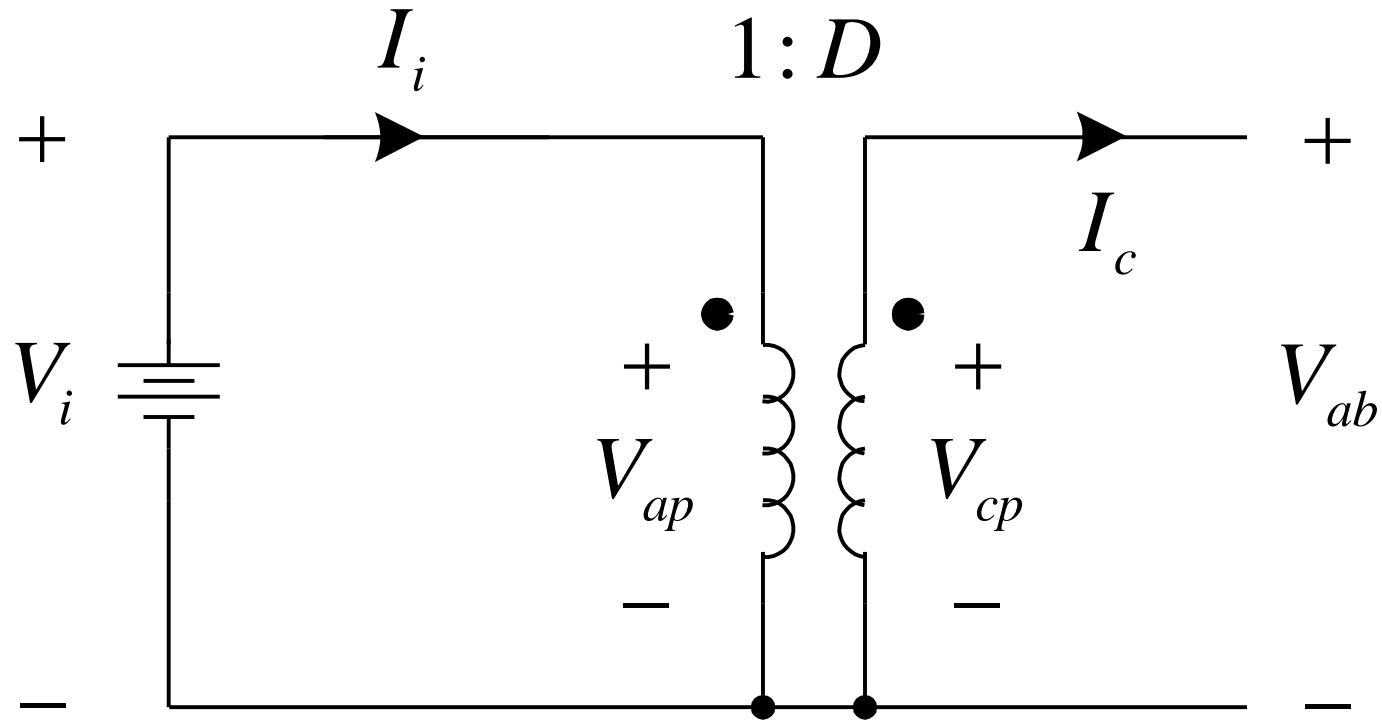

$$V_{ap} = V_i \quad V_{cp} = D \cdot V_{ap} = D \cdot V_i \quad V_{ab} = V_{cp} = D \cdot V_i \quad I_o = \frac{I_i}{D}$$

# Modelagem do conversor Buck

Modelo de pequenos sinais para determinar  $G(s)$ :

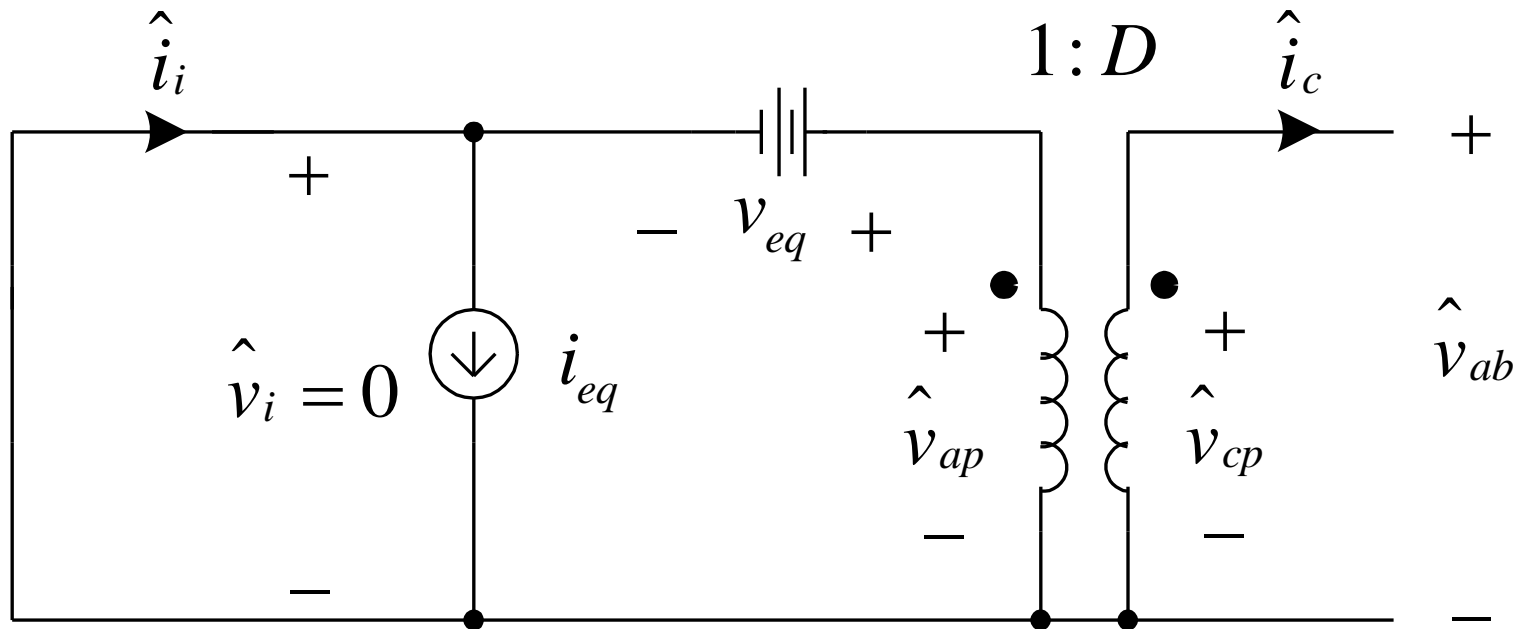

$$\hat{v}_{ap} = v_{eq} = \frac{V_{ap}}{D} \cdot \hat{d}$$

$$\hat{v}_{ap} = \frac{V_i}{D} \cdot \hat{d}$$

$$\hat{v}_{cp} = D \cdot \hat{v}_{ap} = D \cdot \frac{V_i}{D} \cdot \hat{d} = V_i \cdot \hat{d}$$

$$\hat{v}_{ab} = \hat{v}_{cp} = V_i \cdot \hat{d}$$

$$V_{ap} = V_i$$

# Modelagem do conversor Buck

Modelo de pequenos sinais para determinar  $G(s)$ :

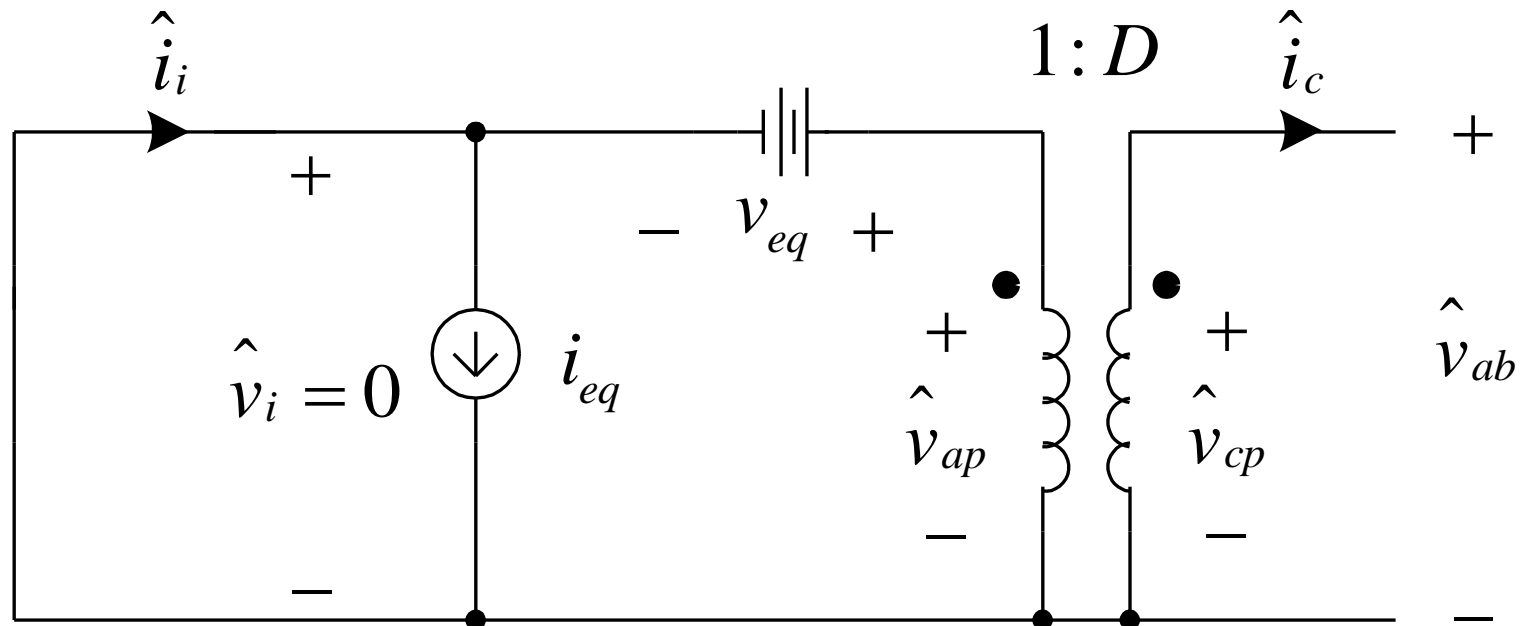

$$\hat{v}_{ab} = \hat{v}_{cp} = V_i \cdot \hat{d}$$

$$G_1(s) = \frac{\hat{v}_{ab}}{\hat{d}} = V_i$$

Note que  $i_i$  não interfere em  $G(s)$ .

# Modelagem do conversor Buck

Modelo de pequenos sinais para determinar  $F(s)$ :

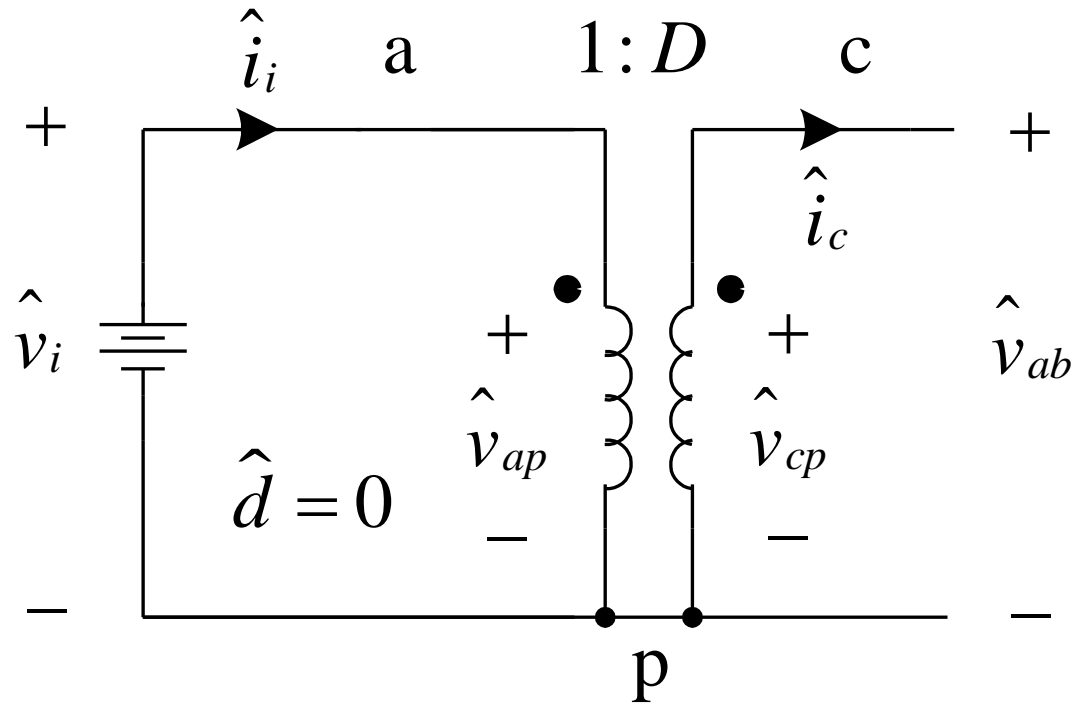

$$\hat{v}_{cp} = D \cdot \hat{v}_{ap} = D \cdot \hat{v}_i$$

$$\hat{v}_{ab} = \hat{v}_{cp} = D \cdot \hat{v}_i$$

$$F_1(s) = \frac{\hat{v}_{ab}}{\hat{v}_i} = D$$

Note que  $i_i$  não interfere em  $F(s)$ .

# Modelagem do filtro de saída

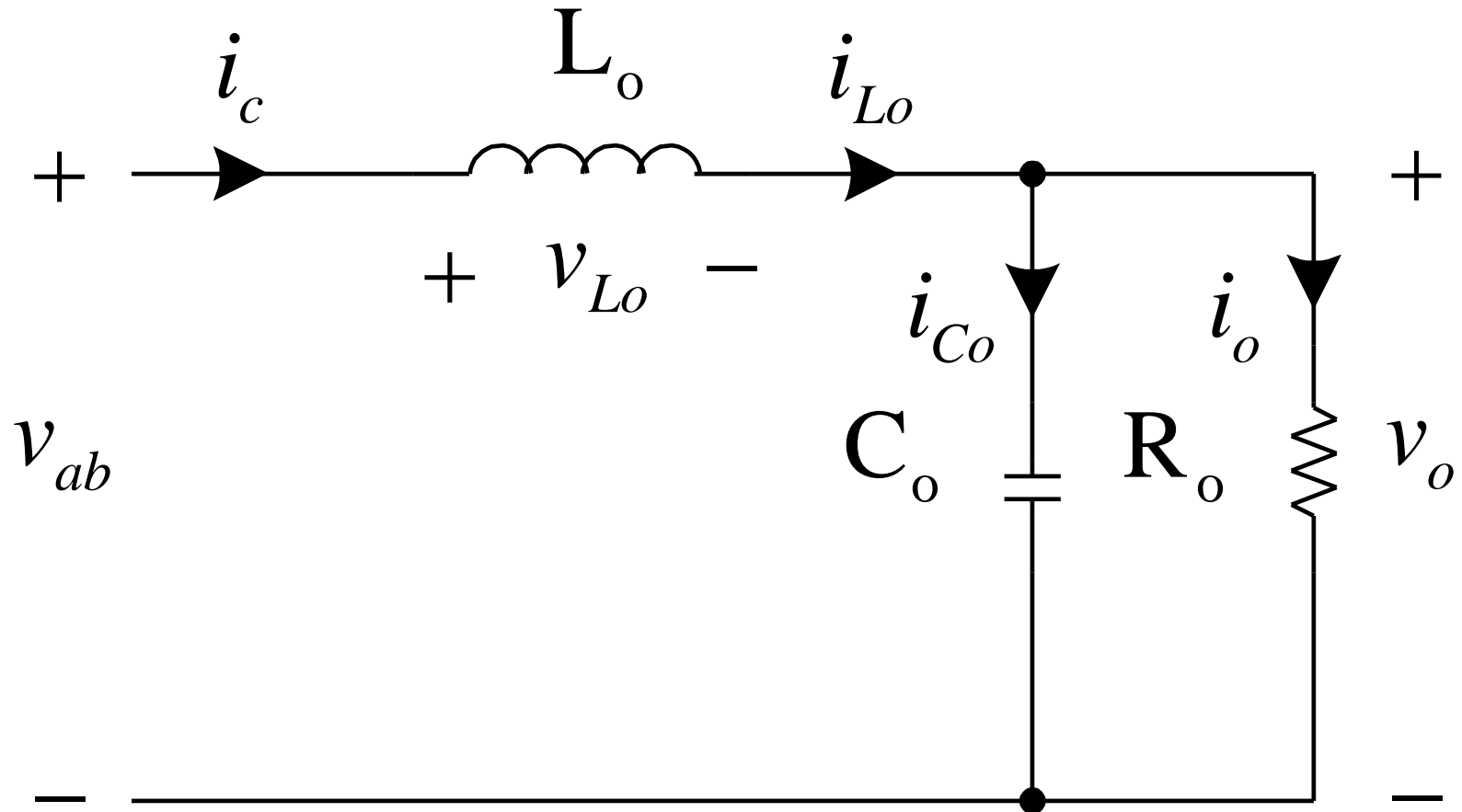

# Modelagem do filtro de saída

Modelo de regime permanente

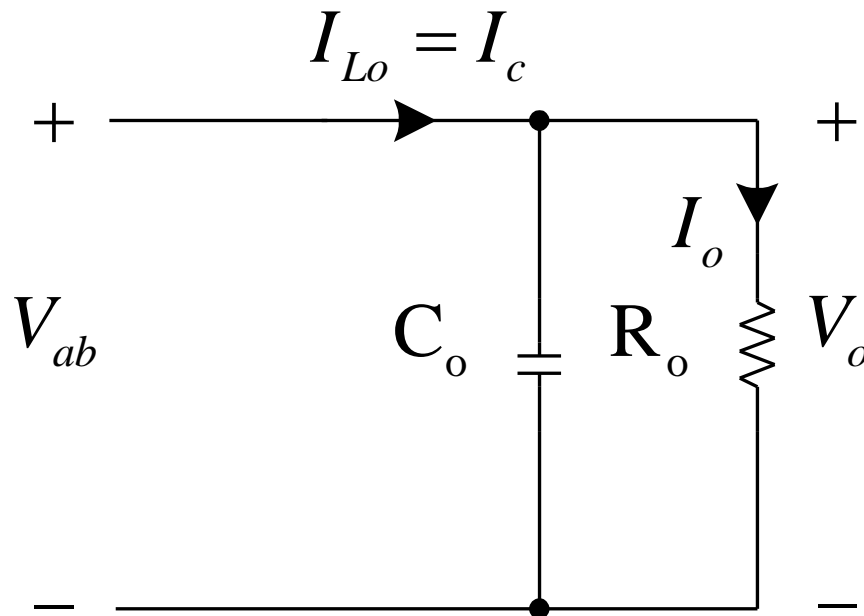

$$V_o = V_{ab}$$

$$I_o = \frac{V_o}{R_o}$$

$$I_{Lo} = I_o = I_c = \frac{V_o}{R_o}$$

# Modelagem do filtro de saída

Modelo de pequenos sinais para determinar  $G(s)$ :

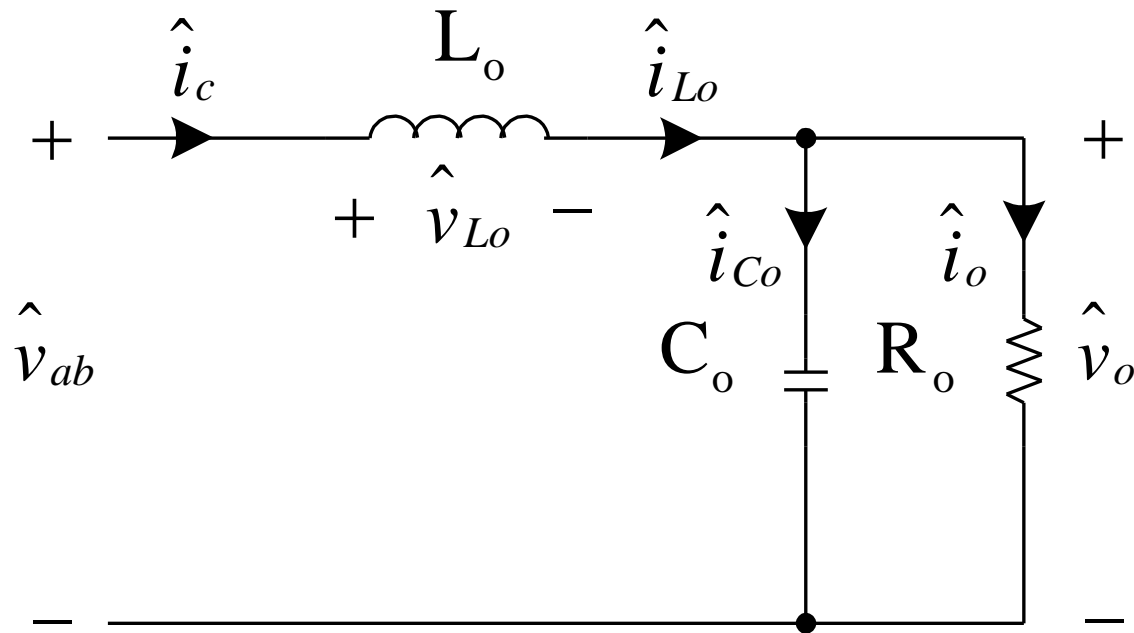

$$\hat{v}_{ab} = \hat{v}_{Lo} + \hat{v}_o$$

$$\hat{v}_{Lo} = s \cdot L_o \cdot \hat{i}_{Lo}$$

$$\hat{i}_o = \frac{\hat{v}_o}{R_o}$$

$$\hat{v}_{ab} = s \cdot L_o \cdot \hat{i}_{Lo} + \frac{\hat{v}_o}{R_o}$$

# Modelagem do filtro de saída

Modelo de pequenos sinais para determinar  $G(s)$ :

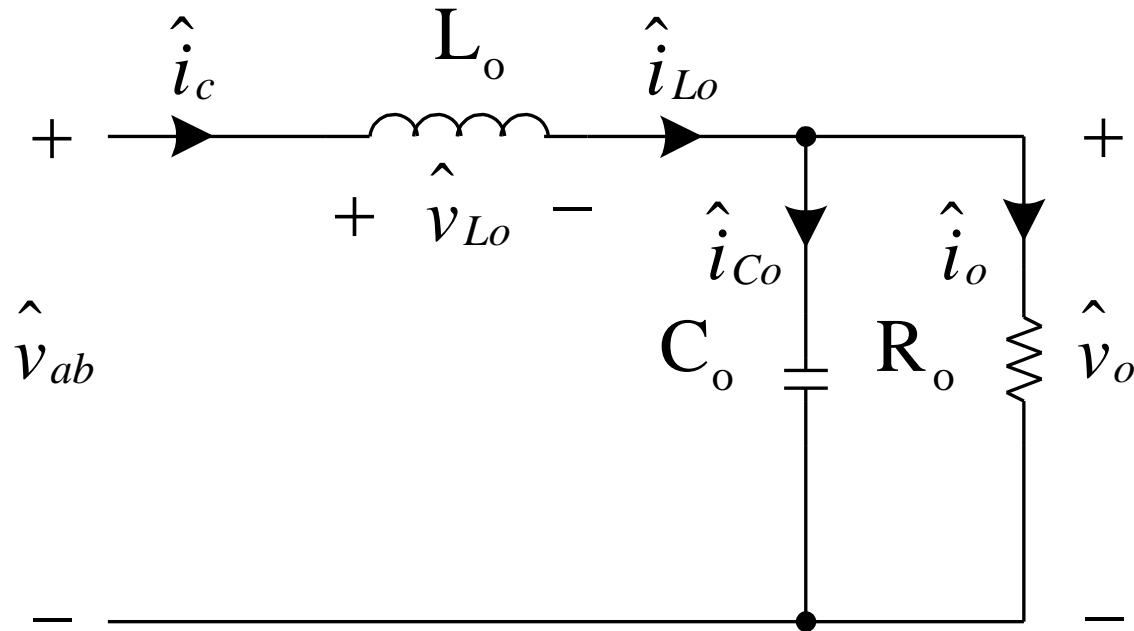

$$\hat{i}_{L_o} = \hat{i}_{C_o} + \hat{i}_o$$
$$\hat{i}_{L_o} = s \cdot C_o \cdot \hat{v}_o + \frac{\hat{v}_o}{R_o}$$
$$\hat{i}_{C_o} = s \cdot C_o \cdot \hat{v}_o$$
$$\hat{v}_{ab} = s \cdot L_o \cdot \left( s \cdot C_o \cdot \hat{v}_o + \frac{\hat{v}_o}{R_o} \right) + \hat{v}_o$$

# Modelagem do filtro de saída

Modelo de pequenos sinais para determinar  $G(s)$ :

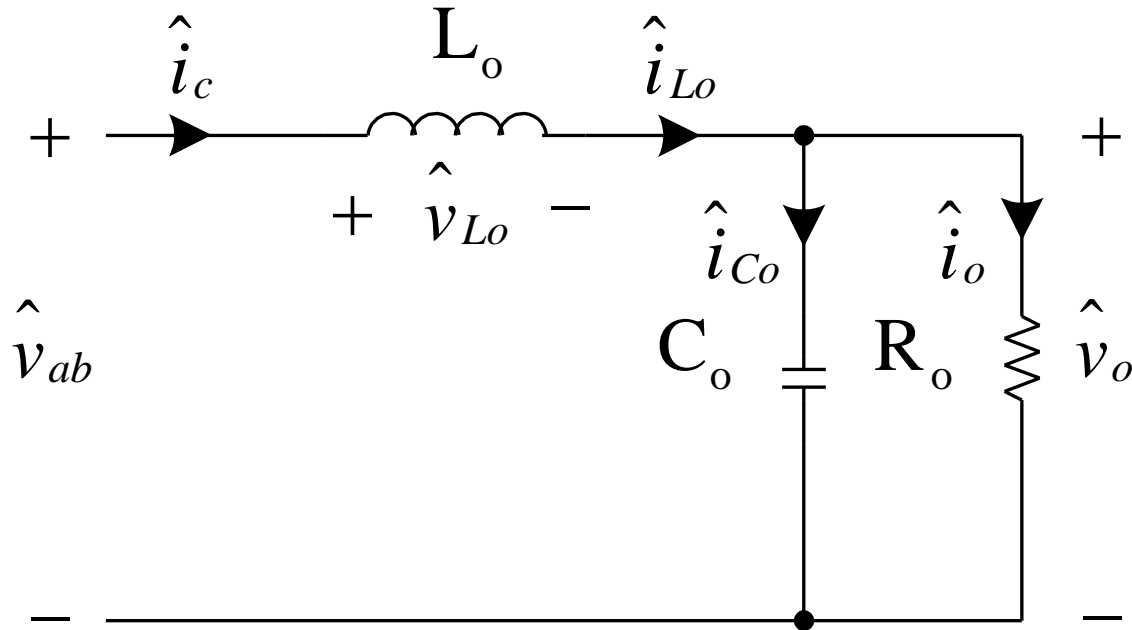

$$G_2(s) = \frac{\hat{v}_o}{\hat{v}_{ab}} = \frac{R_o}{s^2 \cdot L_o \cdot C_o \cdot R_o + s \cdot L_o + R_o}$$

# Modelagem do filtro de saída

Modelo de pequenos sinais para determinar  $F(s)$ :

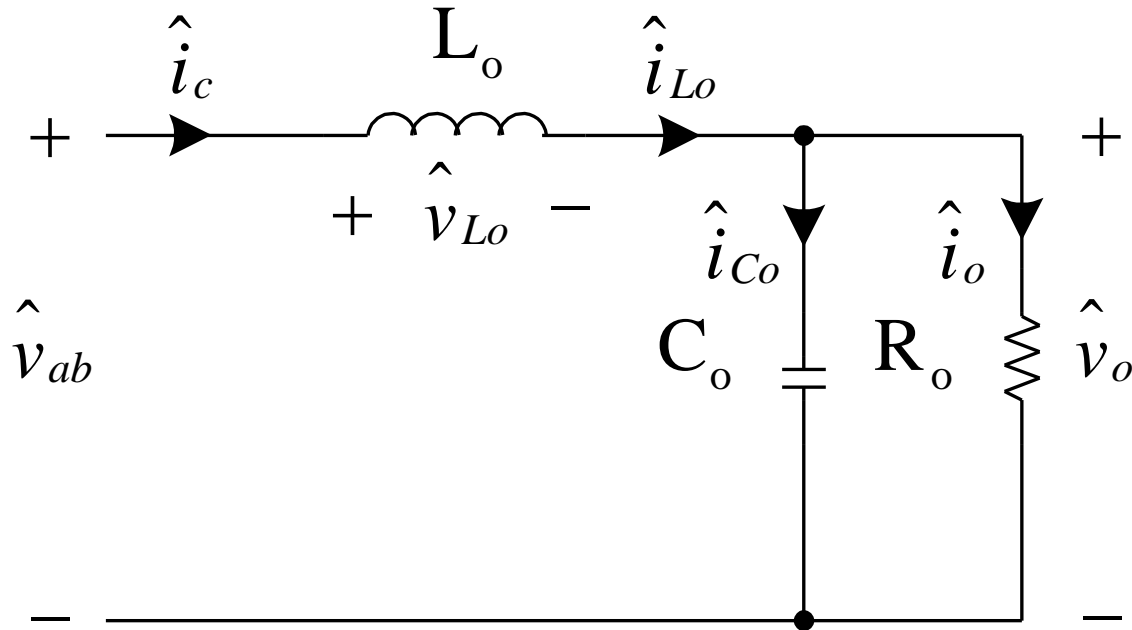

$$F_2(s) = \frac{\hat{v}_o}{\hat{v}_{ab}} = \frac{R_o}{s^2 \cdot L_o \cdot C_o \cdot R_o + s \cdot L_o + R_o}$$

# Modelo completo do conversor

Função de transferência da tensão de saída pela razão cíclica  $G(s)$ :

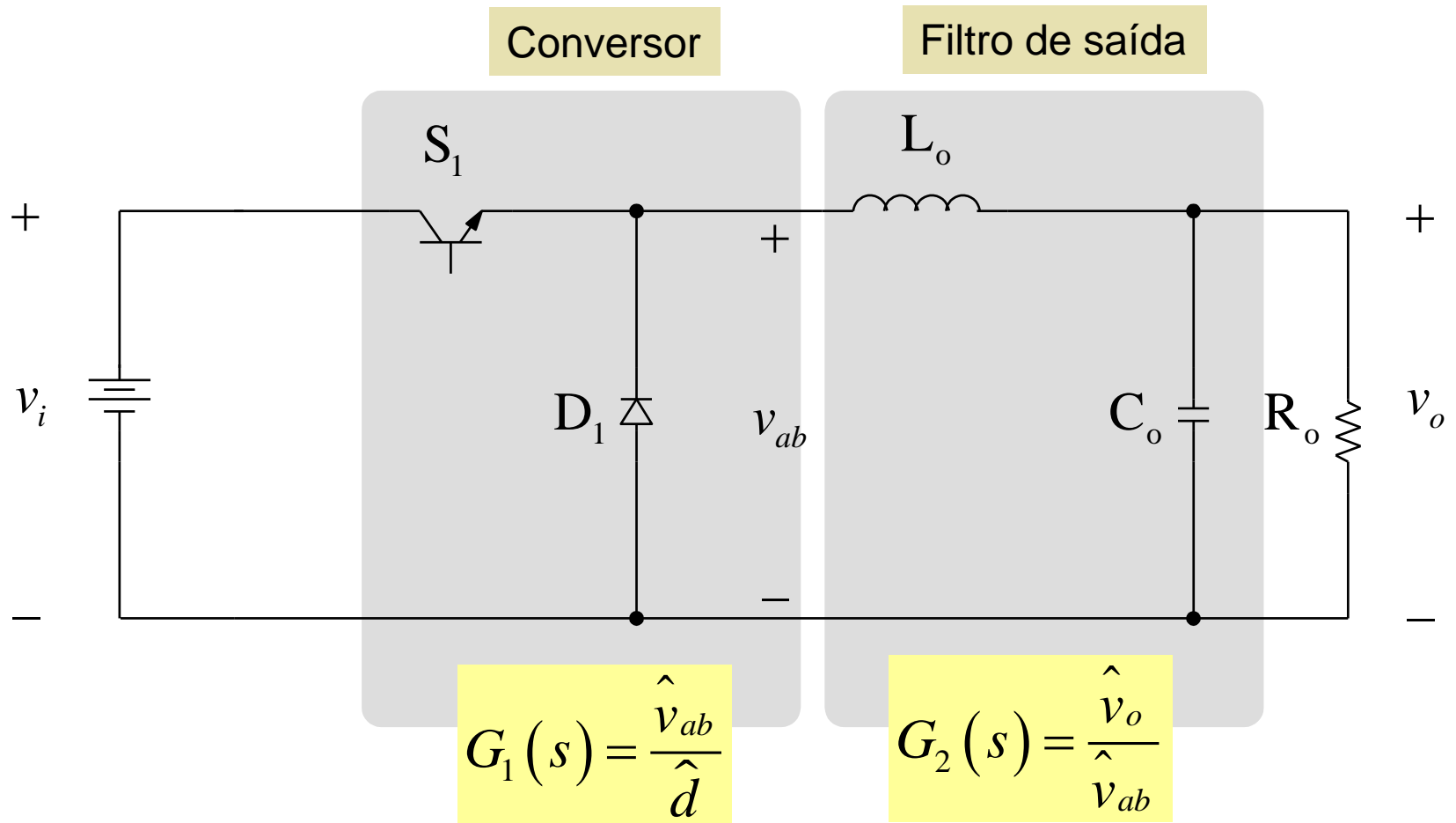

# Modelo completo do conversor

Função de transferência da tensão de saída pela razão cíclica  $G(s)$ :

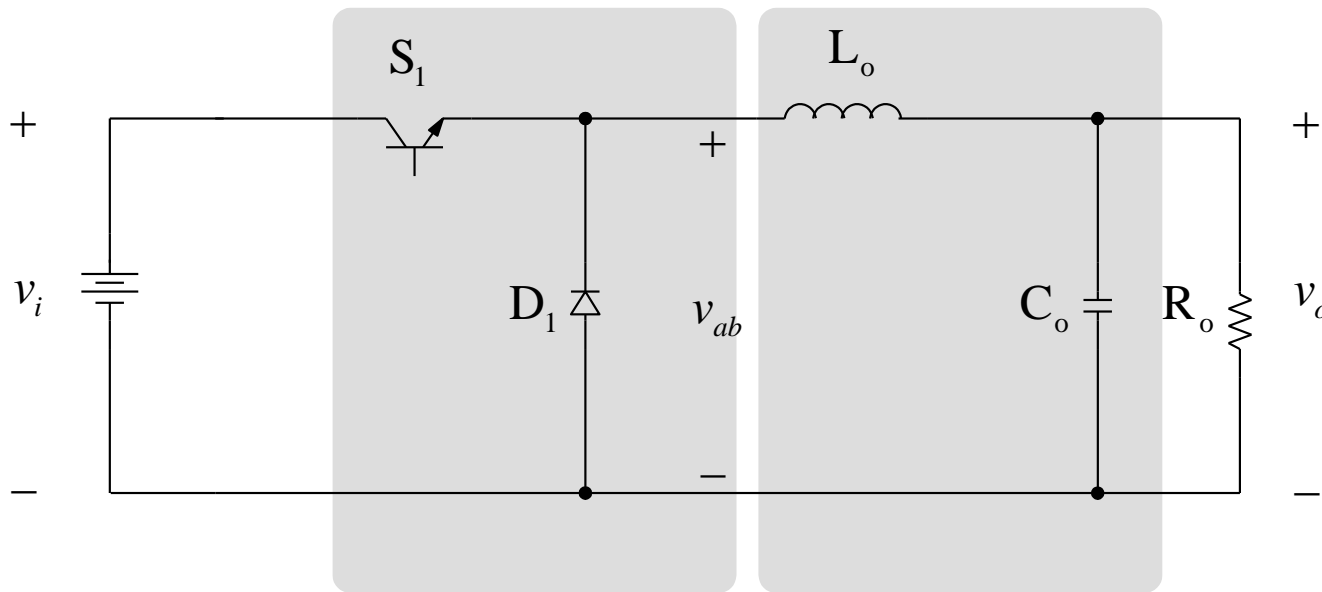

$$G(s) = G_1(s) \cdot G_2(s) = \frac{\hat{v}_{ab}}{\hat{d}} \cdot \frac{\hat{v}_o}{\hat{v}_{ab}} = \frac{\hat{v}_o}{\hat{d}} = V_i \cdot \frac{R_o}{s^2 \cdot L_o \cdot C_o \cdot R_o + s \cdot L_o + R_o}$$

# Modelo completo do conversor

Função de transferência da tensão de saída pela razão cíclica  $G(s)$ :

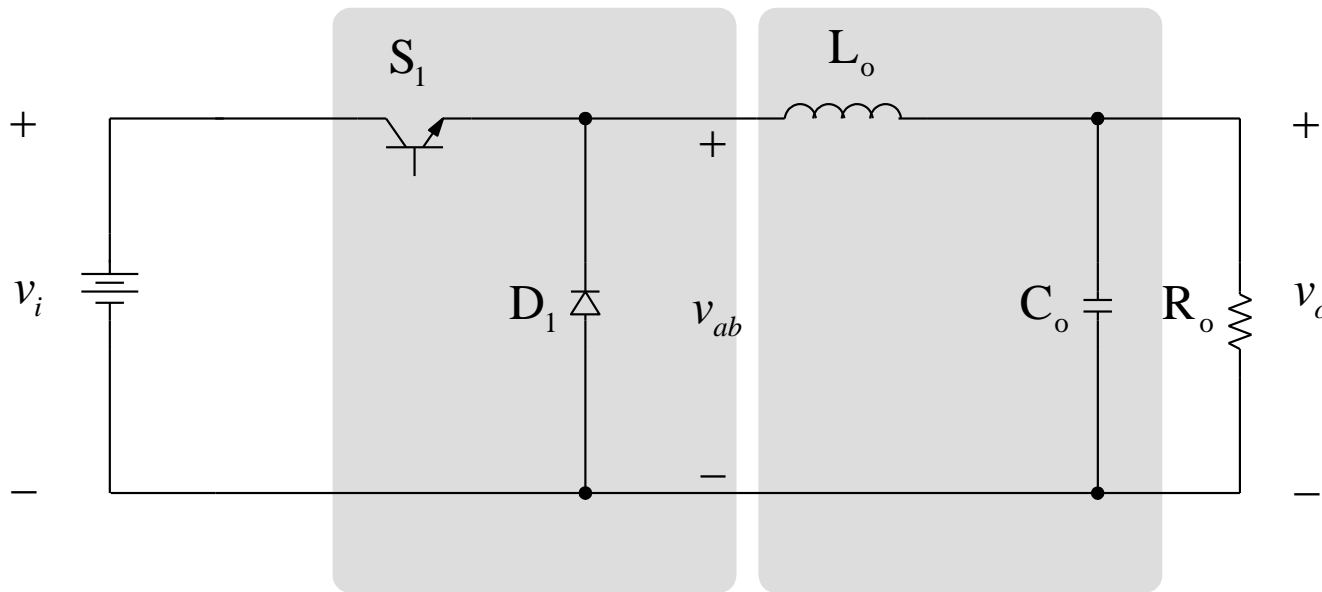

$$G(s) = \frac{V_i \cdot R_o}{s^2 \cdot L_o \cdot C_o \cdot R_o + s \cdot L_o + R_o}$$

# Modelo completo do conversor

Função de transferência da tensão de saída pela razão cíclica  $G(s)$ :

$$G(s) = \frac{V_i \cdot R_o}{s^2 \cdot L_o \cdot C_o \cdot R_o + s \cdot L_o + R_o}$$



Diagrama de bode de módulo e fase.

# Modelo completo do conversor

Função de transferência da tensão de saída pela razão cíclica  $G(s)$ :

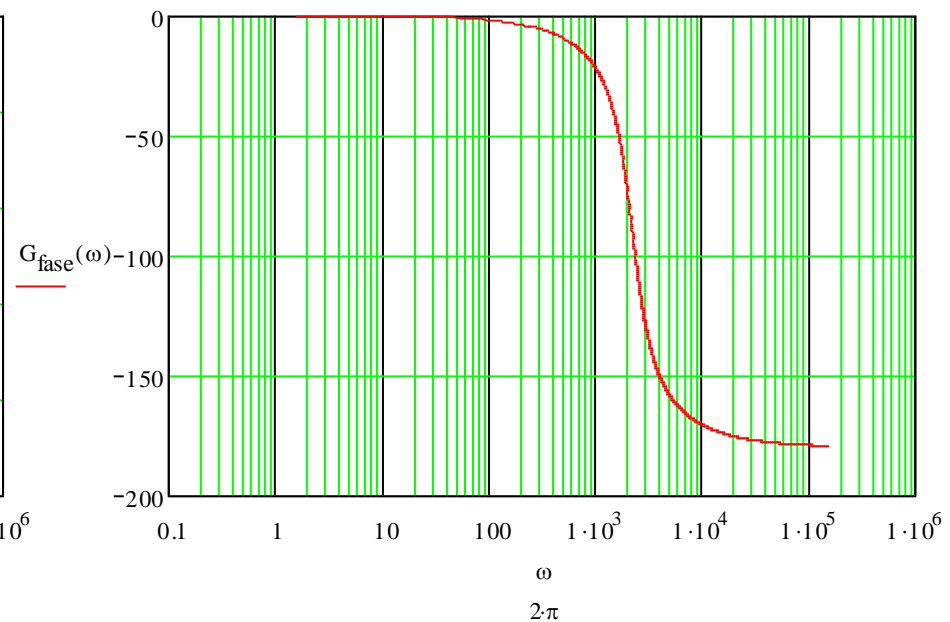
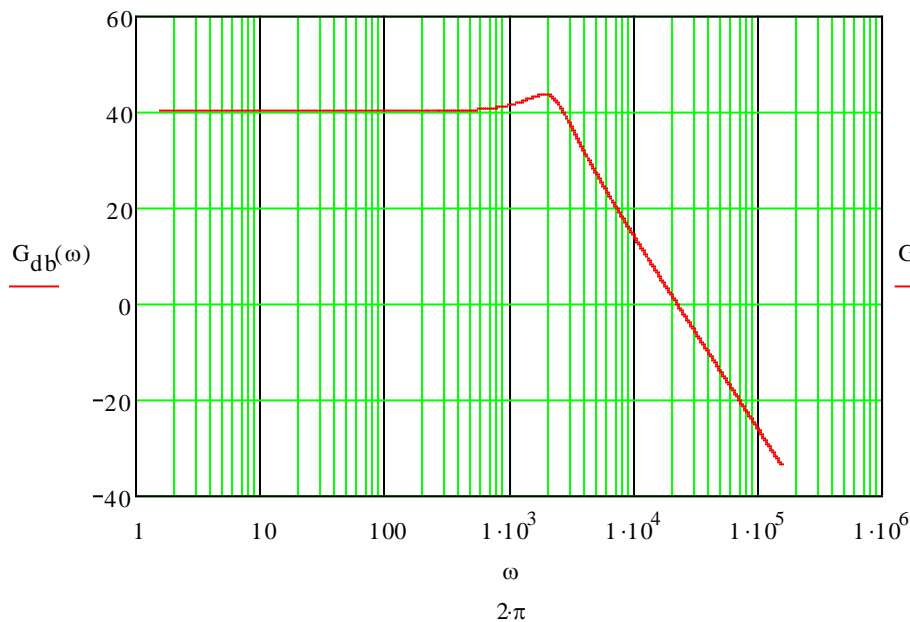
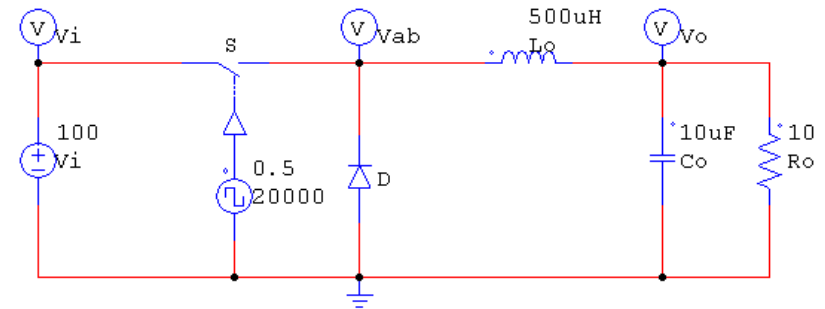
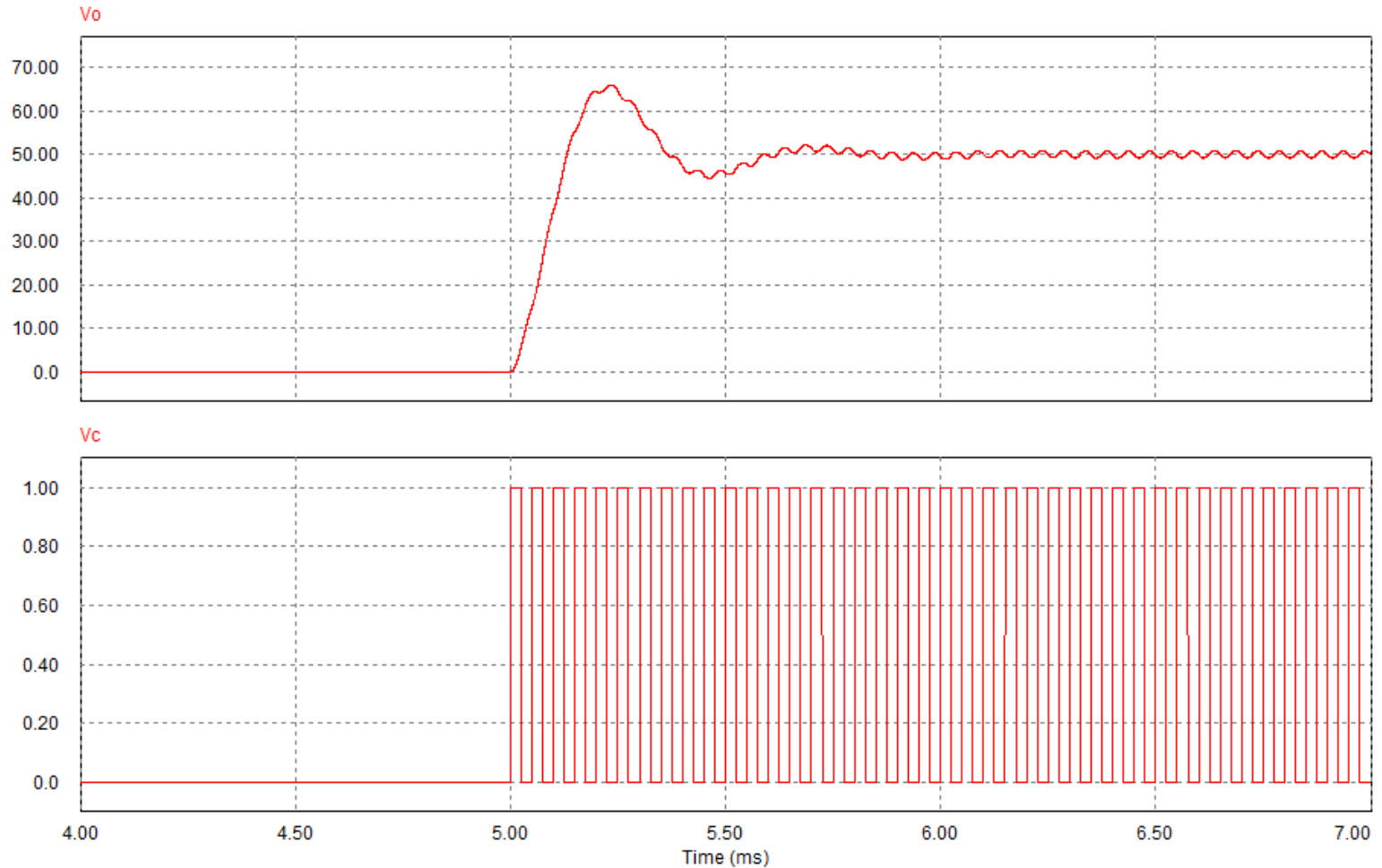

# Modelo completo do conversor

Função de transferência da tensão de saída pela tensão de entrada  $F(s)$ :

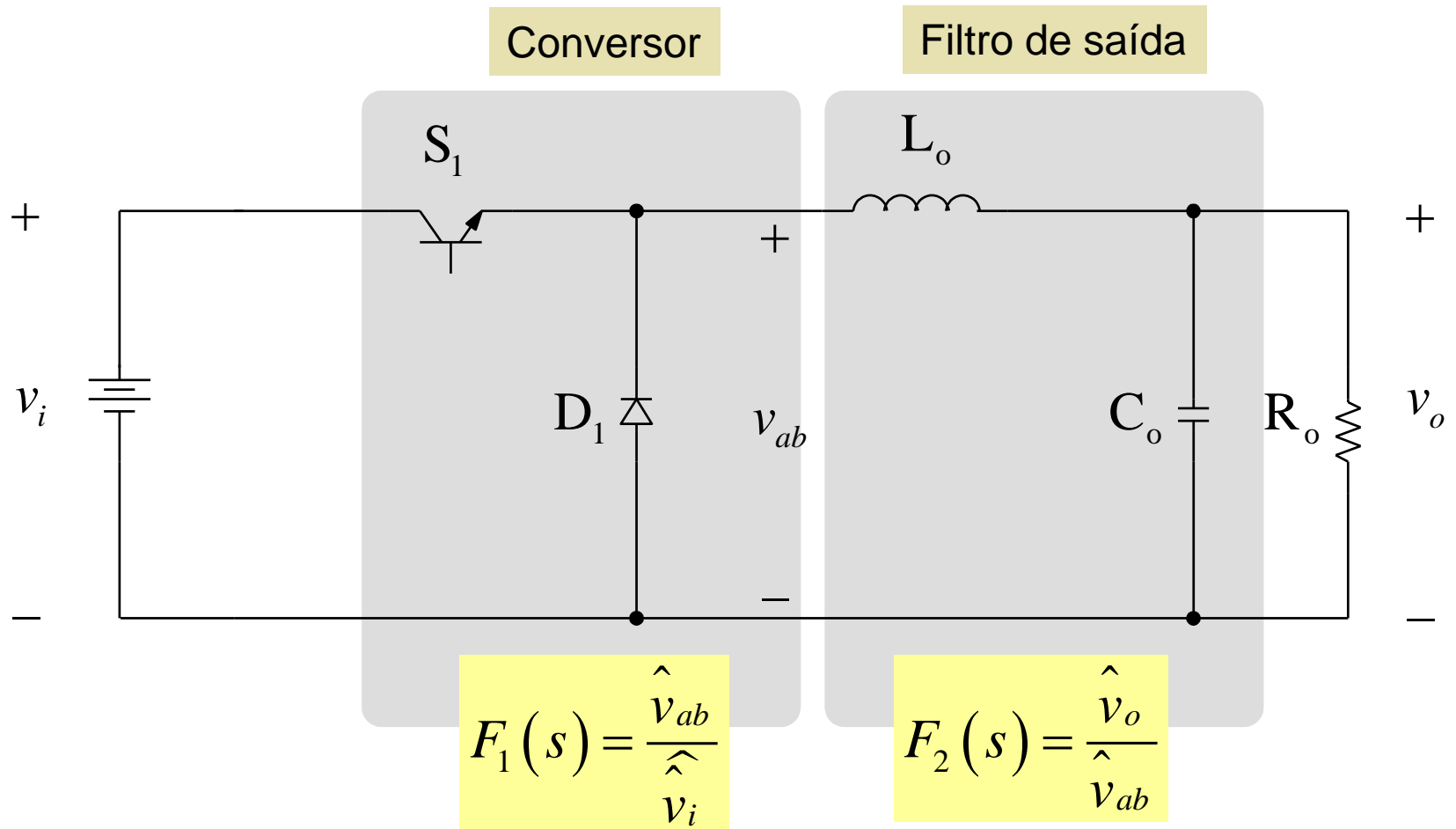

# Modelo completo do conversor

Função de transferência da tensão de saída pela tensão de entrada  $F(s)$ :

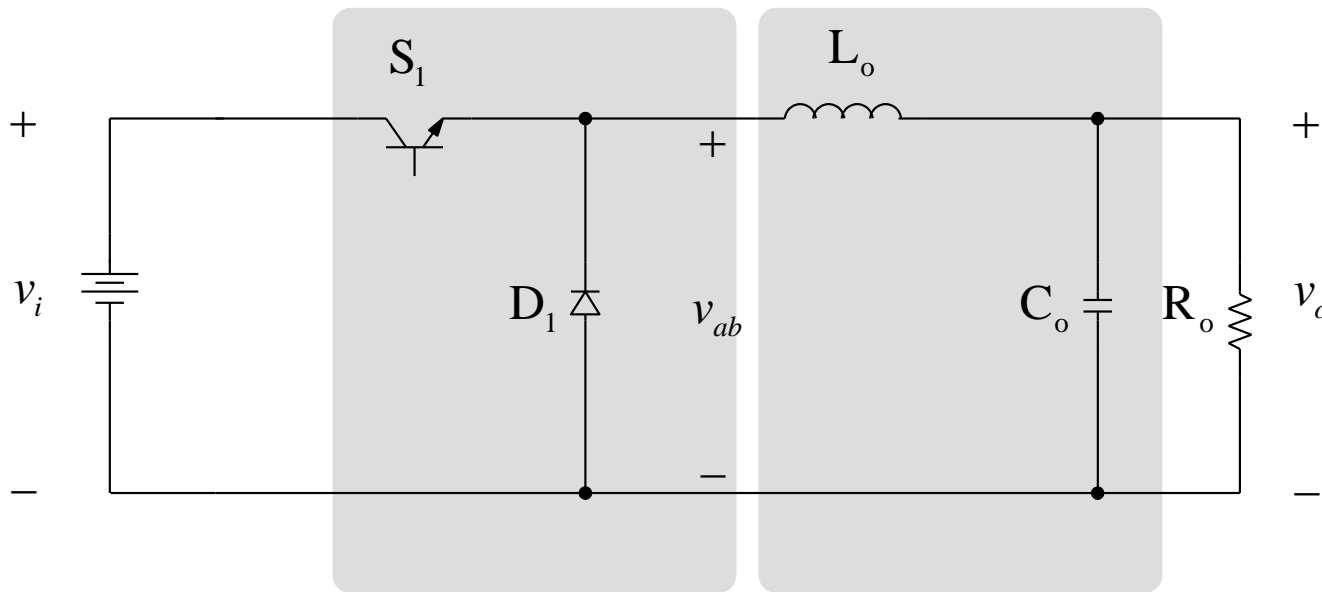

$$F(s) = F_1(s) \cdot F_2(s) = \frac{\hat{v}_{ab}}{\hat{v}_i} \cdot \frac{\hat{v}_o}{\hat{v}_{ab}} = \frac{\hat{v}_o}{\hat{v}_i} = D \cdot \frac{R_o}{s^2 \cdot L_o \cdot C_o \cdot R_o + s \cdot L_o + R_o}$$

# Modelo completo do conversor

Função de transferência da tensão de saída pela tensão de entrada  $F(s)$ :

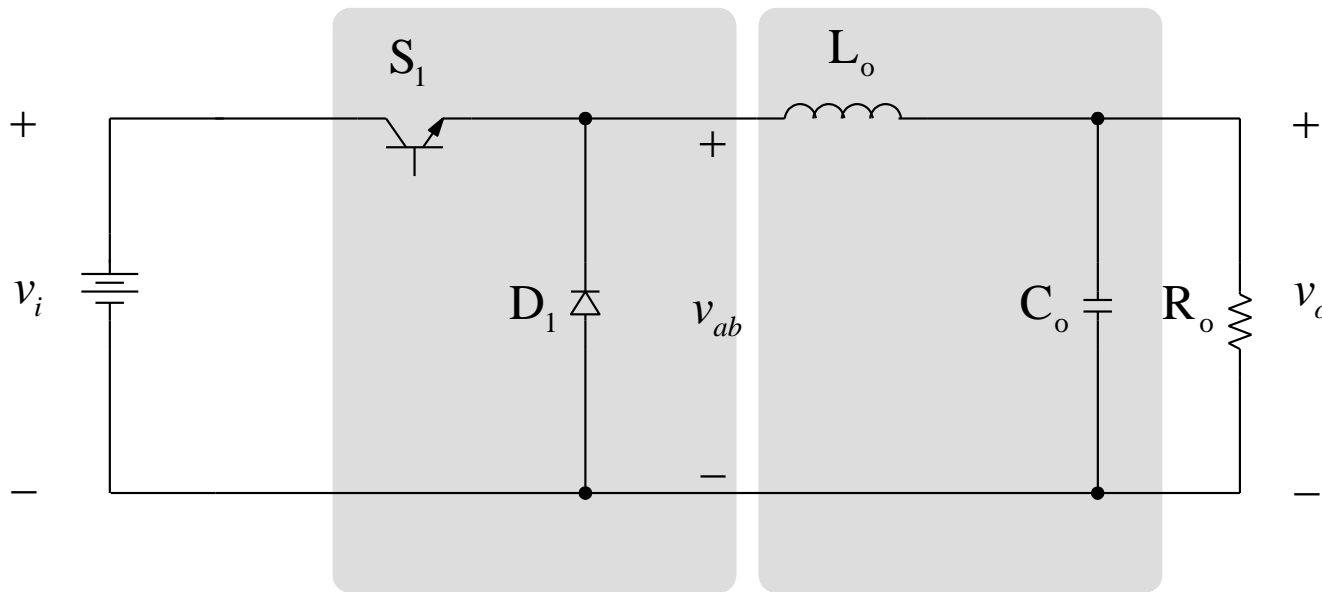

$$F(s) = \frac{D \cdot R_o}{s^2 \cdot L_o \cdot C_o \cdot R_o + s \cdot L_o + R_o}$$

# Modelo completo do conversor

Função de transferência da tensão de saída pela tensão de entrada  $F(s)$ :

$$F(s) = \frac{D \cdot R_o}{s^2 \cdot L_o \cdot C_o \cdot R_o + s \cdot L_o + R_o}$$



Diagrama de bode de módulo e fase.

# Modelo completo do conversor

Função de transferência da tensão de saída pela tensão de entrada  $F(s)$ :

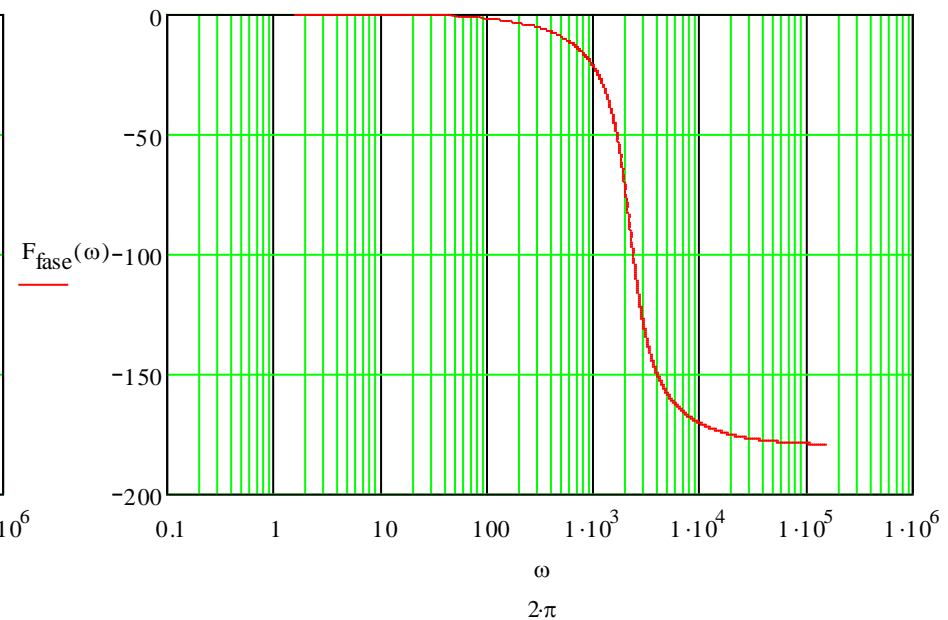
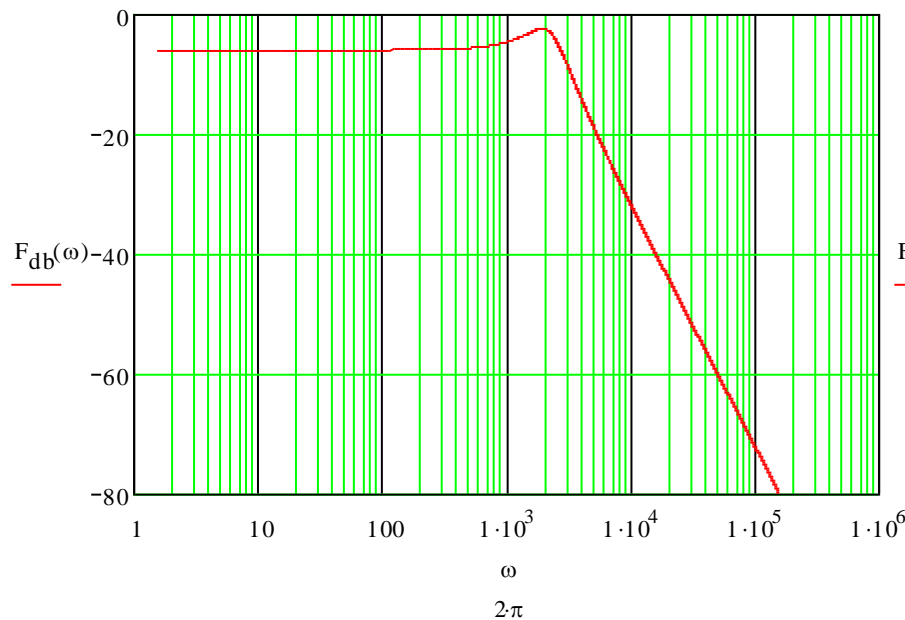
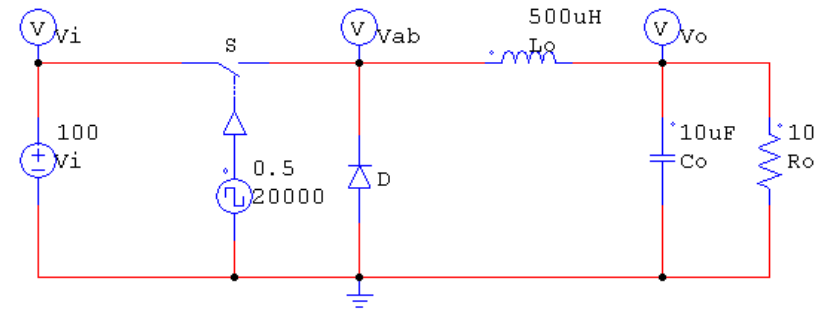
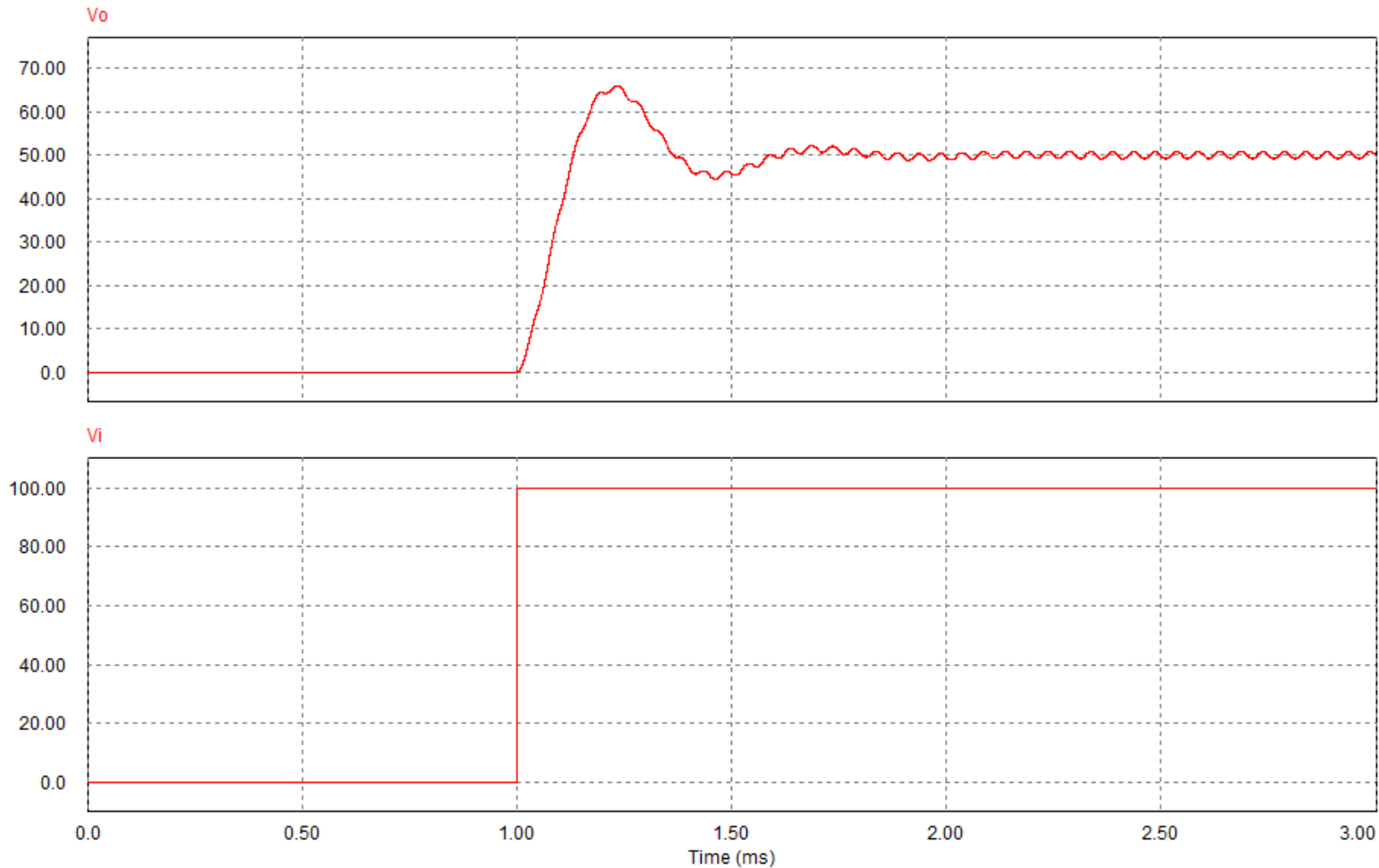

# Verificação das funções de transferência

Função de transferência da tensão de saída pela razão cíclica  $G(s)$ :

$$G(s) = \frac{V_i \cdot R_o}{s^2 \cdot L_o \cdot C_o \cdot R_o + s \cdot L_o + R_o} = \frac{1000}{s^2 \cdot 50 \cdot 10^{-9} + s \cdot 500 \cdot 10^{-6} + 10}$$

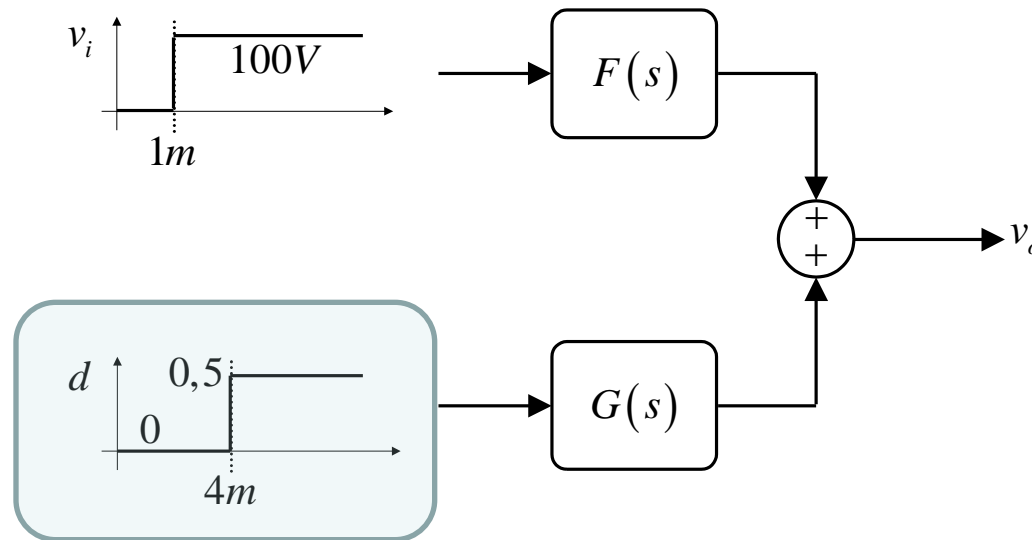

# Verificação das funções de transferência

Função de transferência da tensão de saída pela razão cíclica  $G(s)$ :

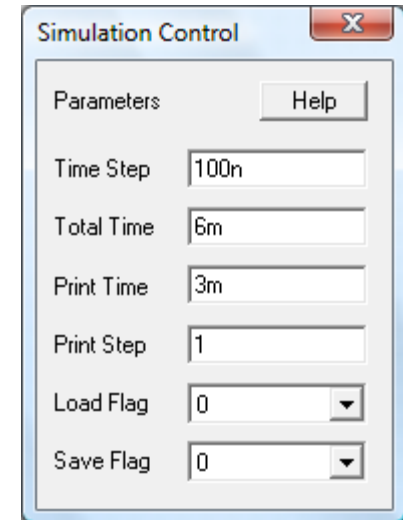
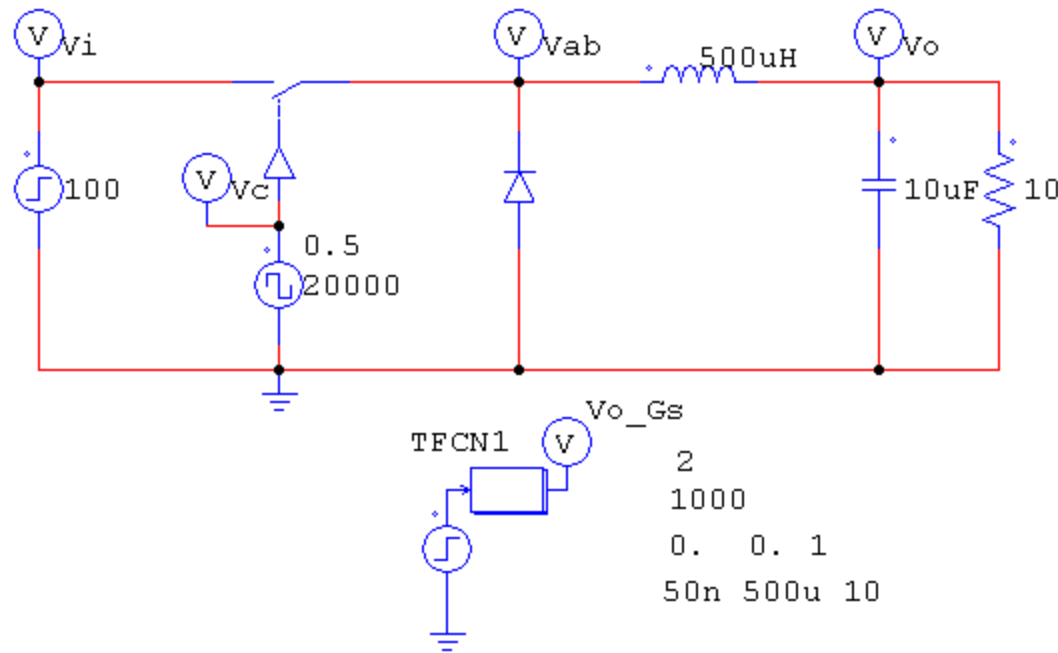

# Verificação das funções de transferência

Função de transferência da tensão de saída pela razão cíclica  $G(s)$ :

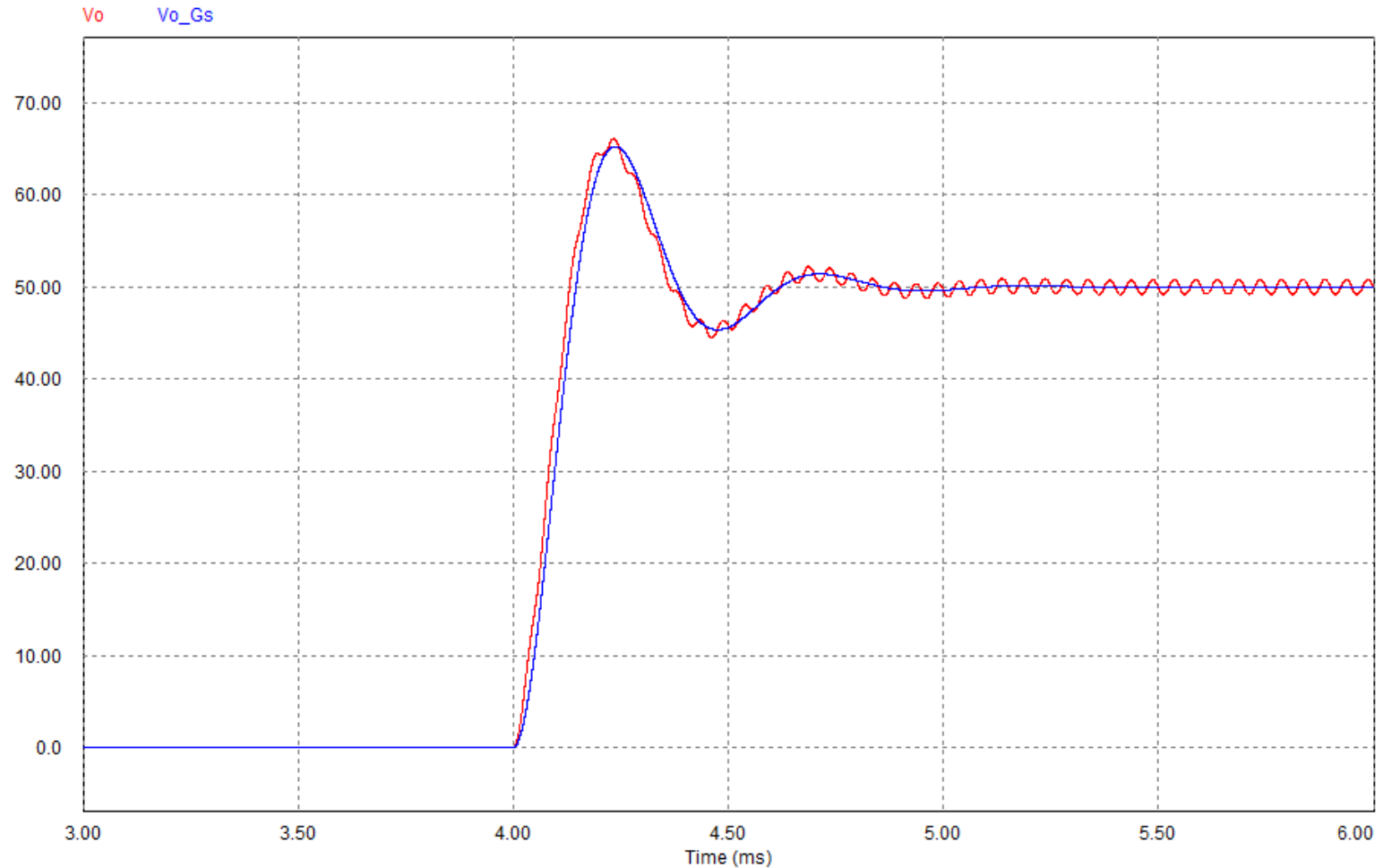

# Verificação das funções de transferência

Função de transferência da tensão de saída pela tensão de entrada  $F(s)$ :

$$F(s) = \frac{D \cdot R_o}{s^2 \cdot L_o \cdot C_o \cdot R_o + s \cdot L_o + R_o} = \frac{5}{s^2 \cdot 50 \cdot 10^{-9} + s \cdot 500 \cdot 10^{-6} + 10}$$

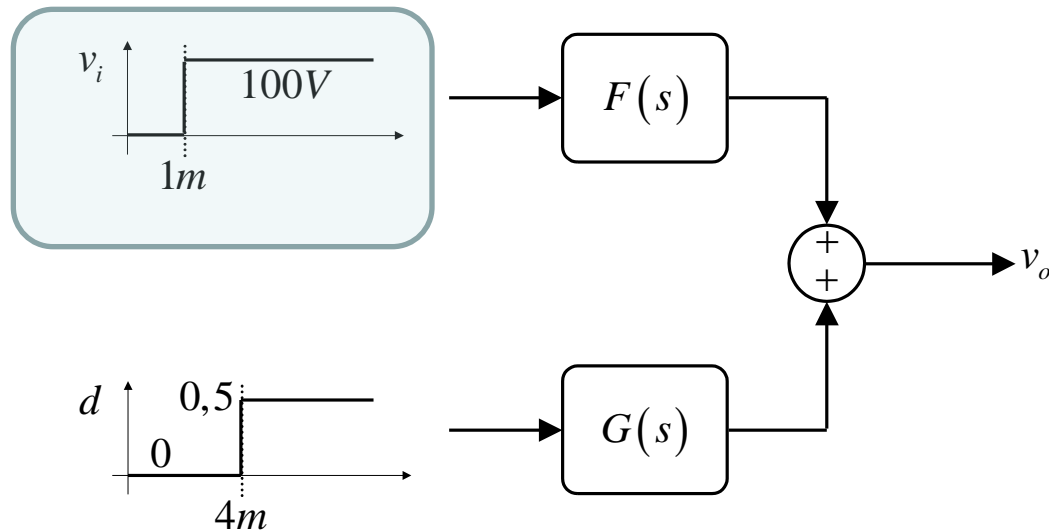

# Verificação das funções de transferência

Função de transferência da tensão de saída pela tensão de entrada  $F(s)$ :

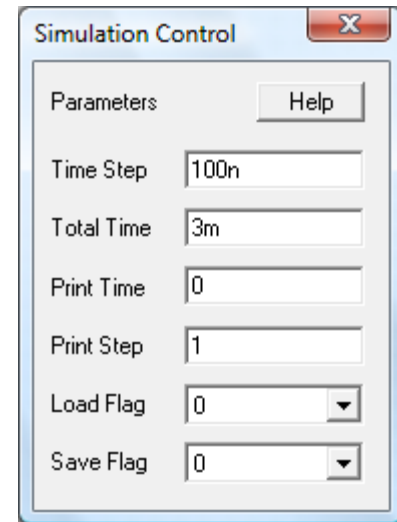
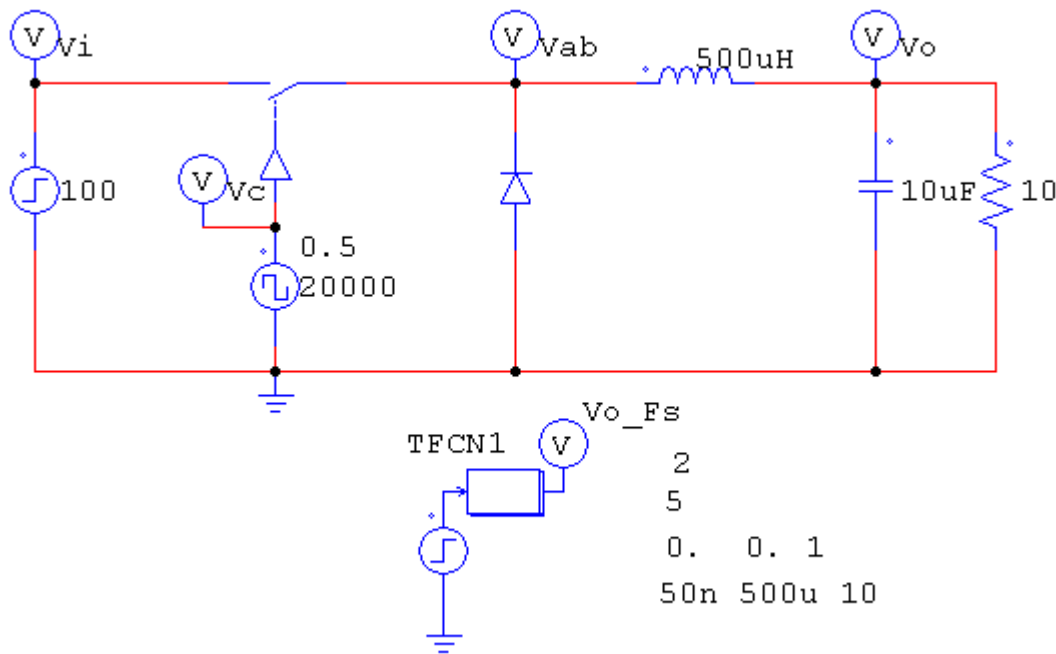

# Verificação das funções de transferência

Função de transferência da tensão de saída pela tensão de entrada  $F(s)$ :

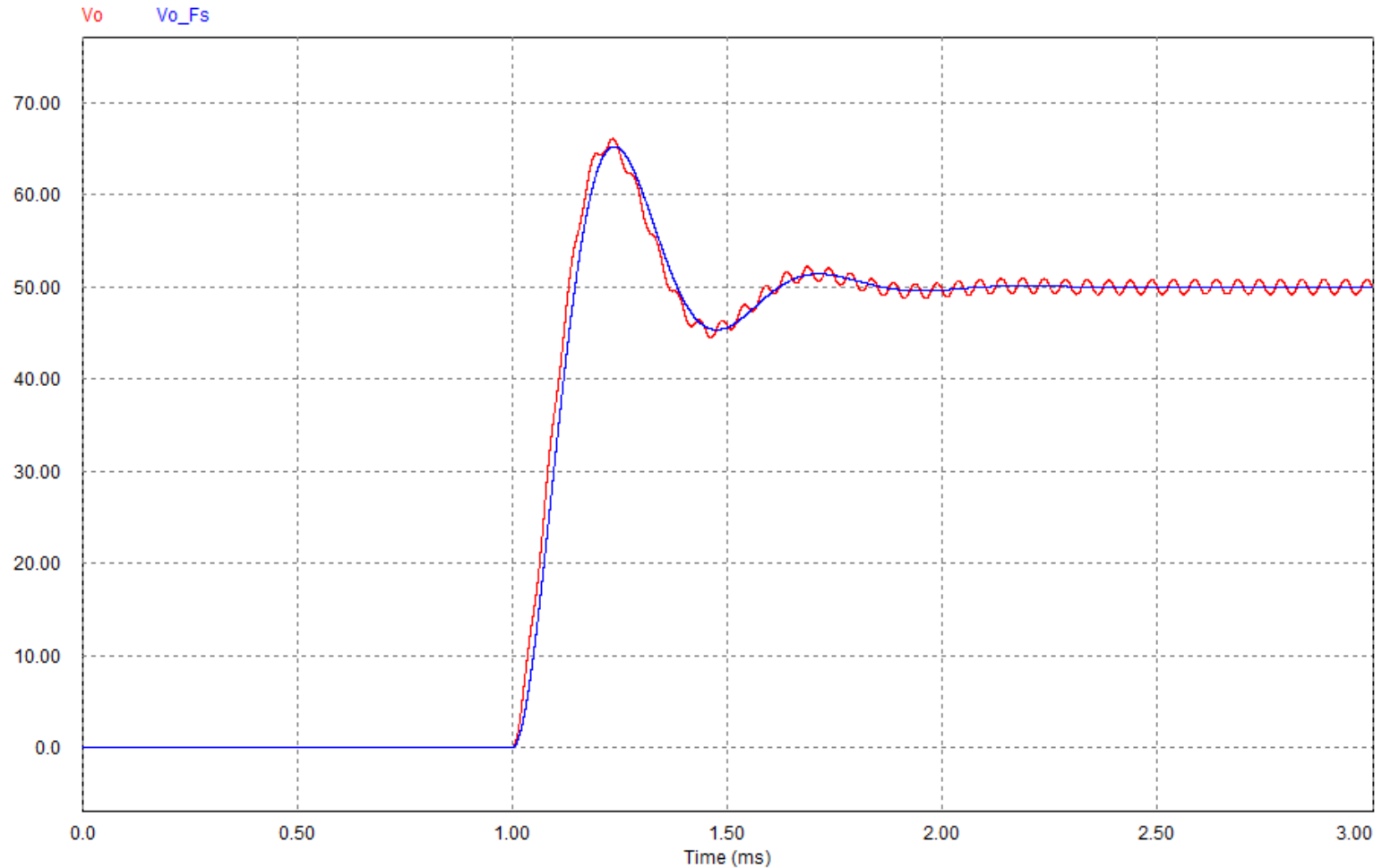

# Diagrama de blocos do conversor

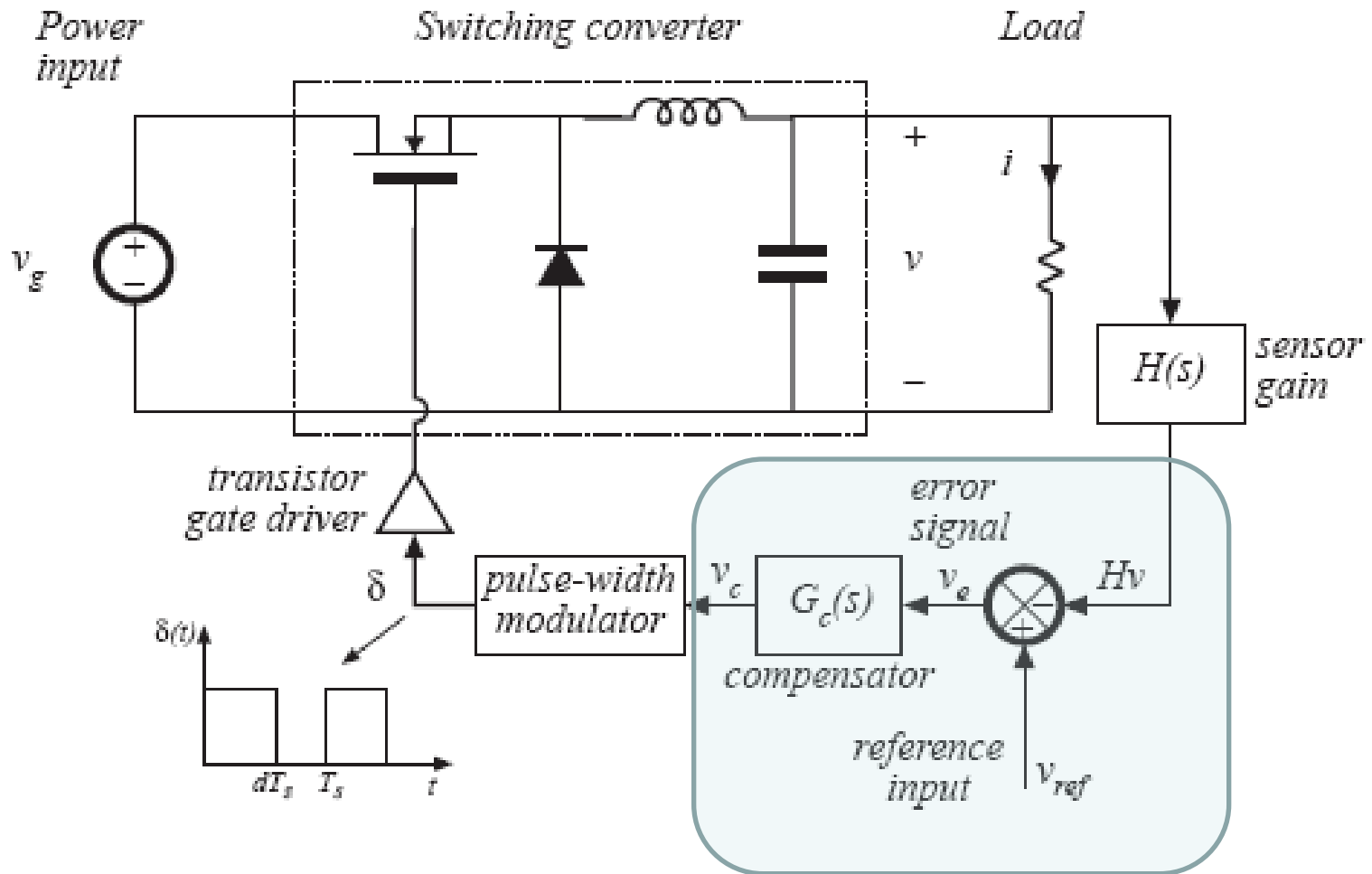

# Diagrama de blocos do conversor

$$F(s) = \frac{v_o(s)}{v_i(s)} \Big|_{\hat{d}=0} = \frac{D \cdot R_o}{s^2 \cdot L_o \cdot C_o \cdot R_o + s \cdot L_o + R_o}$$

$$G(s) = \frac{v_o(s)}{d(s)} \Big|_{\hat{v}_i=0} = \frac{V_i \cdot R_o}{s^2 \cdot L_o \cdot C_o \cdot R_o + s \cdot L_o + R_o}$$

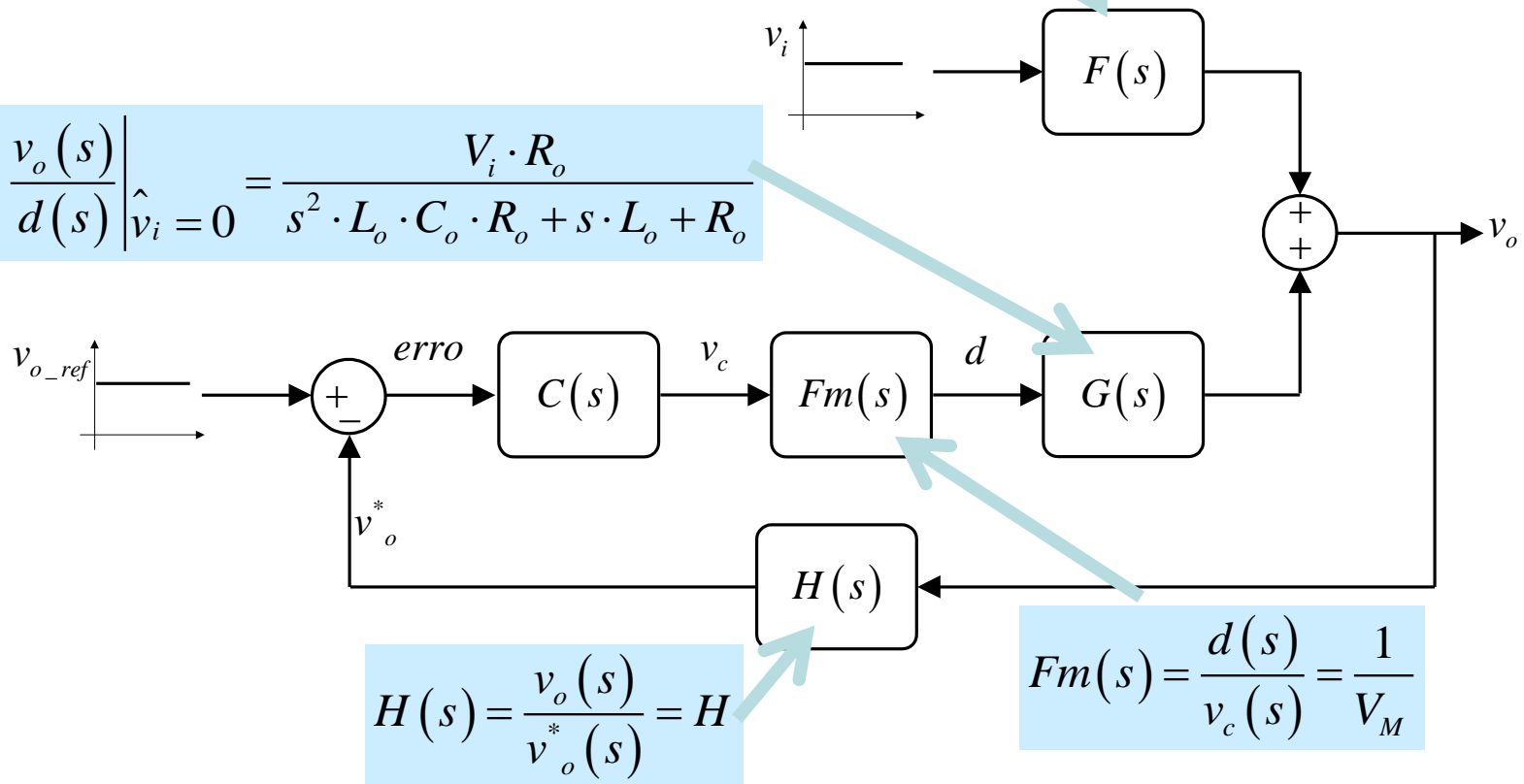

$$H(s) = \frac{v_o(s)}{v_o^*(s)} = H$$

$$F_m(s) = \frac{d(s)}{v_c(s)} = \frac{1}{V_M}$$

# Função de transferência de laço aberto FTLA(s)

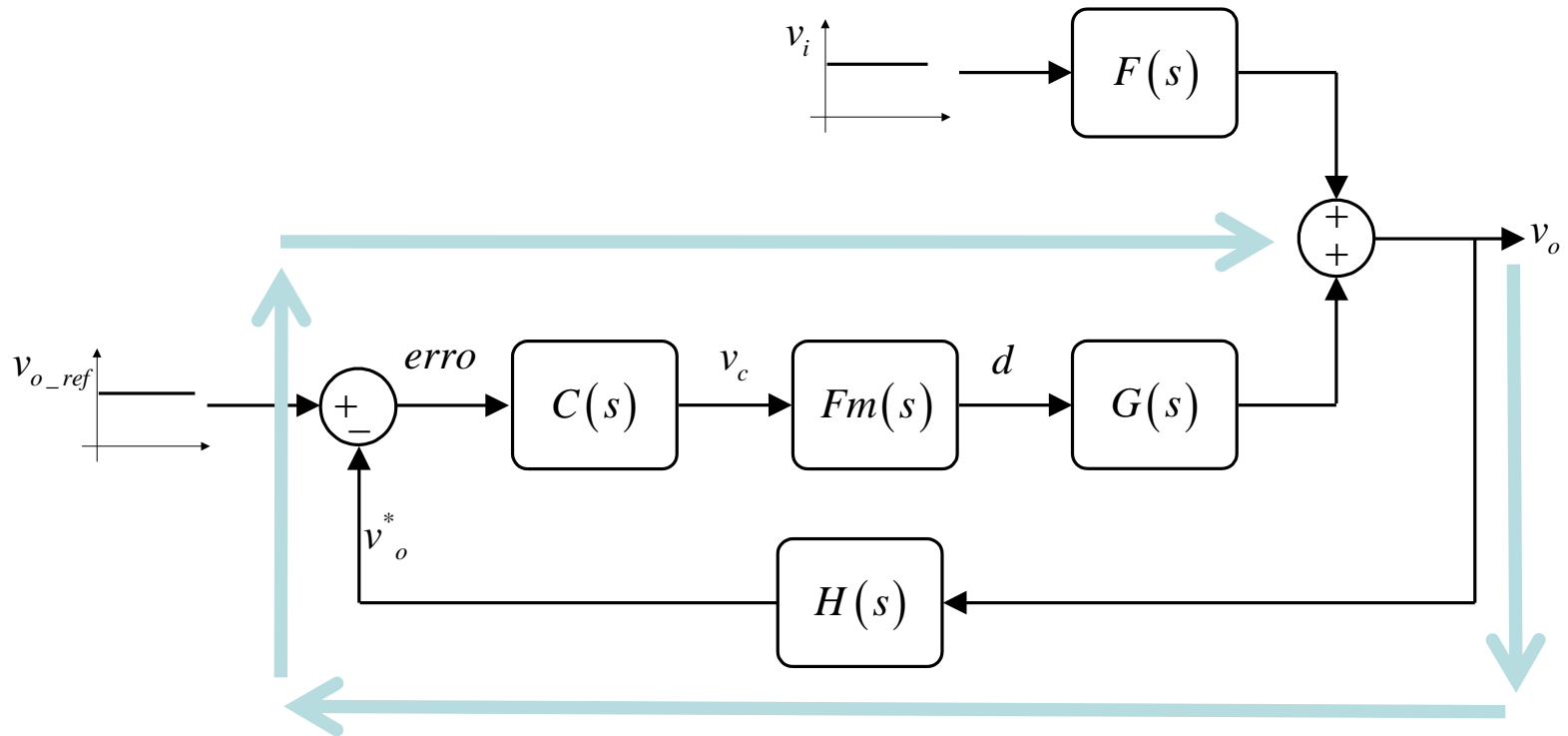

$$FTLA(s) = G(s) \cdot H(s) \cdot C(s) \cdot Fm(s)$$

# Função de transferência de malha fechada FTMF(s)

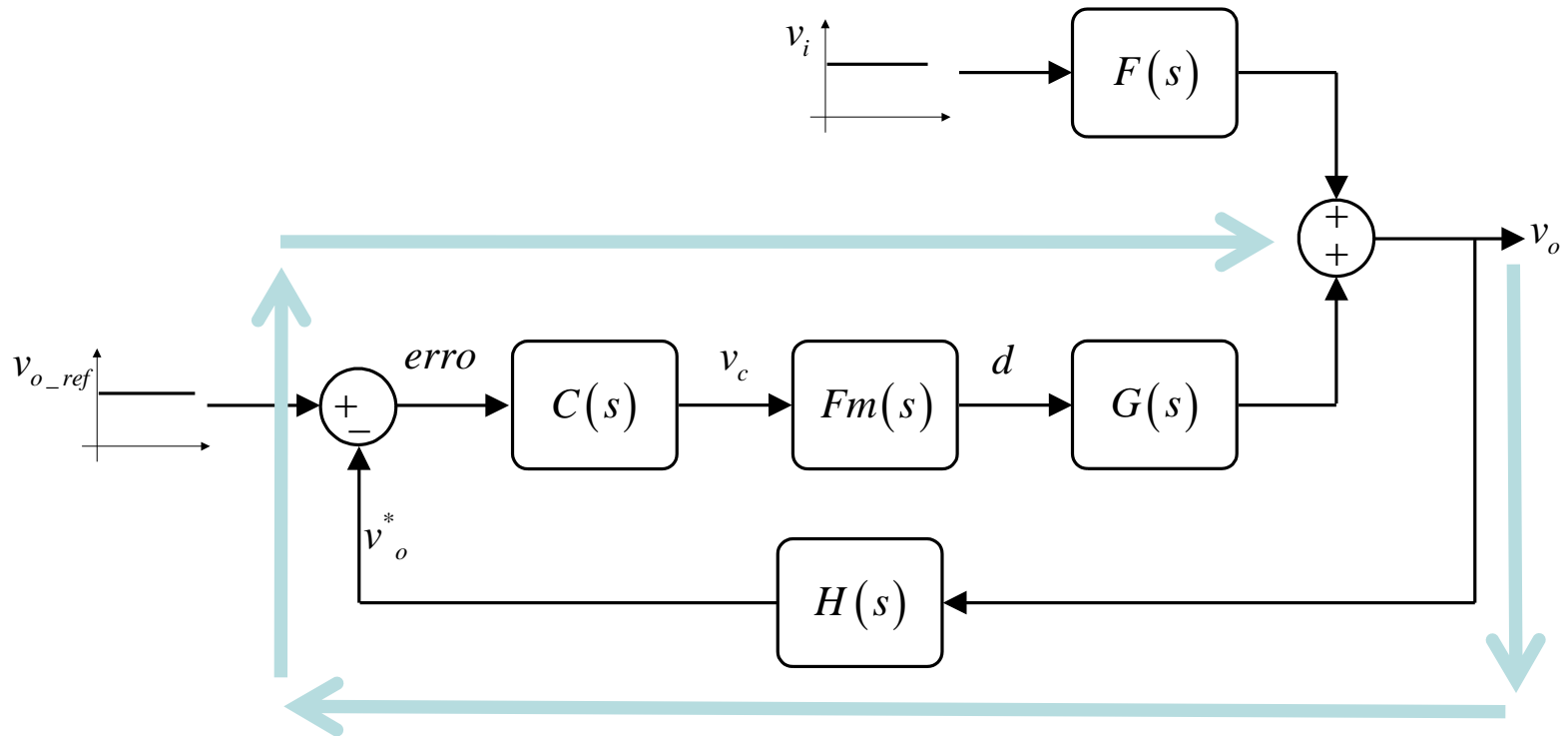

$$FTMF(s) = \frac{G(s) \cdot C(s) \cdot Fm(s)}{1 + G(s) \cdot H(s) \cdot C(s) \cdot Fm(s)}$$

# Metodologia de projeto do controlador

## Metodologia para determinar o compensador de tensão PID:

1. Colocar um pólo na origem;
2. Posicionar os dois zeros na freqüência de ressonância do filtro de saída;
3. Colocar o outro pólo bem acima da freqüência de ressonância do filtro de saída;
4. Ajustar o ganho para a freqüência de cruzamento desejada, por exemplo  $F_s/8$ .

$$C(s) = \frac{v_c(s)}{\text{erro}(s)} = k \cdot \frac{(1 + s \cdot z_1) \cdot (1 + s \cdot z_2)}{s \cdot (1 + s \cdot p_2)}$$

The equation is annotated with blue boxes containing numbers 1, 2, 3, and 4, corresponding to the steps in the methodology:

- Box 1 is under the pole  $s$ .
- Box 2 is under the first zero  $z_1$ .
- Box 3 is under the second pole  $p_2$ .
- Box 4 is under the gain  $k$ .

# Metodologia de projeto do controlador

## Exemplo de projeto:

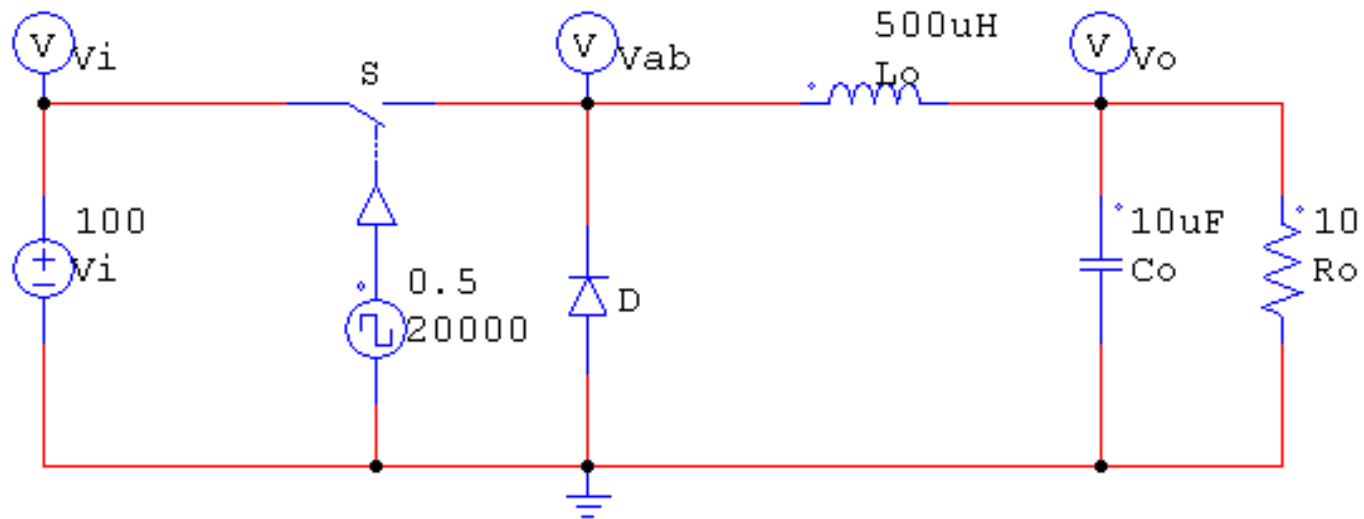

$$V_i = 100V$$

$$L_o = 500\mu H$$

$$G(s) = \frac{1000}{s^2 \cdot 50 \cdot 10^{-9} + s \cdot 500 \cdot 10^{-6} + 10}$$

$$V_o = 50V$$

$$C_o = 10\mu F$$

$$D = 0,5$$

$$R_o = 10\Omega$$

$$F(s) = \frac{5}{s^2 \cdot 50 \cdot 10^{-9} + s \cdot 500 \cdot 10^{-6} + 10}$$

$$F_s = 20kHz$$

# Metodologia de projeto do controlador

Exemplo de projeto:

$$Fm(s) = \frac{1}{5} = 0,2$$

$$H(s) = \frac{5}{50} = 0,1$$

$$FTLA(s) = \frac{20}{s^2 \cdot 50 \cdot 10^{-9} + s \cdot 500 \cdot 10^{-6} + 10}$$

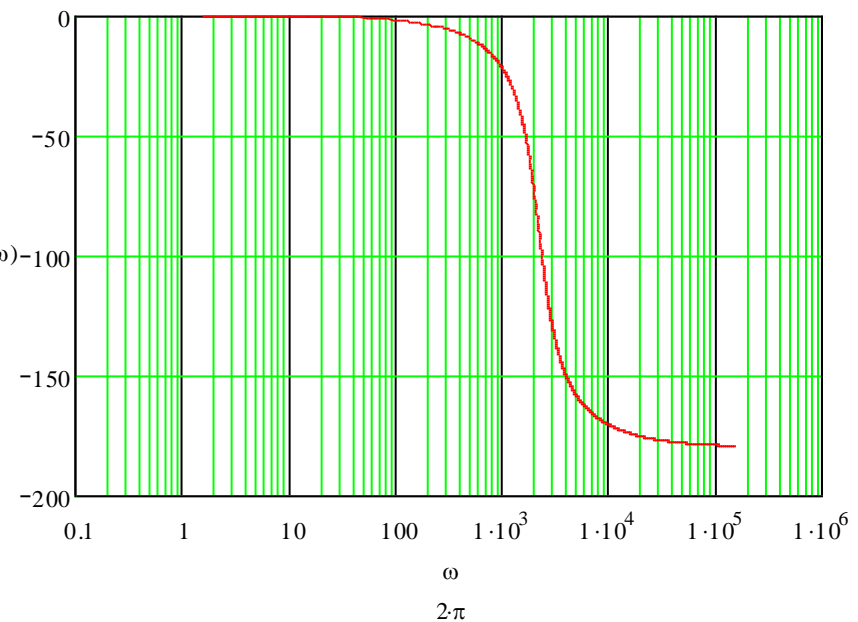
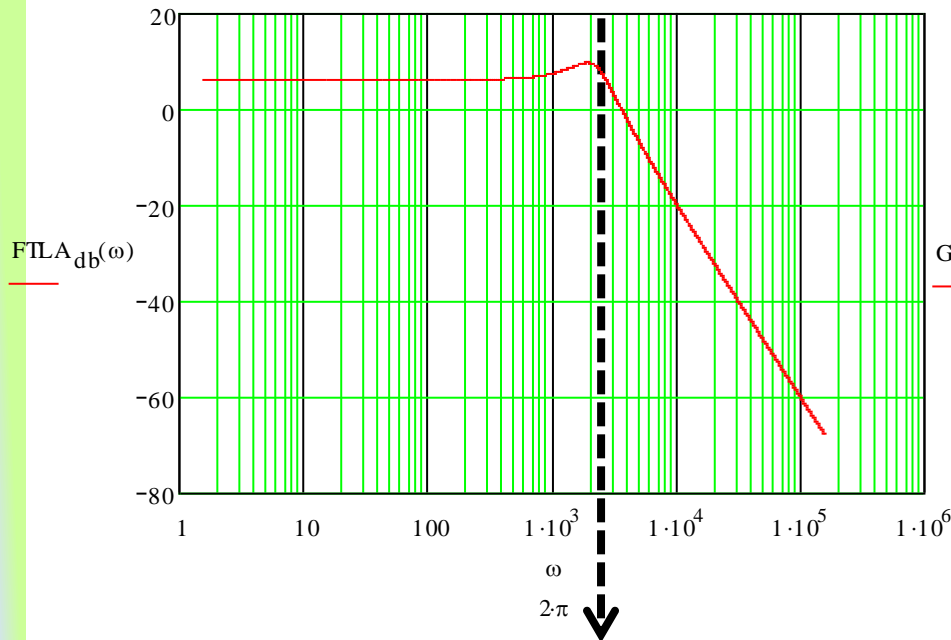

$$F_c = \frac{F_s}{8} = \frac{20000}{8} = 2500 \text{ Hz}$$

# Metodologia de projeto do controlador

## Exemplo de projeto:

$$F_o = \frac{1}{2\pi\sqrt{L_o \cdot C_o}} = \frac{1}{2\pi\sqrt{500\mu \cdot 10\mu}} = 2251 \text{ Hz}$$

$$F_{z1} = F_o = 2251 \text{ Hz}$$

$$F_{z2} = F_o = 2251 \text{ Hz}$$

$$F_{p1} = 0 \text{ Hz}$$

$$F_{p2} = 9 \cdot F_o = 20260 \text{ Hz}$$

$$k = 3000$$

$$C(s) = k \cdot \frac{(1 + s \cdot z_1) \cdot (1 + s \cdot z_2)}{s \cdot (1 + s \cdot p_2)}$$

$$C(s) = 60 \cdot \frac{\left(1 + s \cdot \frac{1}{2\pi \cdot 2251}\right) \cdot \left(1 + s \cdot \frac{1}{2\pi \cdot 2251}\right)}{s \cdot \left(1 + s \cdot \frac{1}{2\pi \cdot 20260}\right)}$$

$$C(s) = 60 \cdot \frac{(1 + s \cdot 70 \cdot 10^{-6}) \cdot (1 + s \cdot 70 \cdot 10^{-6})}{s \cdot (1 + s \cdot 7,86 \cdot 10^{-6})}$$

# Metodologia de projeto do controlador

## Exemplo de projeto:

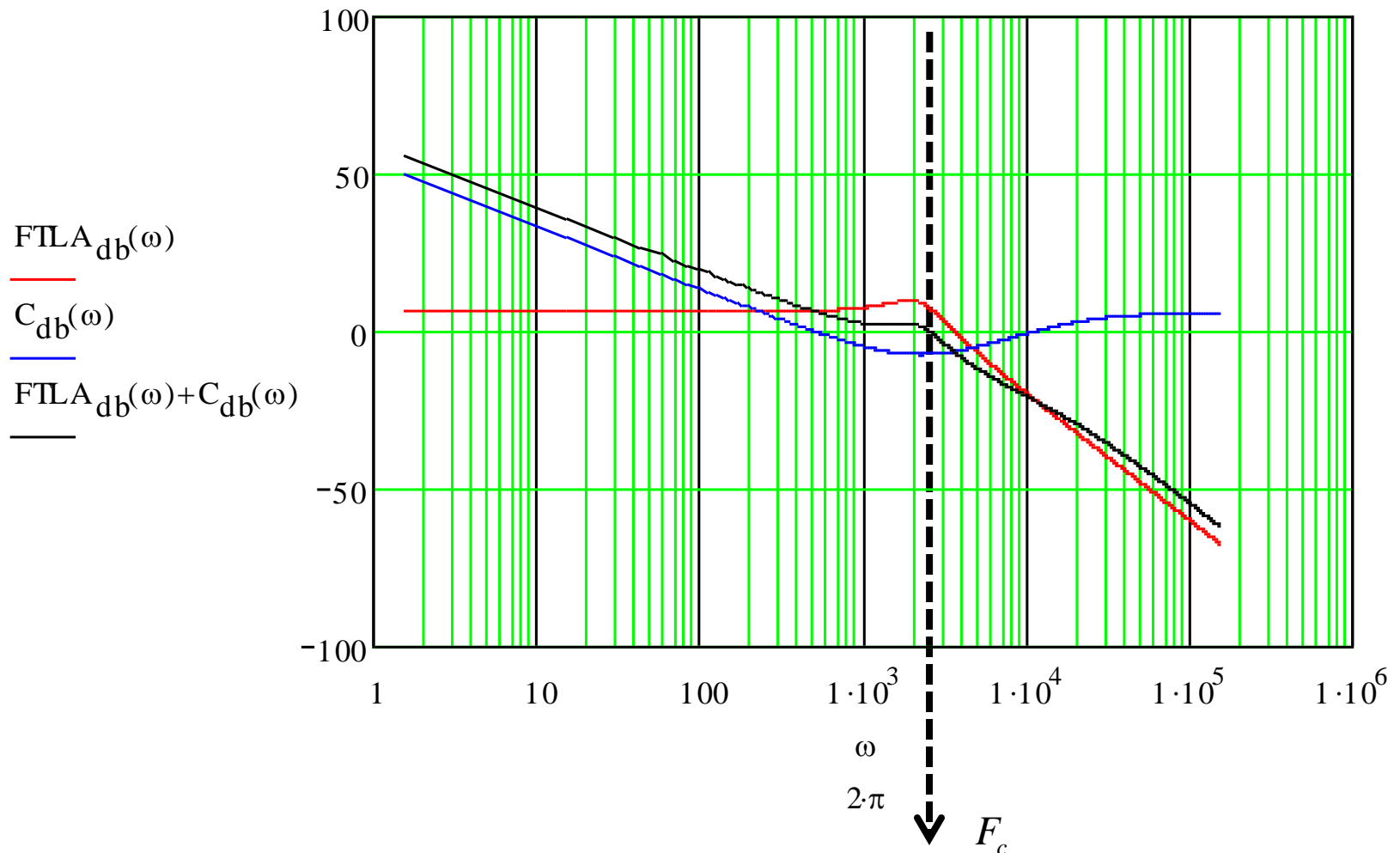

# Metodologia de projeto do controlador

## Exemplo de projeto:

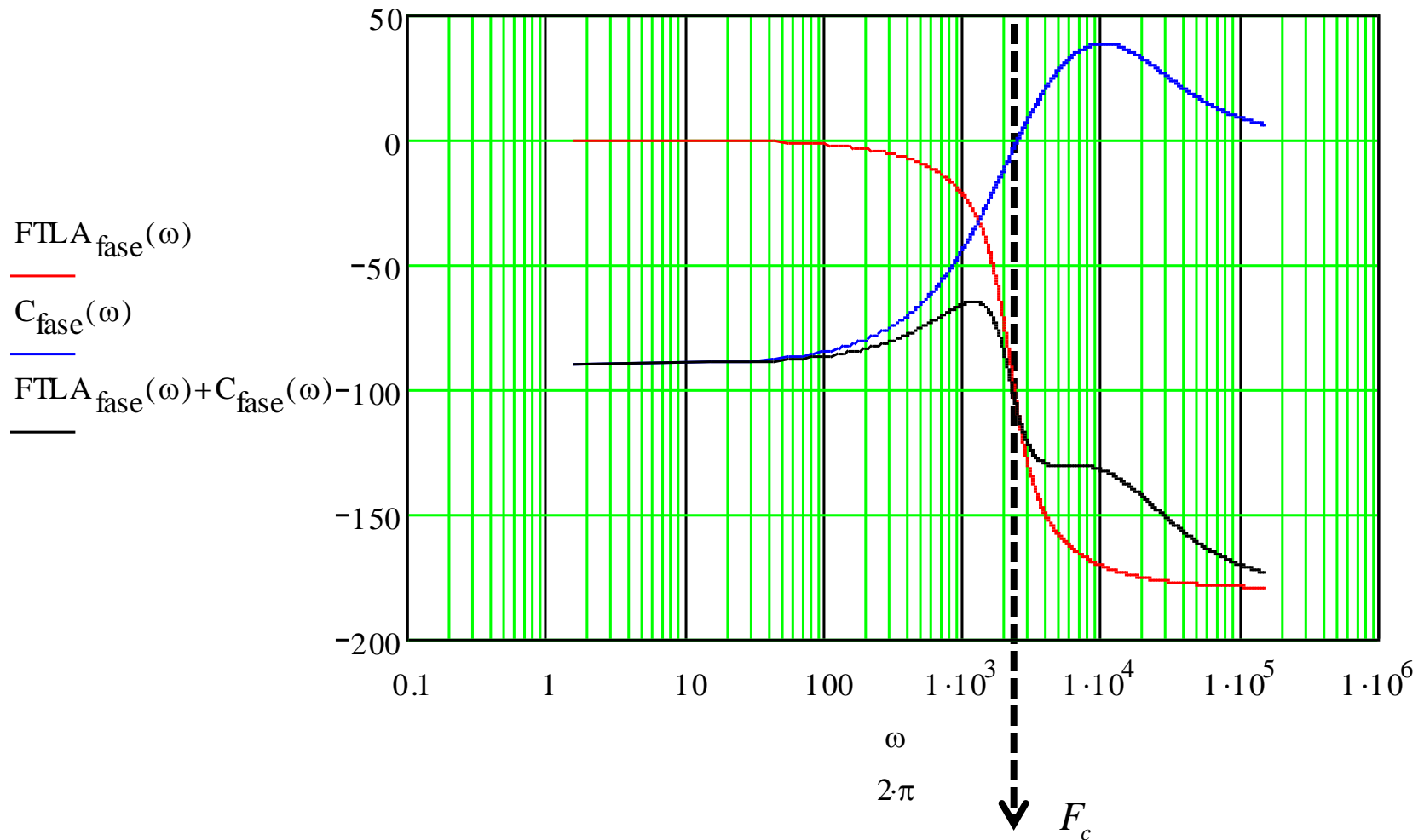

# Metodologia de projeto do controlador

## Exemplo de projeto:

$$MF = 180^\circ + FTLA_{fase}(\omega_c) + C_{fase}(\omega_c)$$

$$MF = 180^\circ - 106,57^\circ + 6,65^\circ$$

$$MF = 80^\circ$$

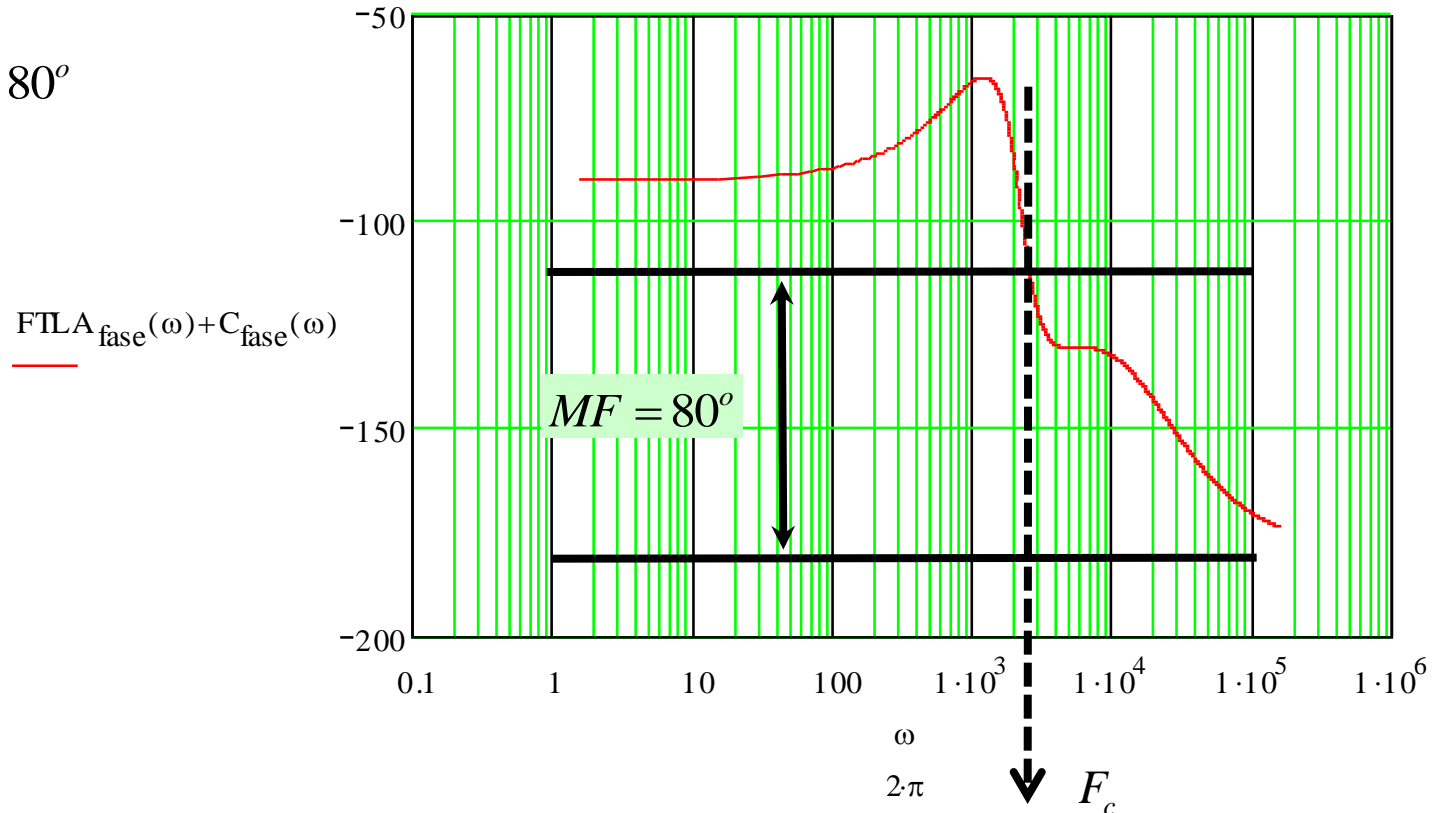

# Implementação do sensor de tensão da saída

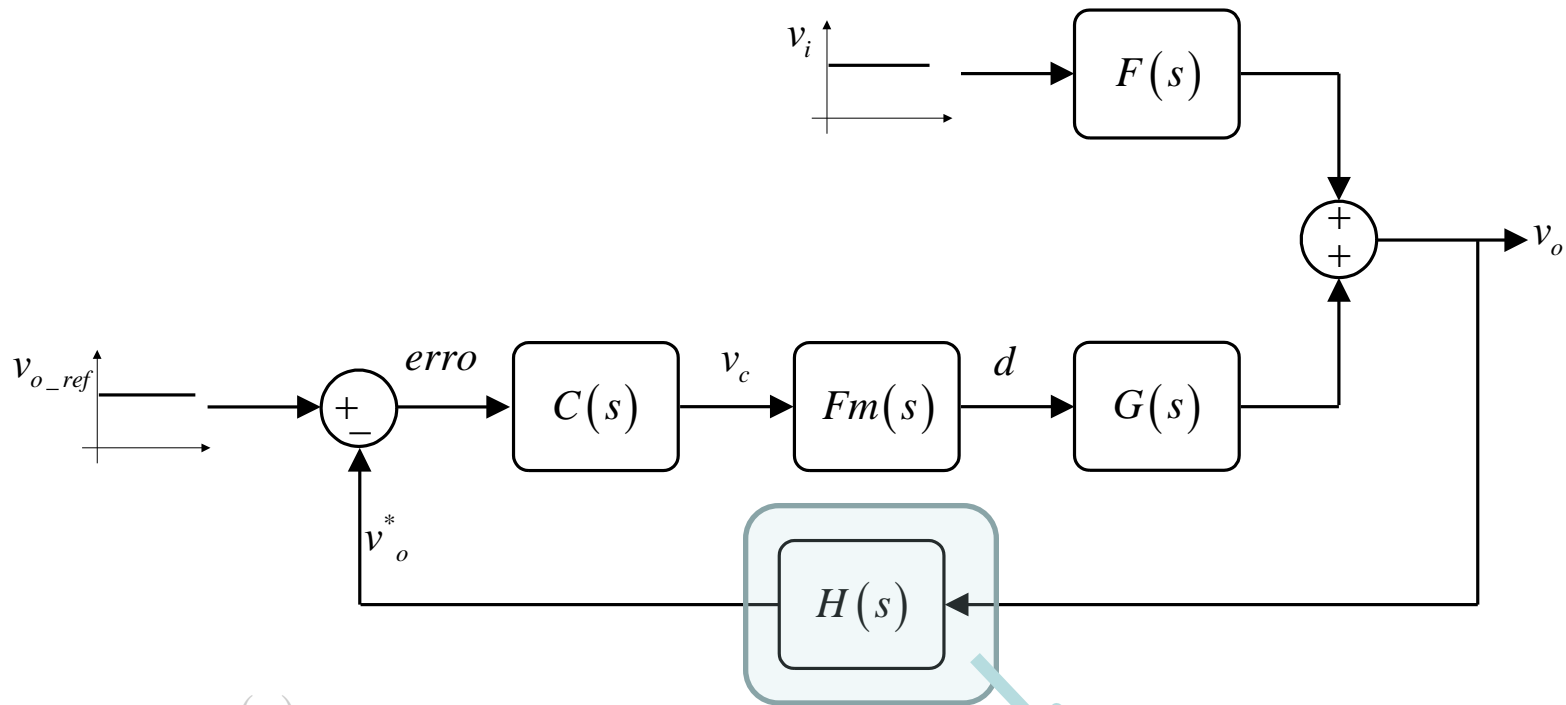

$$H(s) = \frac{v_o(s)}{v_o^*(s)} = \frac{R_b}{R_a + R_b} = H$$

$$R_a = 10\text{k}\Omega \quad R_b = \frac{R_a \cdot H}{1 - H} = \frac{10\text{k} \cdot 0,1}{1 - 0,1} = 1,1\text{k}\Omega$$

$$R_b = 1\text{k}\Omega$$

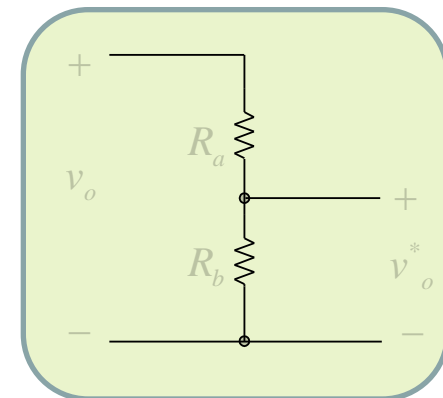

# Implementação do controlador

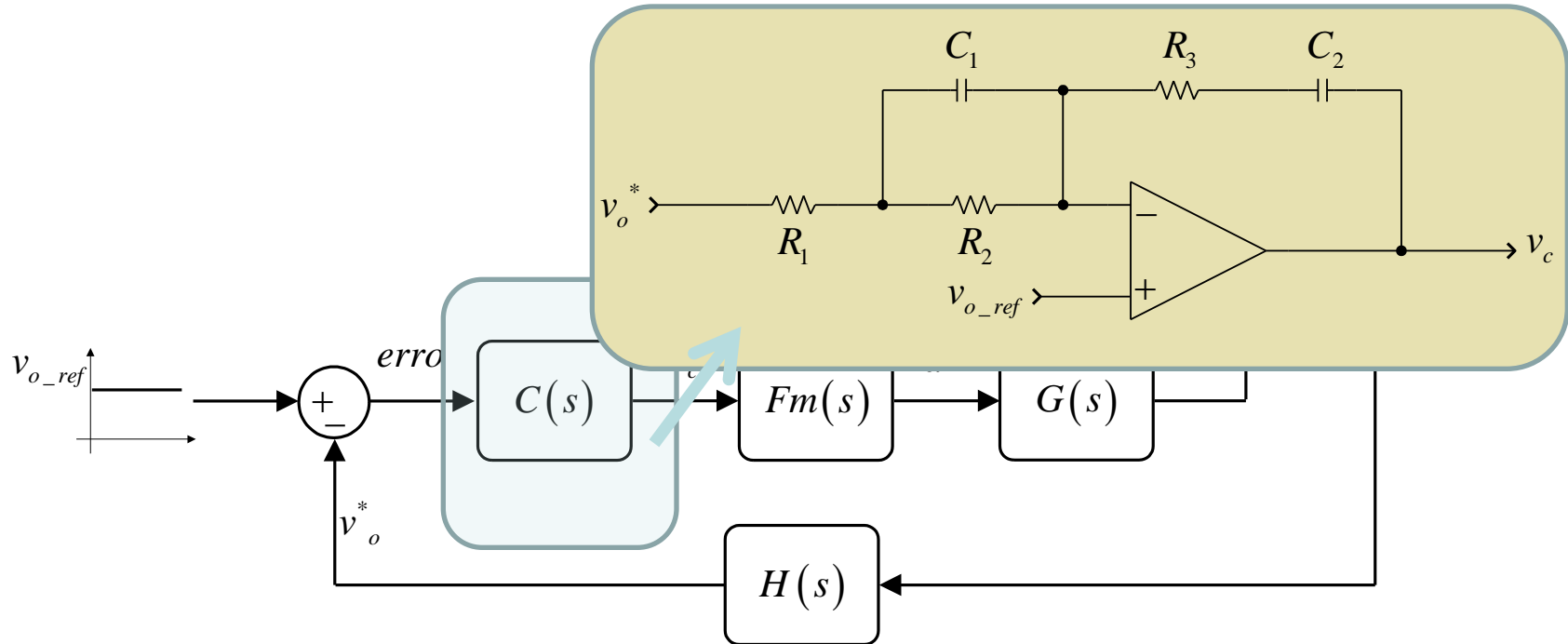

$$C(s) = \frac{v_c(s)}{erro(s)} = k \cdot \frac{(1 + s \cdot z_1) \cdot (1 + s \cdot z_2)}{s \cdot (1 + s \cdot p_2)}$$

$$R_2 = \frac{z_1}{C_1} \quad R_3 = \frac{z_2}{C_2}$$

$$R_1 = \frac{-p_2 \cdot R_2}{(p_2 - C_1 \cdot R_2)}$$

$$C(s) = \frac{1}{C_2 \cdot (R_1 + R_2)} \cdot \frac{(1 + s \cdot C_1 \cdot R_2) \cdot (1 + s \cdot C_2 \cdot R_3)}{s \cdot \left( 1 + s \cdot C_1 \cdot \frac{R_1 \cdot R_2}{R_1 + R_2} \right)}$$

$$C_2 = \frac{1}{k \cdot (R_1 + R_2)}$$

# Implementação do controlador

$$C_1 = 10 \text{ nF}$$

$$R_2 = \frac{z_1}{C_1} = 7 \text{ k}\Omega \longrightarrow R_2 = 6,8 \text{ k}\Omega$$

$$R_1 = \frac{-p_2 \cdot R_2}{(p_2 - C_1 \cdot R_2)} = 888 \Omega \longrightarrow R_1 = 820 \Omega$$

$$C_2 = \frac{1}{k \cdot (R_1 + R_2)} = 43,7 \text{ nF} \longrightarrow C_2 = 44 \text{ nF}$$

$$R_3 = \frac{z_2}{C_2} = 2,9 \text{ k}\Omega \longrightarrow R_3 = 3,3 \text{ k}\Omega$$

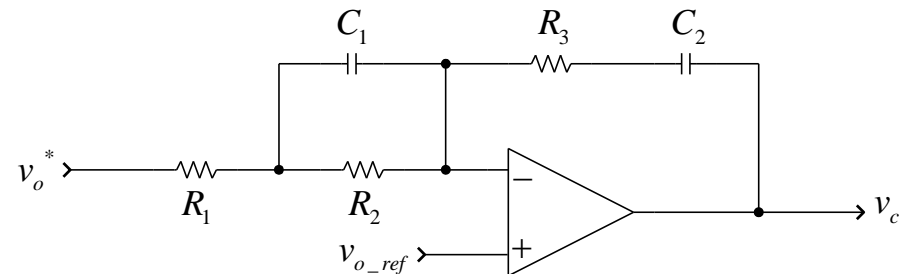

# Verificação por simulação

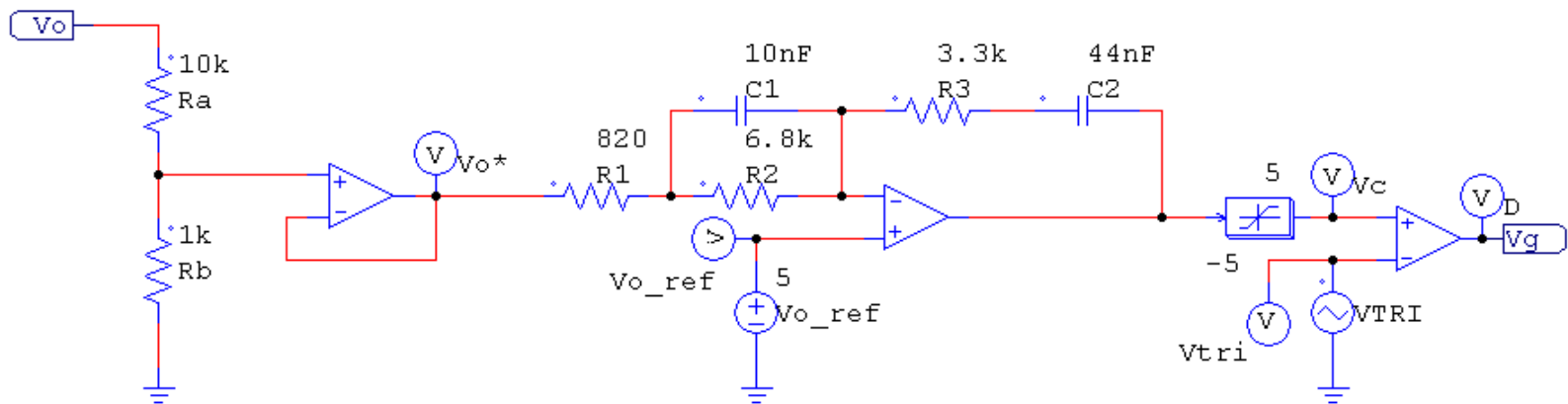
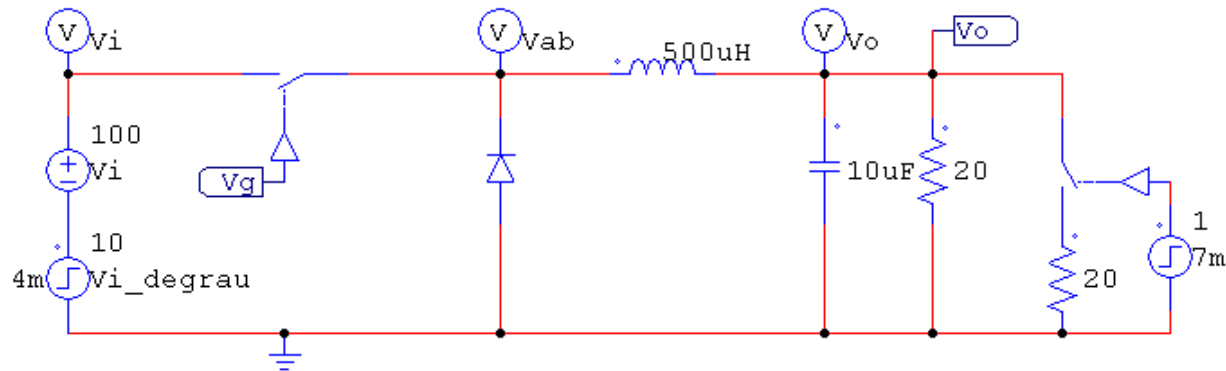

# Verificação por simulação

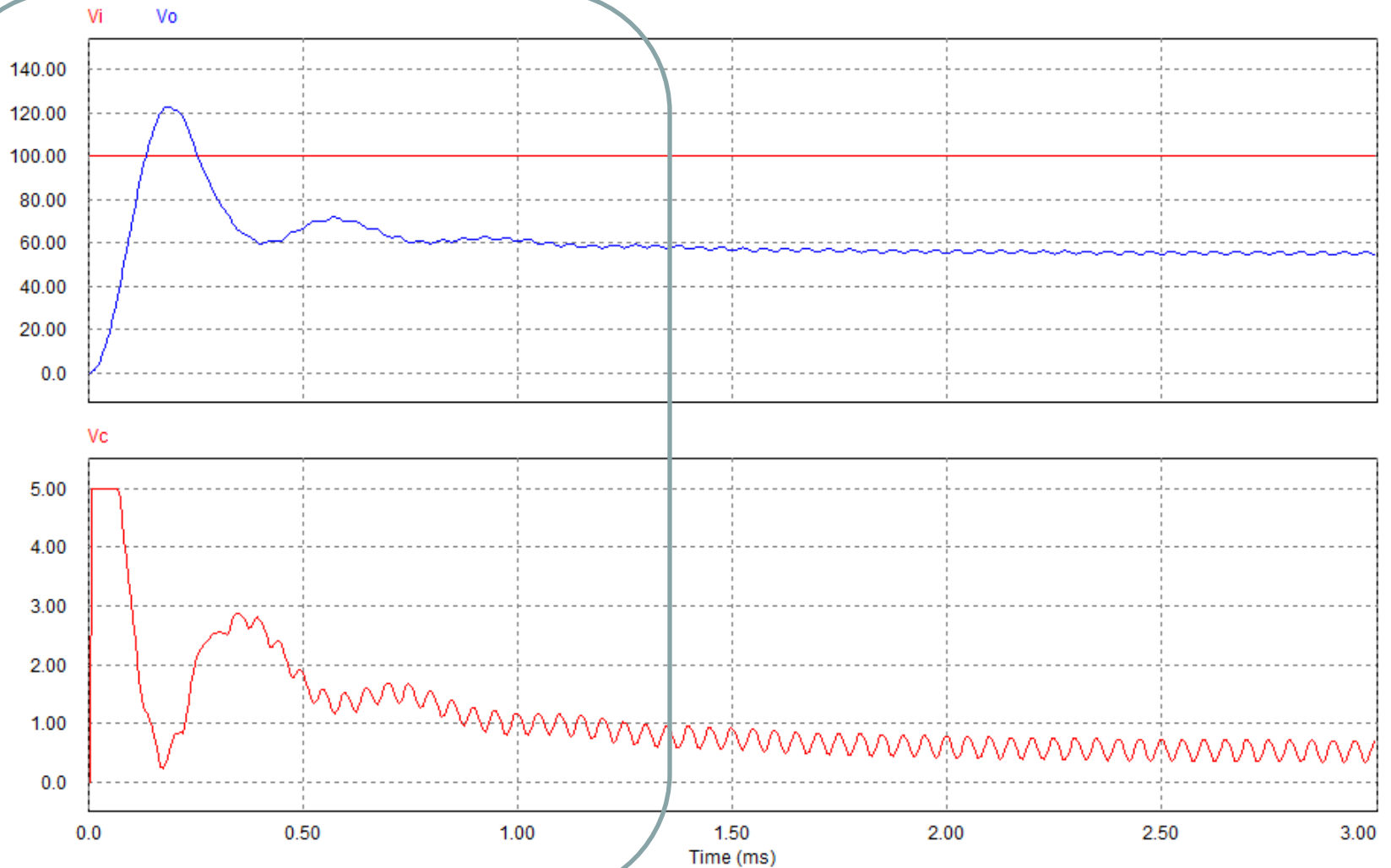

Partida do conversor

# Verificação por simulação

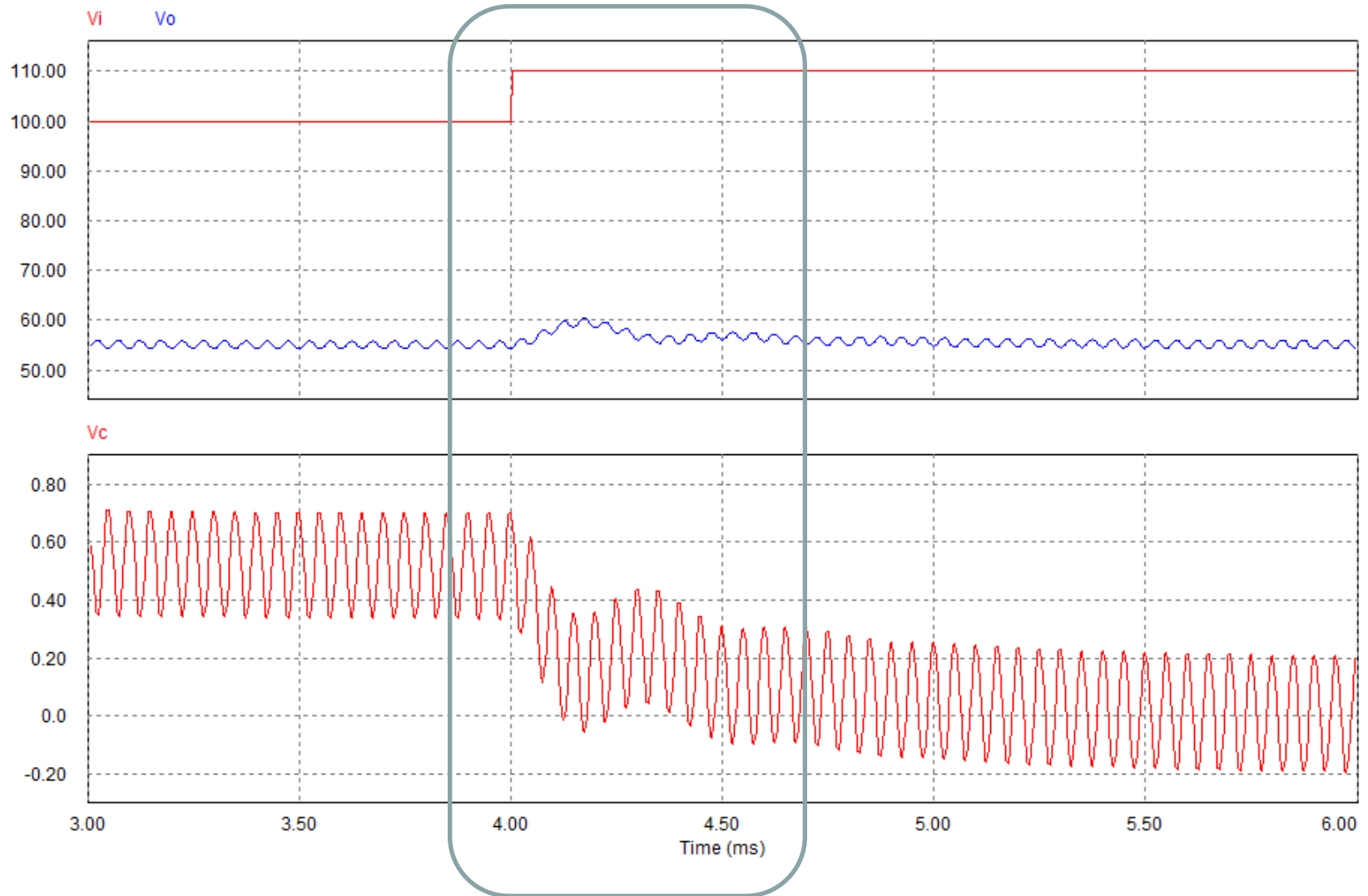

Transitório na tensão de entrada

# Verificação por simulação

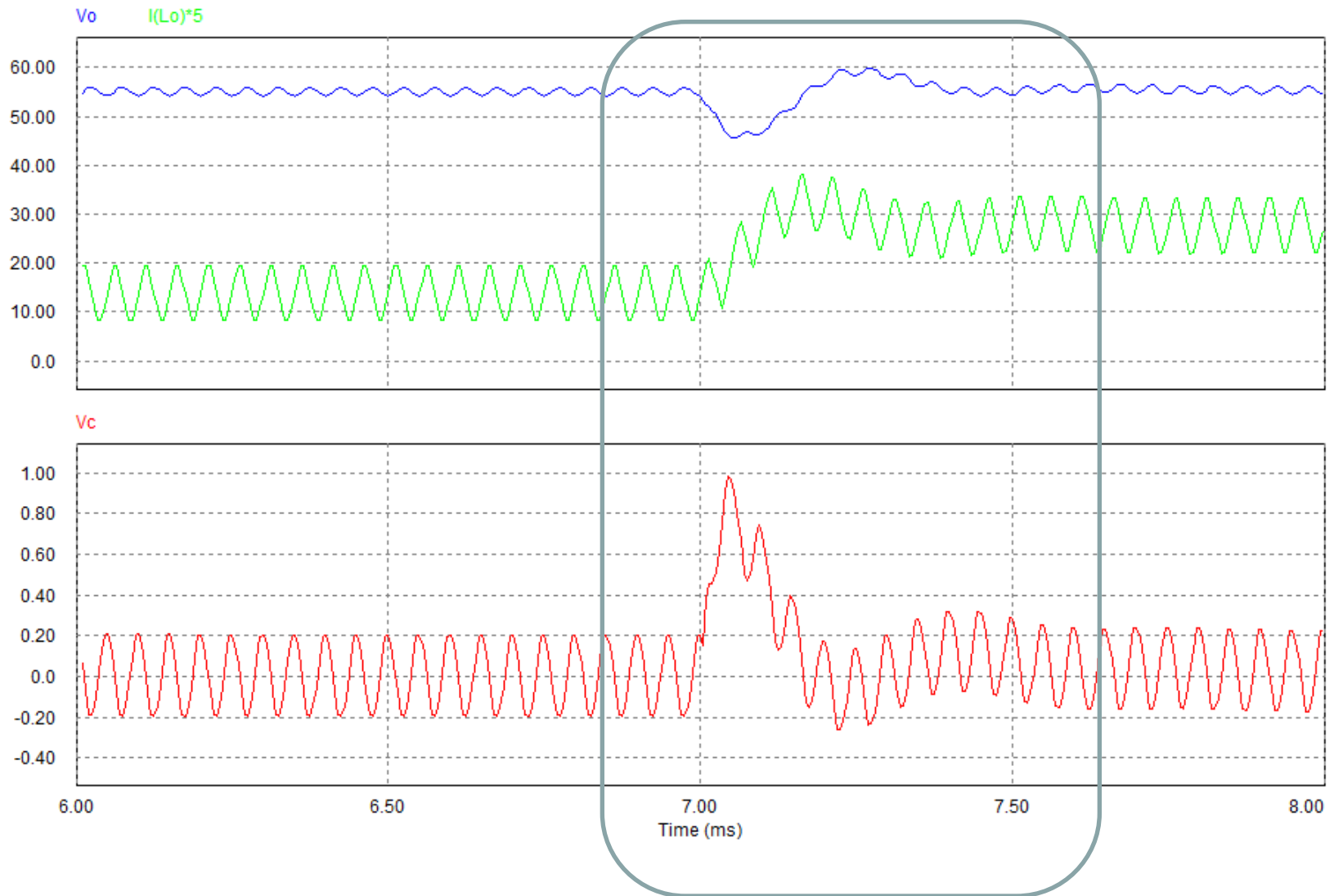

Transitório na carga

# Próxima aula

## **Parte 2 – Fontes mistas:**

1. Projeto de um conversor CC-CC.