

Centro Federal de Educação Tecnológica de Santa Catarina
Departamento de Eletrônica
Retificadores



Reguladores de Tensão

Prof. Clóvis Antônio Petry.

Florianópolis, dezembro de 2007.

Na próxima aula

Seqüência de conteúdos:

1. Reguladores de tensão.

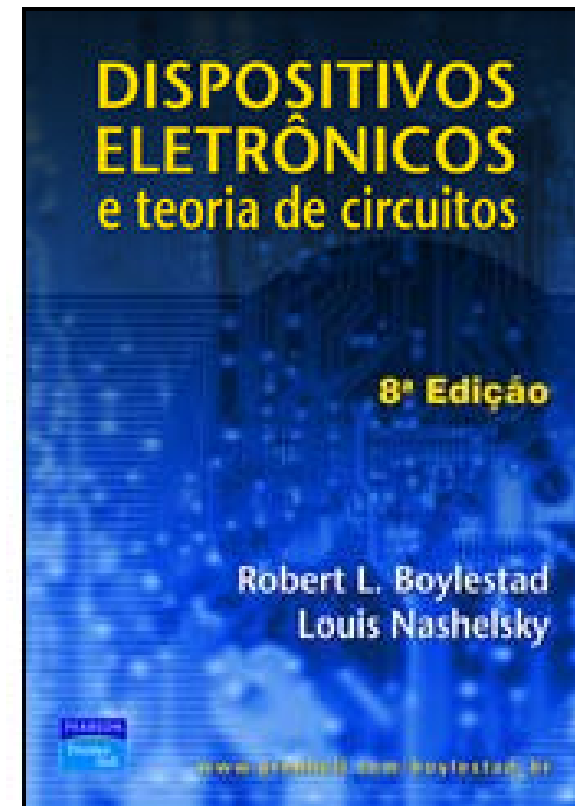
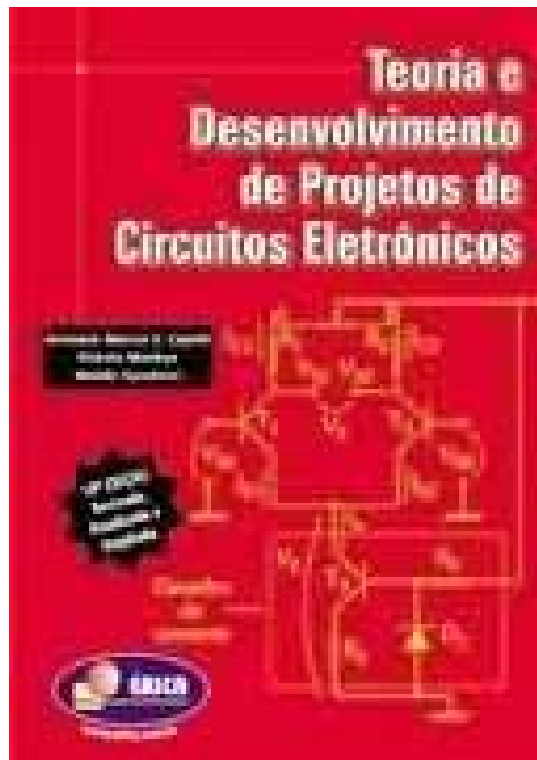

Nesta aula

Seqüência de conteúdos:

1. Introdução;
2. Regulação de tensão a transistor;
3. Regulador série a transistor em malha aberta;
4. Regulador série a transistor em malha fechada;
5. Regulador série com amplificador operacional;
6. Limitação de corrente;
7. CIs reguladores de tensão;
8. Regulador série de tensão positiva fixa;
9. Regulador série de tensão negativa fixa;
10. Especificações de um regulador;
11. Reguladores de tensão ajustável.

Introdução

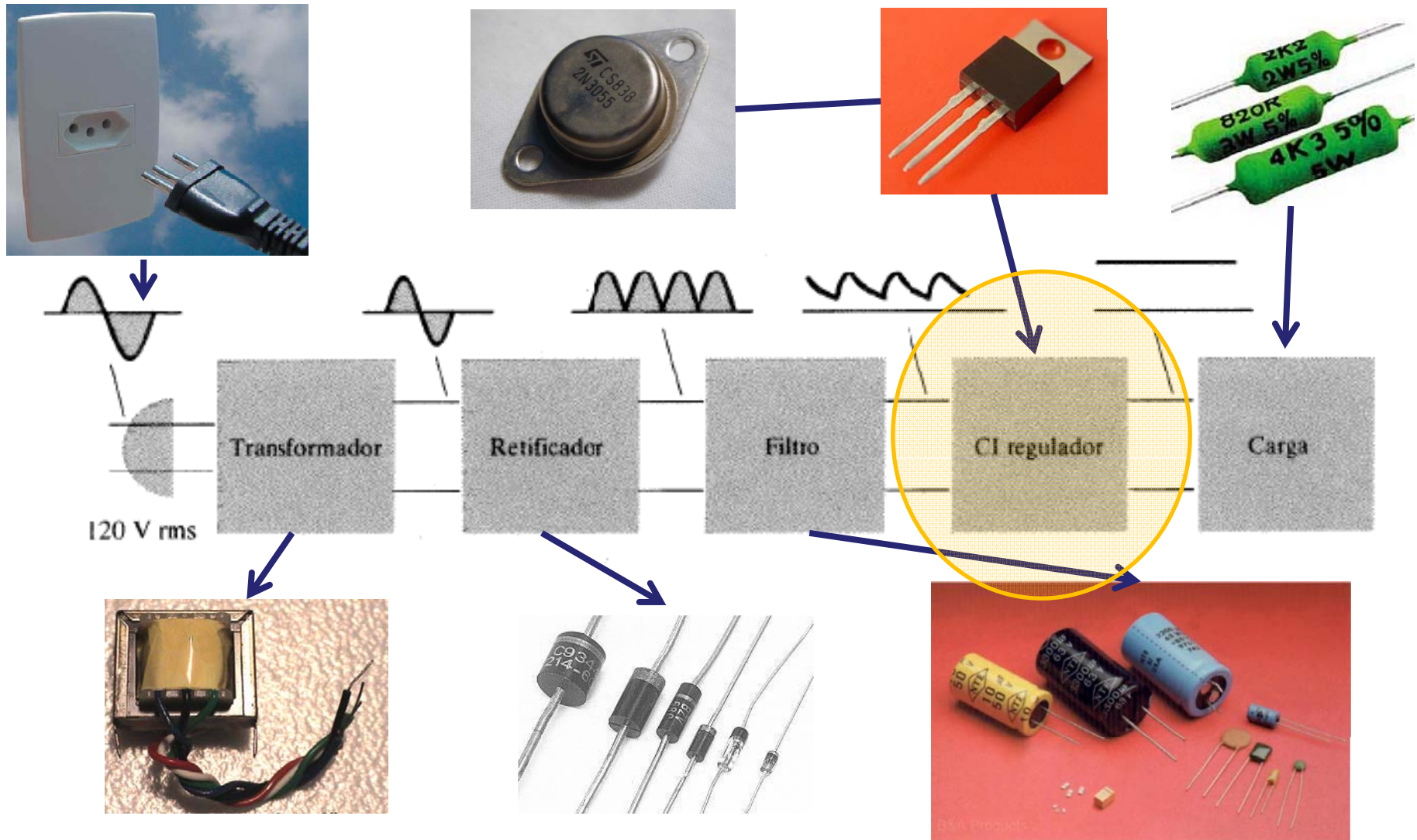

Regulação de tensão a transistor

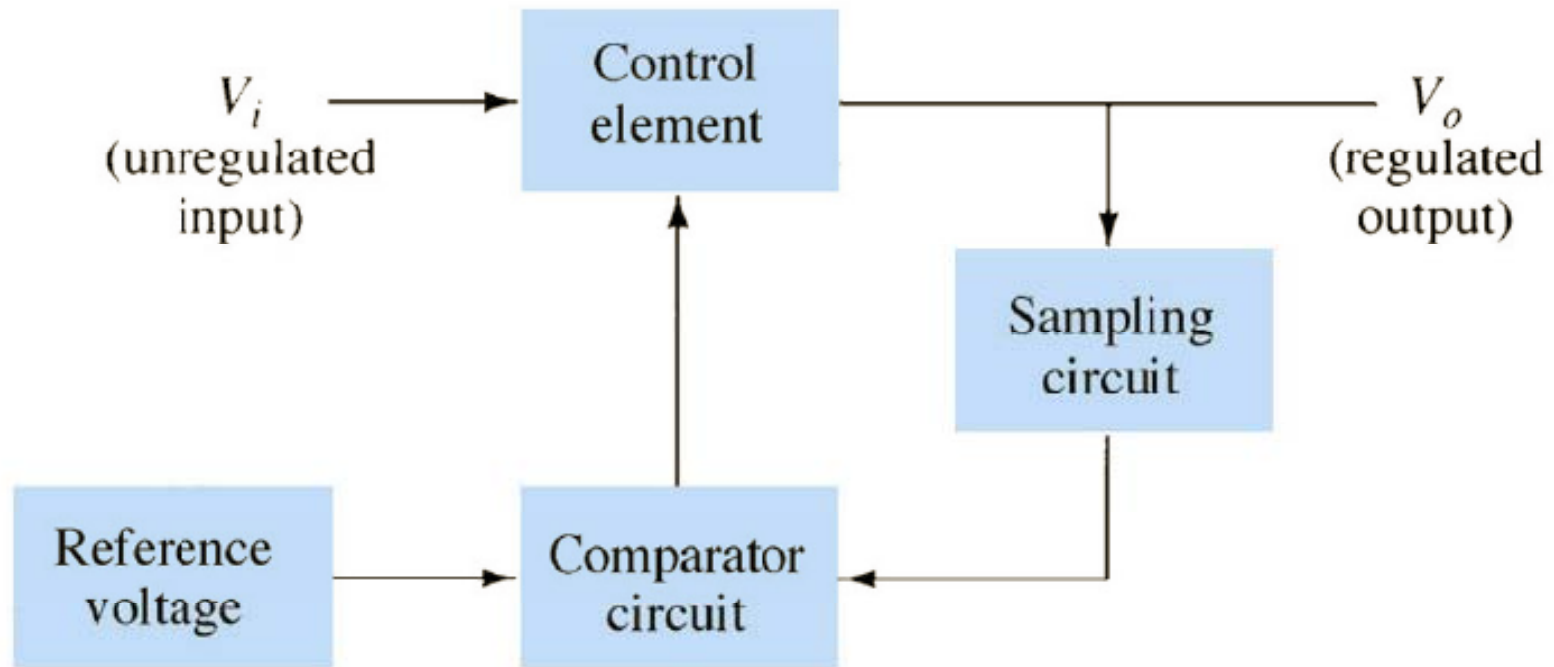

Princípio da regulação série.

Regulador série a transistor em malha aberta

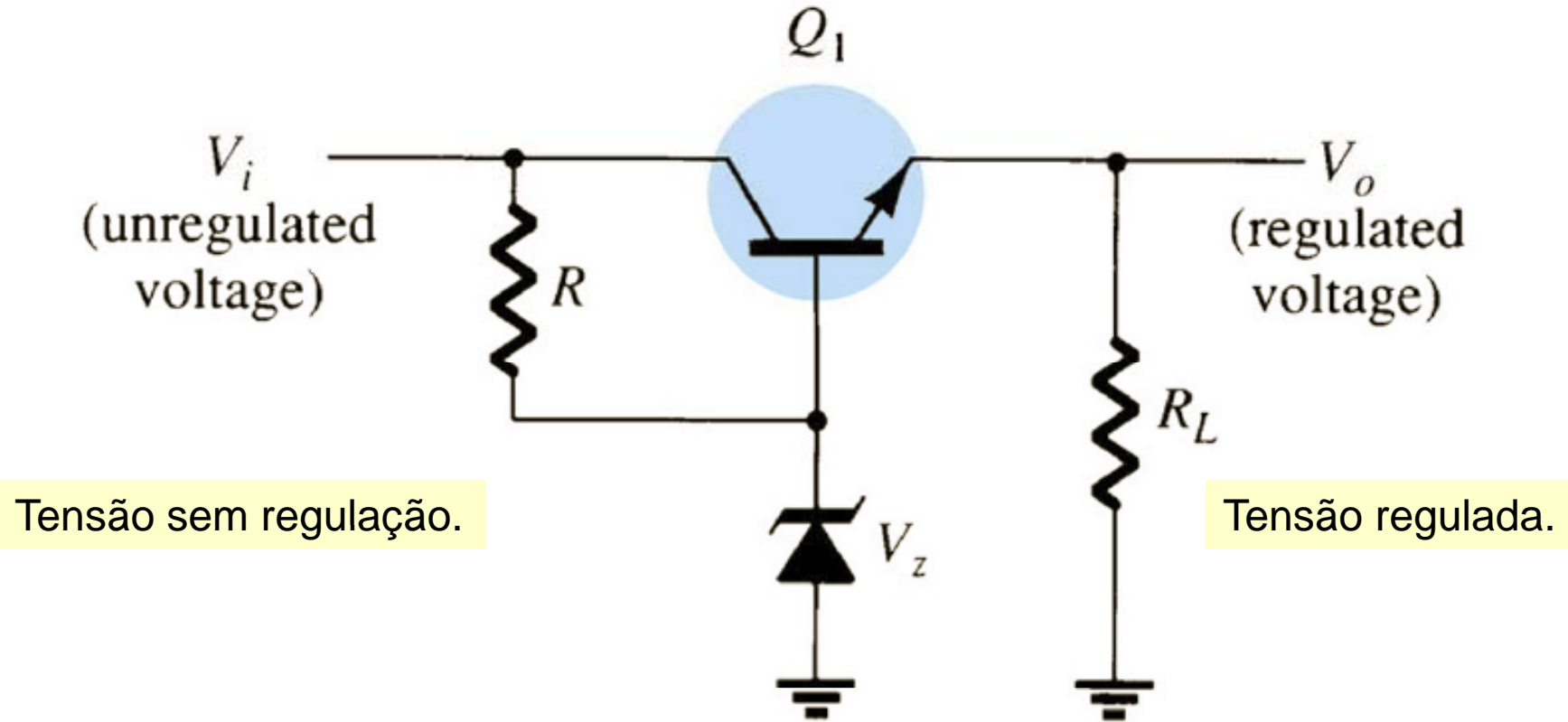

Regulador série a transistor em malha fechada

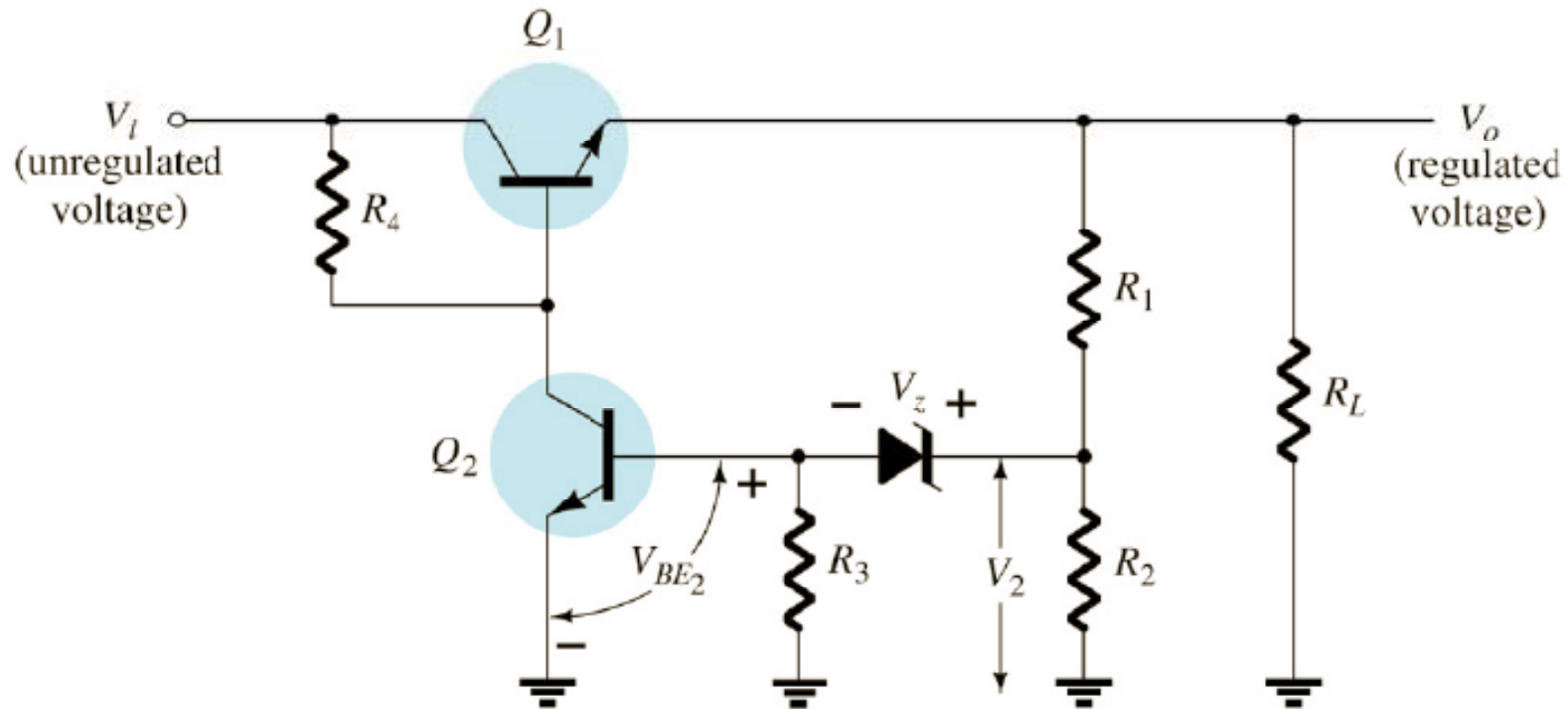

$$V_{BE2} + V_Z = V_2 = \frac{R_2}{R_1 + R_2} V_o$$

$$V_o = \frac{R_1 + R_2}{R_2} (V_Z + V_{BE2})$$

Regulador série com amplificador operacional

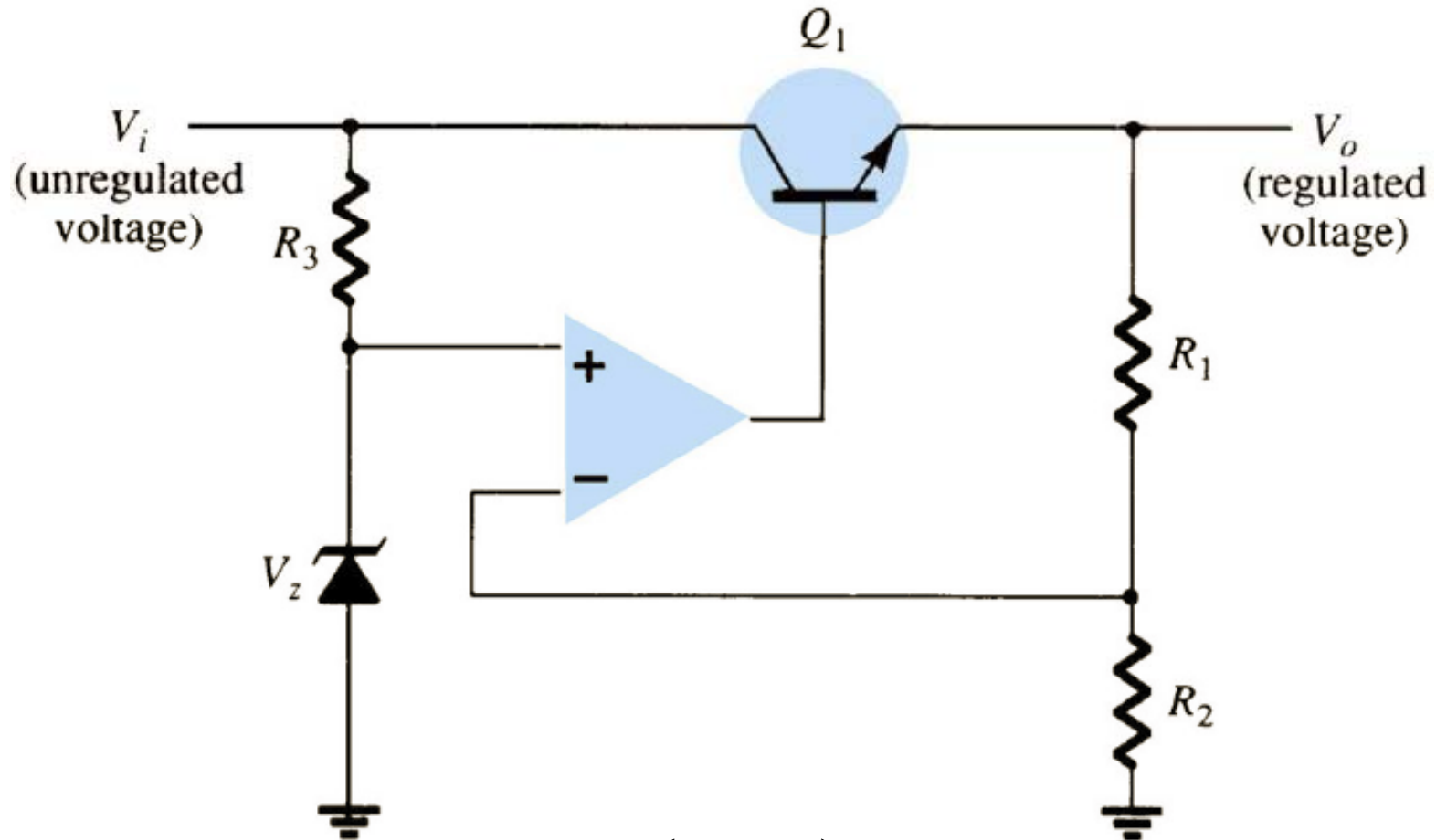

$$V_o = \left(1 + \frac{R_1}{R_2} \right) V_z$$

Limitação de corrente

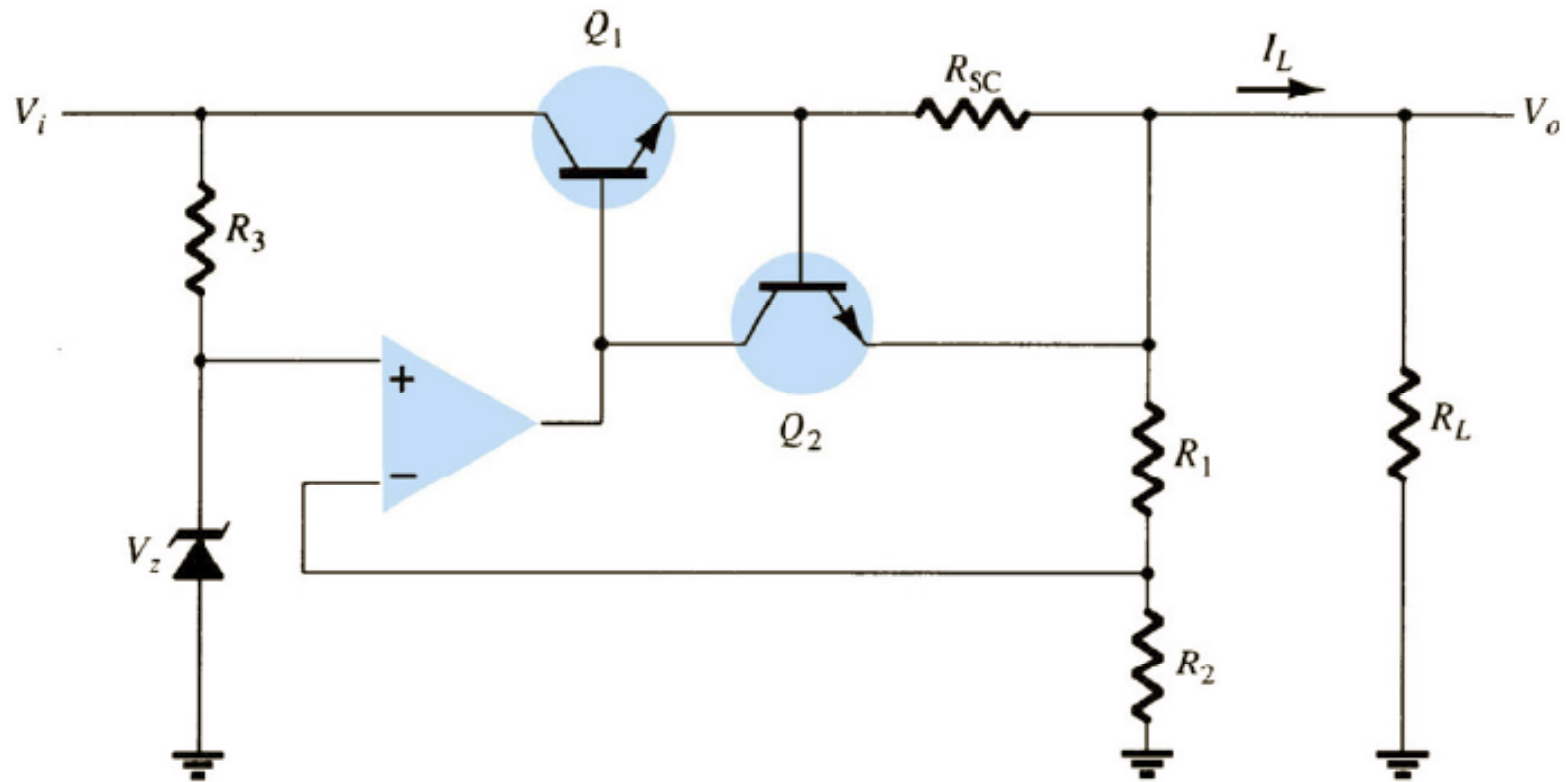

CI's Reguladores de tensão

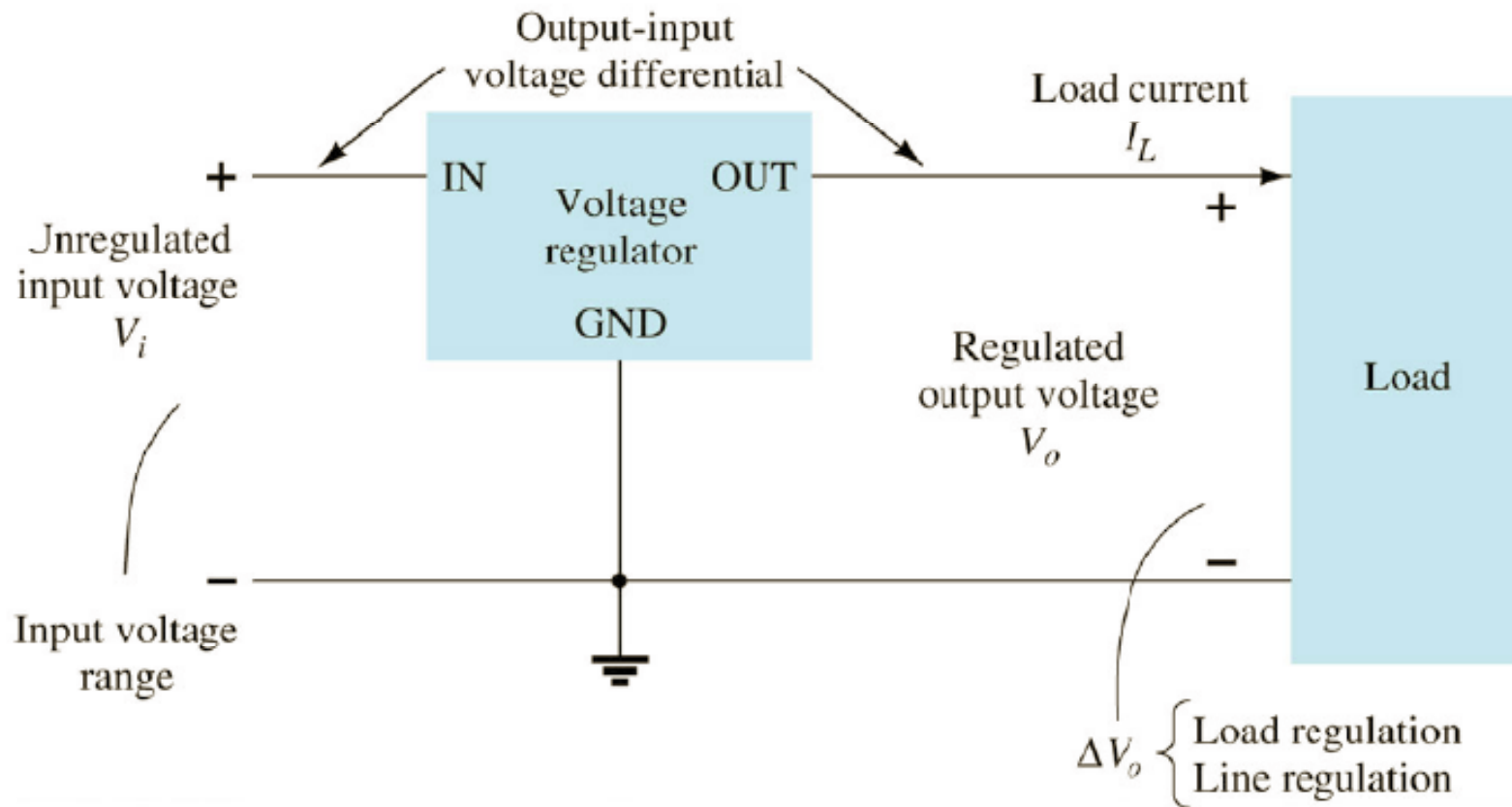

CI's Reguladores de tensão positiva fixa

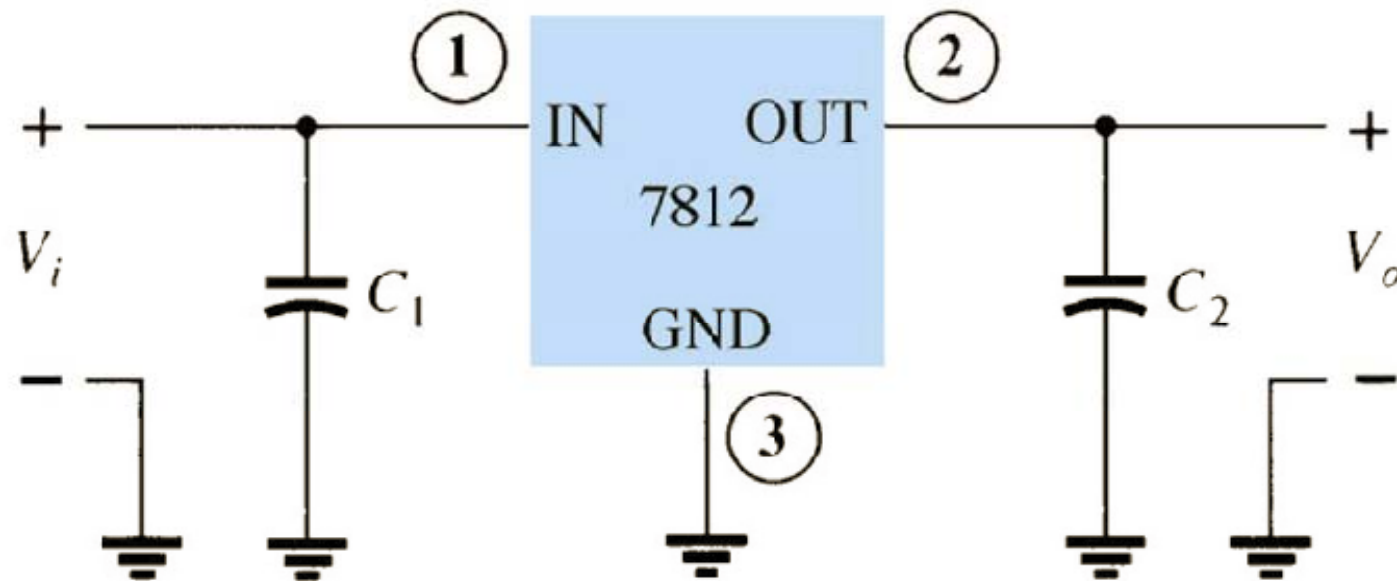

Código do CI	Tensão de saída (V)	V_i mínimo (V)
7805	+5	7,3
7806	+6	8,3
7808	+8	10,5
7810	+10	12,5
7812	+12	14,6
7815	+15	17,7
7818	+18	21,0
7824	+24	27,1

CI's Reguladores de tensão positiva fixa

Princípio de funcionamento:

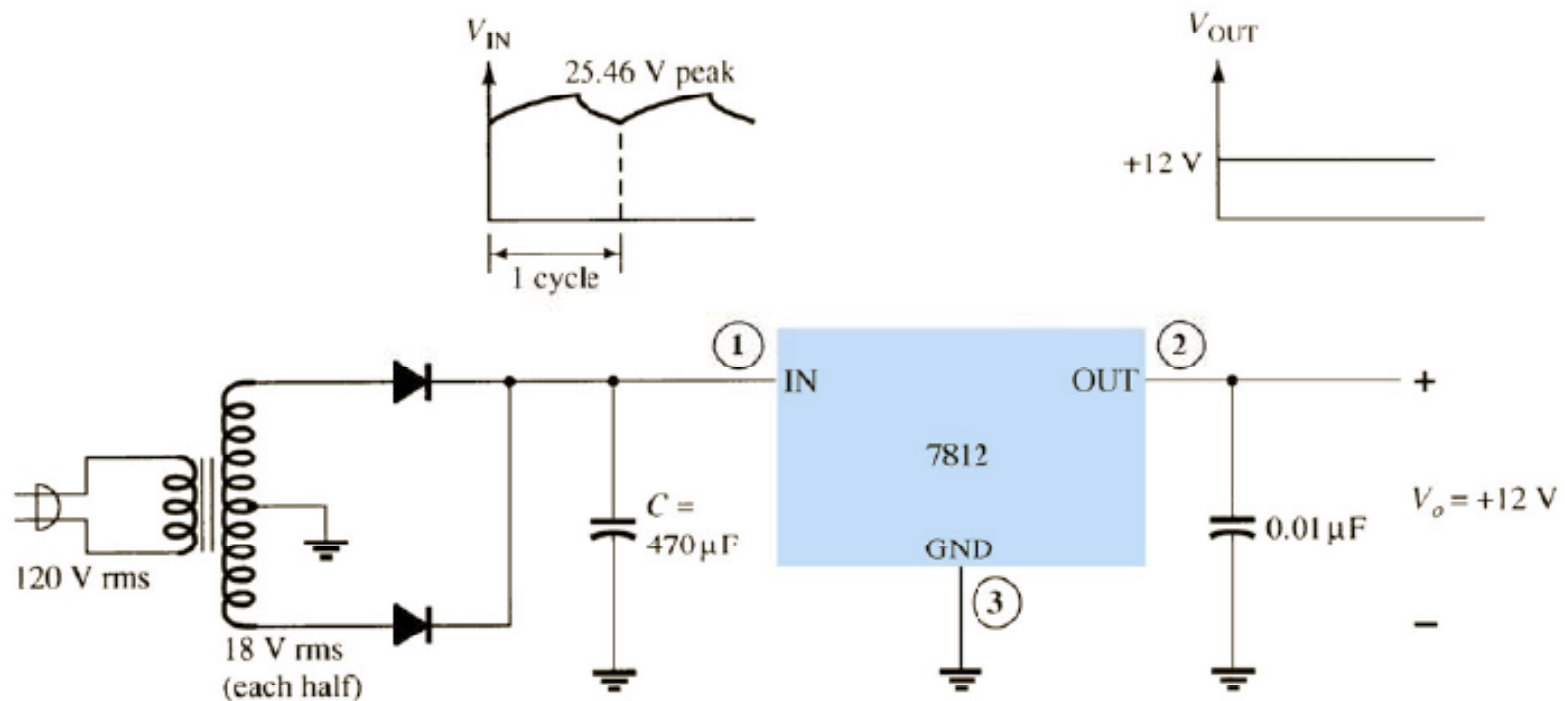

CI's Reguladores de tensão positiva fixa

Exemplo, fonte de +5 V:

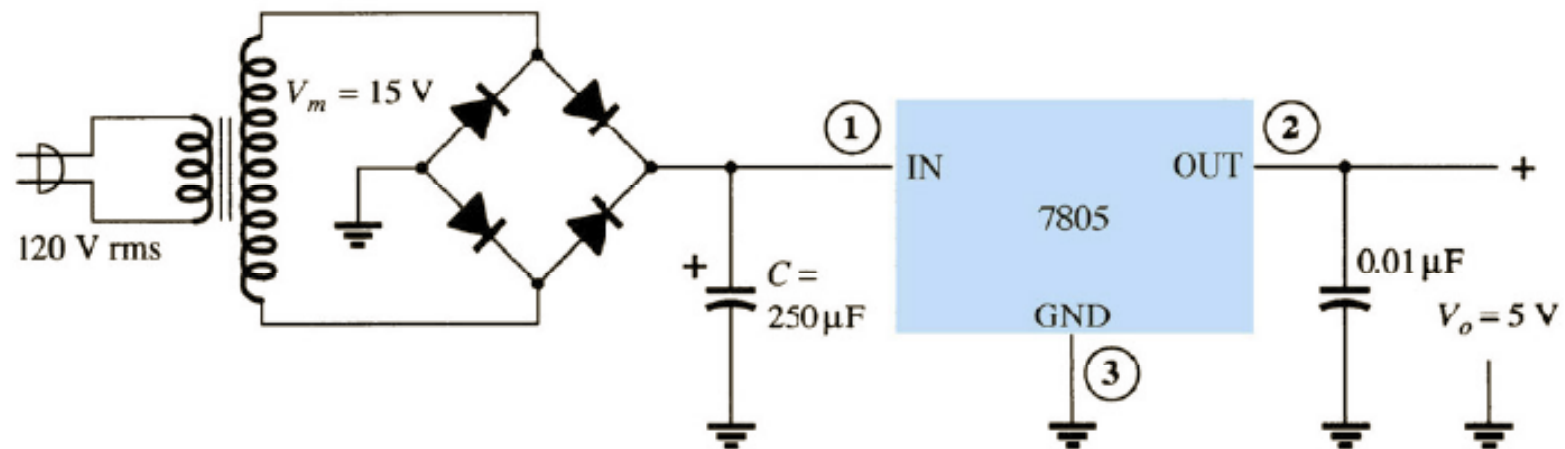

CI's Reguladores de tensão negativa fixa

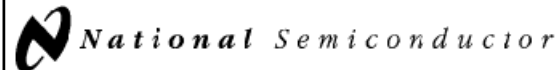

November 1994

LM79XX Series 3-Terminal Negative Regulators

General Description

The LM79XX series of 3-terminal regulators is available with fixed output voltages of $-5V$, $-8V$, $-12V$, and $-15V$. These devices need only one external component—a compensation capacitor at the output. The LM79XX series is packaged in the TO-220 power package and is capable of supplying 1.5A of output current.

These regulators employ internal current limiting safe area protection and thermal shutdown for protection against virtually all overload conditions.

Low ground pin current of the LM79XX series allows output voltage to be easily boosted above the preset value with a resistor divider. The low quiescent current drain of

these devices with a specified maximum change with line and load ensures good regulation in the voltage boosted mode.

For applications requiring other voltages, see LM137 data sheet.

Features

- Thermal, short circuit and safe area protection
- High ripple rejection
- 1.5A output current
- 4% tolerance on preset output voltage

Connection Diagrams

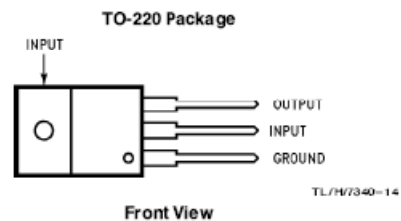

Typical Applications

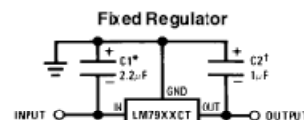

*Required if regulator is separated from filter capacitor more than 3". For value given, capacitor must be tantalum, 25 μF aluminum electrolytic may be substituted.

†Required for stability. For value given, capacitor must be tantalum, 25 μF aluminum electrolytic may be substituted. Values given may be increased without limit.

For output capacitance in excess of 100 μF , a diode from input to output (1N4001, etc.) will protect regulator from momentary input shorts.

Código do CI	Tensão de saída (V)	V _i mínimo (V)
7905	-5	-7,3
7906	-6	-8,4
7908	-8	-10,5
7909	-9	-11,5
7912	-12	-14,6
7915	-15	-17,7
7918	-18	-20,8
7924	-24	-27,1

Especificações de um regulador



Nominal output voltage	Regulator
5 V	7805
6 V	7806
8 V	7808
10 V	7810
12 V	7812
15 V	7815
18 V	7818
24 V	7824

Absolute maximum ratings:

Input voltage 40 V
 Continuous total dissipation 2 W
 Operating free-air temperature range -65 to 150°C

µA 7812C electrical characteristics:

Parameter	Min.	Typ.	Max.	Units
Output voltage	11.5	12	12.5	V
Input regulation		3	120	mV
Ripple rejection	55	71		dB
Output regulation		4	100	mV
Output resistance		0.018		Ω
Dropout voltage		2.0		V
Short-circuit output current		350		mA
Peak output current		2.2		A

May 2008

LM78XX/LM78XXA 3-Terminal 1A Positive Voltage Regulator

Features

- Output Current up to 1A
- Output voltages of 5, 6, 8, 9, 10, 12, 15, 18, 24
- Thermal Overload Protection
- Short Circuit Protection
- Output Transistor Safe Operating Area Protection

General Description

The LM78XX series of three terminal positive regulators are available in the TO-220 package and with several fixed output voltages, making them useful in a wide range of applications. Each type employs internal current limiting, thermal shut down and safe operating area protection, making it essentially indestructible. If adequate heat sinking is provided they can deliver over 1A output current. Although designed primarily as fixed voltage regulators, these devices can be used with external components to obtain adjustable voltages and currents.

Ordering Information

Product Number	Output Voltage Tolerance	Package	Operating Temperature
LM7805CT	±4%	TO-220	-40°C to +125°C
LM7806CT			
LM7808CT			
LM7809CT			
LM7810CT			
LM7812CT			
LM7815CT			
LM7818CT			
LM7824CT			
LM7805ACT			
LM7806ACT			
LM7808ACT			
LM7809ACT			
LM7810ACT			
LM7812ACT			
LM7815ACT			
LM7818ACT			
LM7824ACT			

Reguladores de tensão ajustável

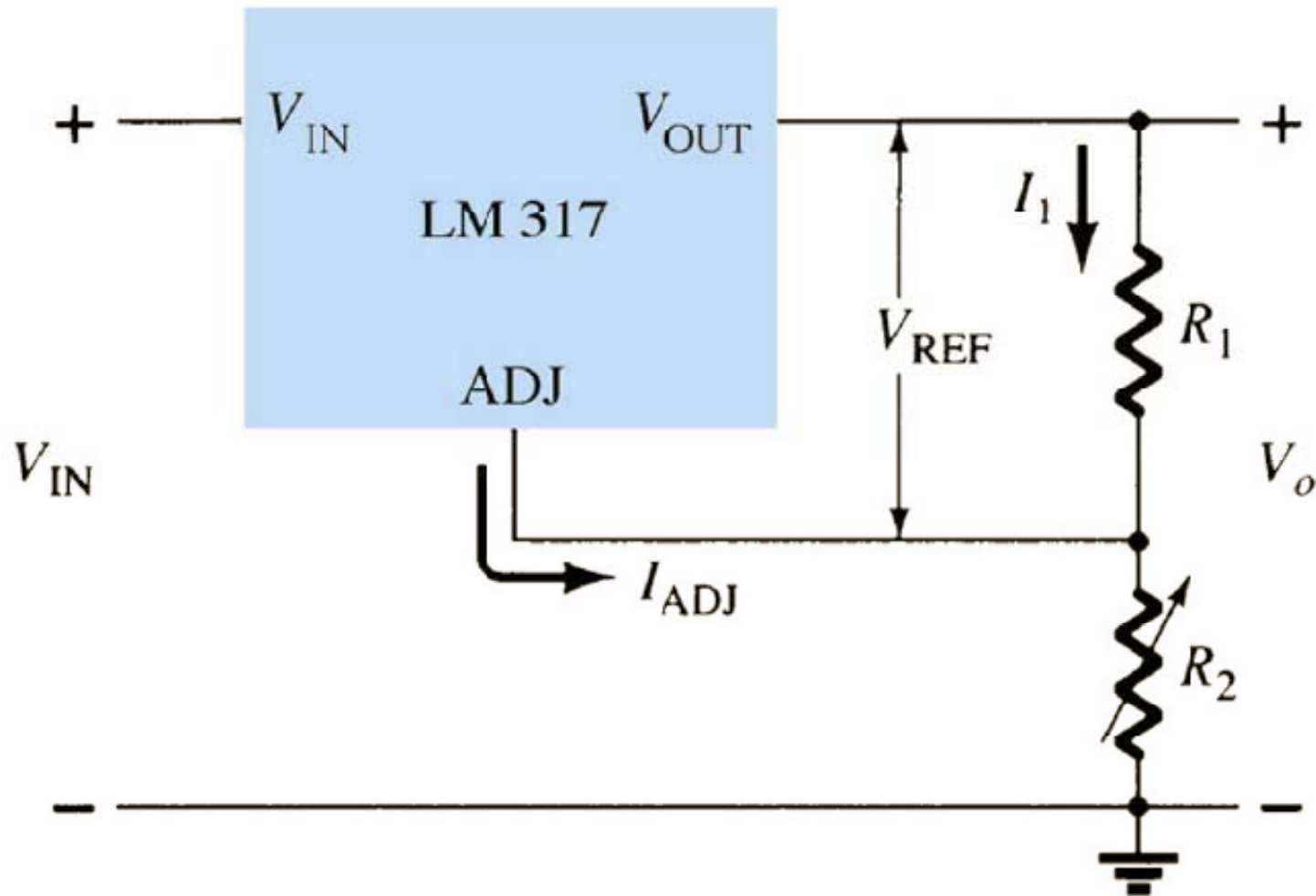

Reguladores de tensão ajustável

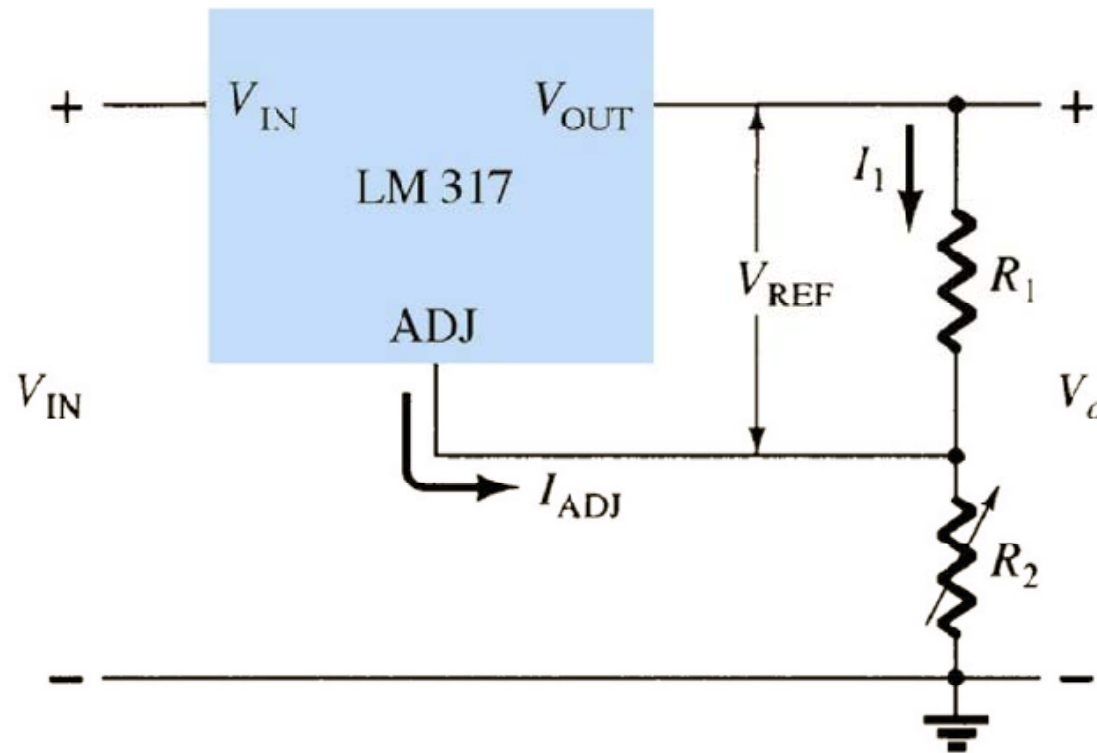

$$V_{ref} = 1,25V$$

$$I_{ADJ} = 50 \text{ ou } 100 \mu A$$

$$V_o = V_{ref} \left(1 + \frac{R_2}{R_1} \right) + I_{ADJ} \cdot R_2$$

Reguladores de tensão ajustável

Exemplo:

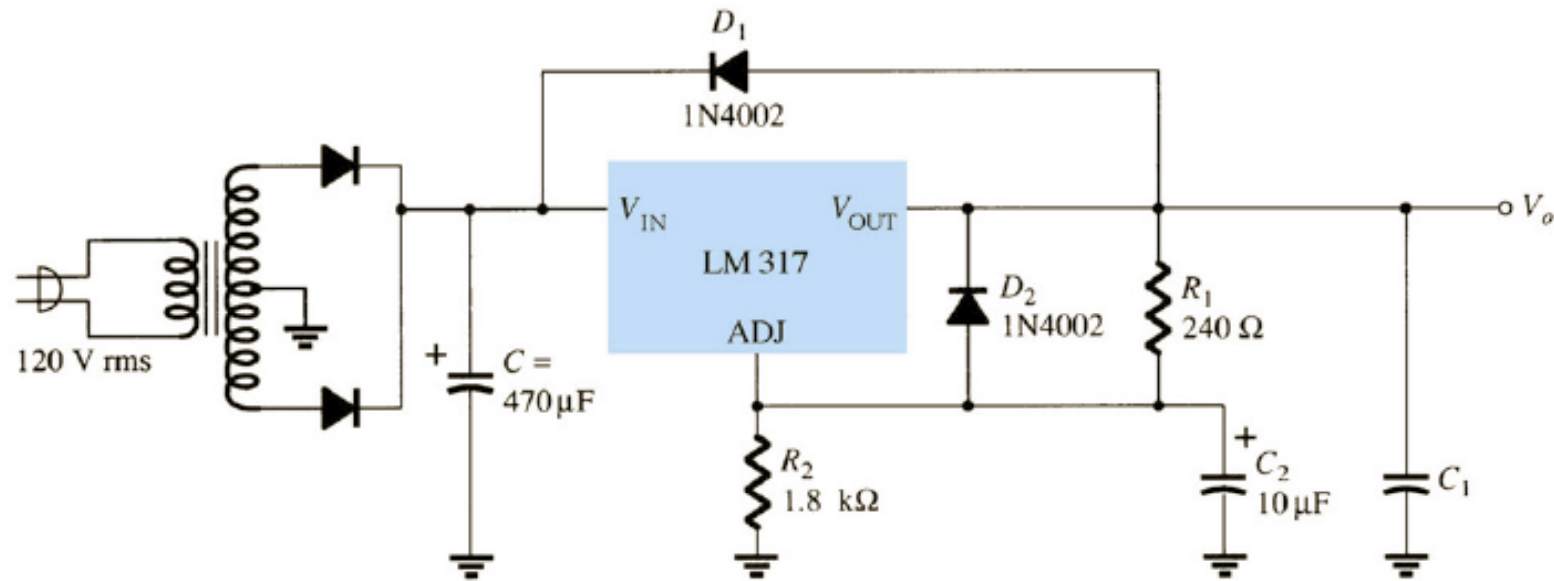

Determinar V_o :

$$V_o = V_{ref} \left(1 + \frac{R_2}{R_1} \right) + I_{ADJ} \cdot R_2 = 1,25 \left(1 + \frac{1,8k}{240} \right) + 100 \mu \cdot 1,8k \cong 10,8V$$

Na próxima aula

Seqüência de conteúdos:

1. Laboratórios de reguladores de tensão.

