

Centro Federal de Educação Tecnológica de Santa Catarina
Departamento Acadêmico de Eletrônica
Retificadores



Lei de Ampère, Fluxo Magnético
Circuitos Magnéticos, Entreferrros,
Força Magnética e Aplicações

Prof. Clóvis Antônio Petry.

Florianópolis, setembro de 2008.

Bibliografia para esta aula

Capítulo 11: Circuitos magnéticos

1. Lei de Ampère;
2. Fluxo;
3. Circuitos magnéticos;
4. Entrefeirros;
5. Força magnética;
6. Aplicações.

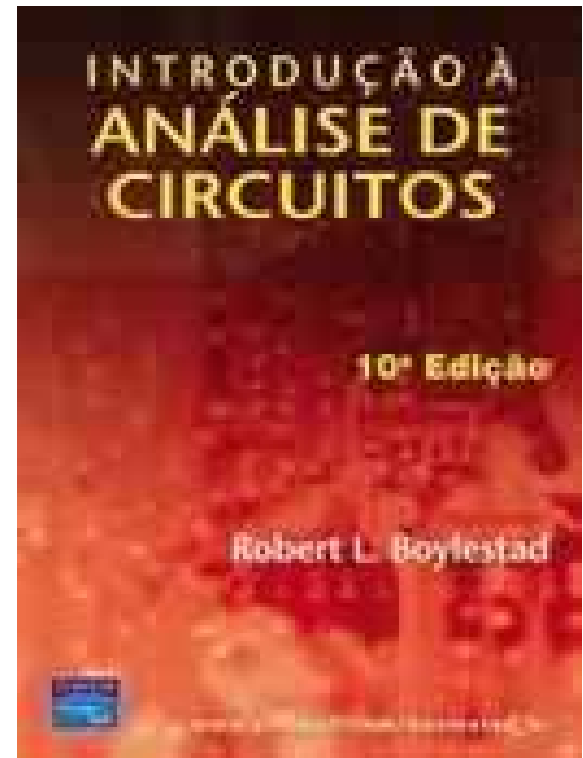

Lei circuital de Ampère

O somatório das forças em um caminho fechado é nulo:

$$\sum V = 0$$

Lei de Kirchhoff das tensões



Lei circuital de Ampère

$$\sum \mathcal{F} = 0$$

Ação de	Circuitos elétricos	Circuitos magnéticos
Causa	E	\mathcal{F}
Efeito	I	Φ
Oposição	R	\mathcal{R}

Lei circuital de Ampère

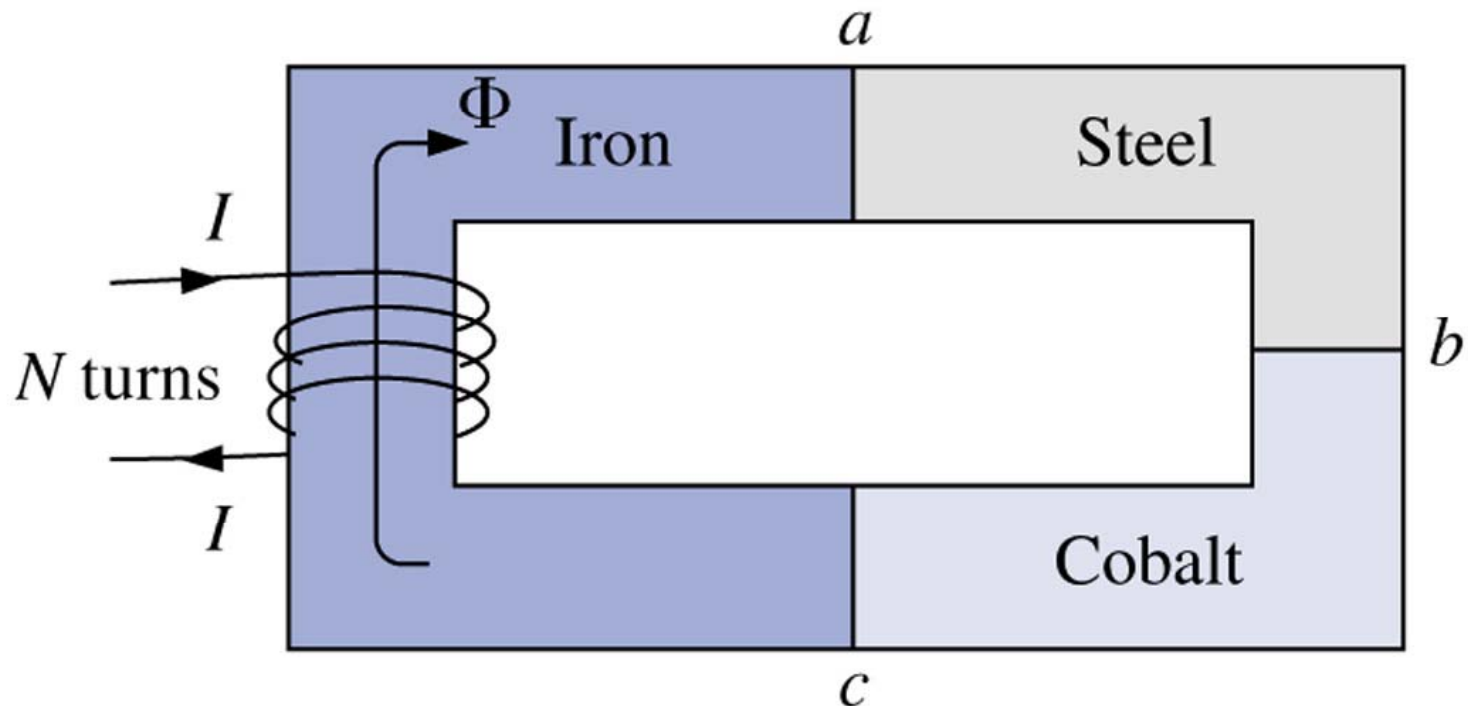

$$\sum \mathfrak{F} = 0 \quad N \cdot I - H_{ab} \cdot l_{ab} - H_{bc} \cdot l_{bc} - H_{ca} \cdot l_{ca} = 0$$

$$N \cdot I = H_{ab} \cdot l_{ab} + H_{bc} \cdot l_{bc} + H_{ca} \cdot l_{ca}$$

Fmm aplicada

Queda de fmm

Fluxo Φ

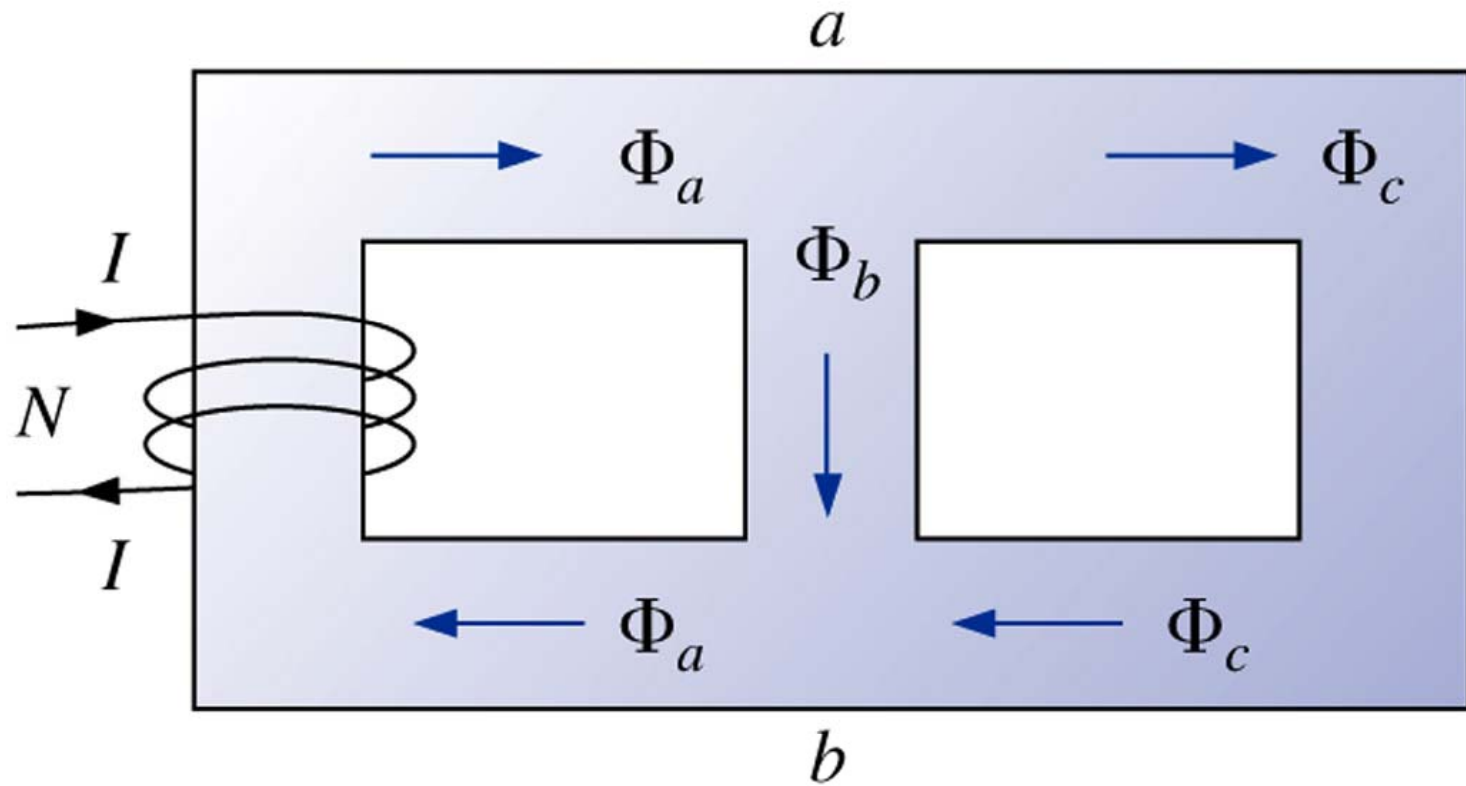

$$\Phi_a = \Phi_b + \Phi_c \quad (\text{na junção } a)$$

$$\Phi_b + \Phi_c = \Phi_a \quad (\text{na junção } b)$$

Circuitos magnéticos

Exemplo 11.4: Determinar a corrente I necessária para estabelecer o fluxo Φ :

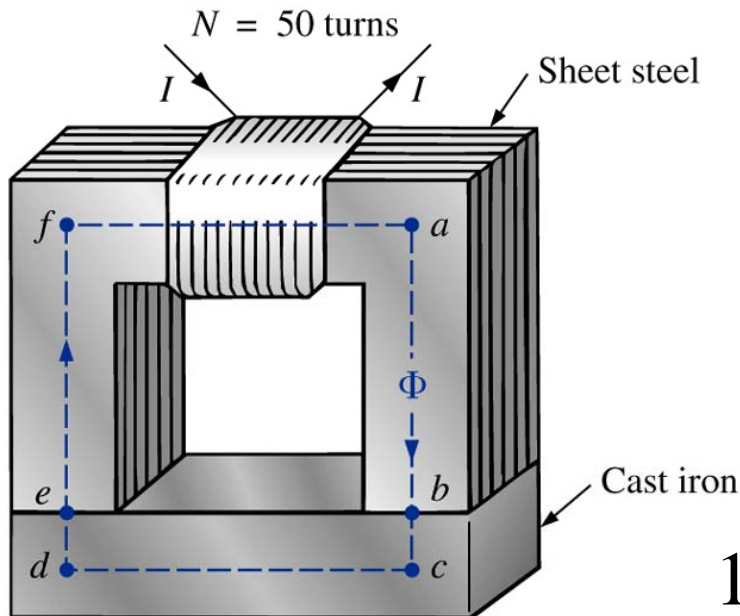

$$l_{efab} = 4 + 4 + 4 = 12 \text{ pol.}$$

$$l_{bcde} = 0,5 + 4 + 0,5 = 5 \text{ pol.}$$

$$12 \text{ pol.} = 304,8 \cdot 10^{-3} \text{ m}$$

$$5 \text{ pol.} = 127 \cdot 10^{-3} \text{ m}$$

$$1 \text{ pol.}^2 = 6,452 \cdot 10^{-4} \text{ m}$$

$$\begin{aligned} l_{ab} &= l_{cd} = l_{ef} = l_{fa} = 4 \text{ in.} \\ l_{bc} &= l_{de} = 0,5 \text{ in.} \\ \text{Area (throughout)} &= 1 \text{ in.}^2 \\ \Phi &= 3,5 \times 10^{-4} \text{ Wb} \end{aligned}$$

$$B = \frac{\Phi}{A} = \frac{3,5 \cdot 10^{-4} \text{ Wb}}{6,452 \cdot 10^{-4} \text{ m}^2} = 0,542 \text{ T}$$



Circuitos magnéticos

Exemplo 11.4: Determinar a corrente I necessária para estabelecer o fluxo Φ :

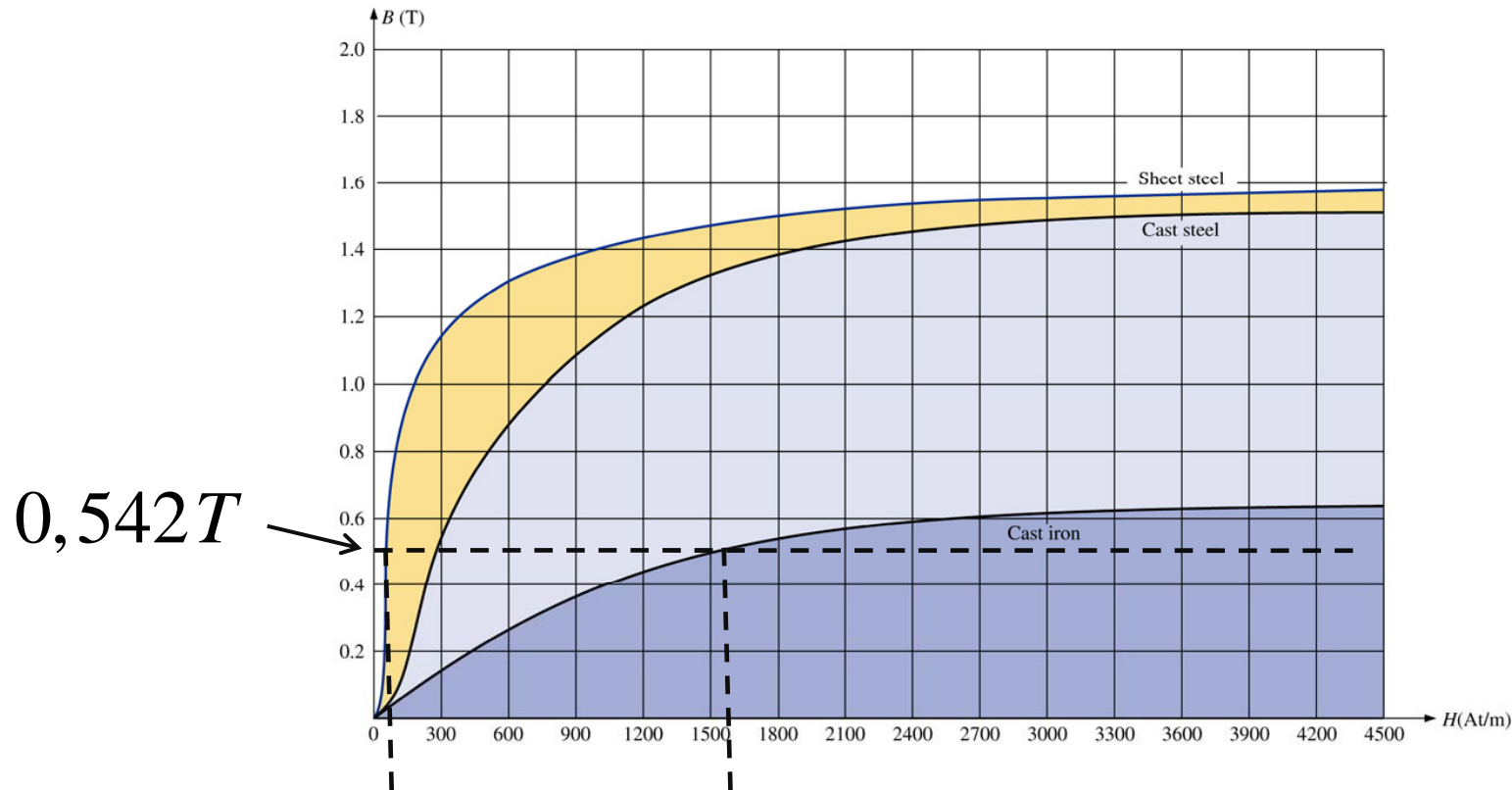

$0,542T$

$$H_{\text{aço}} \approx 70 \text{ A/m}$$

$$H_{\text{ferro}} \approx 1600 \text{ A/m}$$



Circuitos magnéticos

Exemplo 11.4: Determinar a corrente I necessária para estabelecer o fluxo Φ :

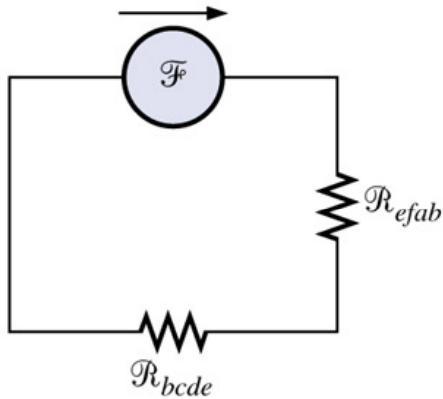

(a)

$$H_{efab} \cdot l_{efab} = 70 \cdot 304,8 \cdot 10^{-3} = 21,34 \text{ A}$$

$$H_{bcde} \cdot l_{bcde} = 1600 \cdot 127 \cdot 10^{-3} = 203,2 \text{ A}$$

$$N \cdot I = H_{efab} \cdot l_{efab} + H_{bcde} \cdot l_{bcde} = 224,54 \text{ A}$$

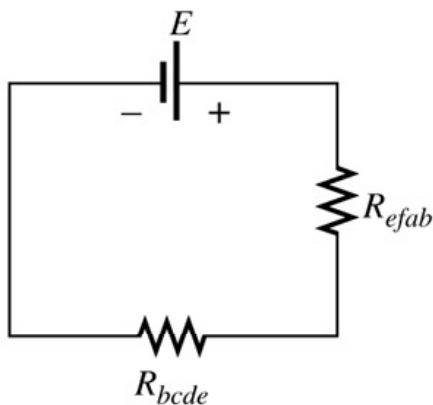

(b)

$$I = \frac{224,54}{N} = \frac{224,54}{50} = 4,49 \text{ A}$$

Entreferros

Espaço sem núcleo nos circuitos magnéticos:

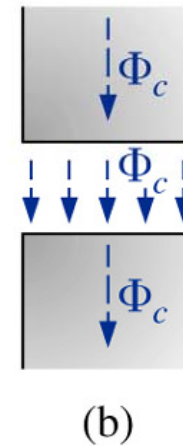
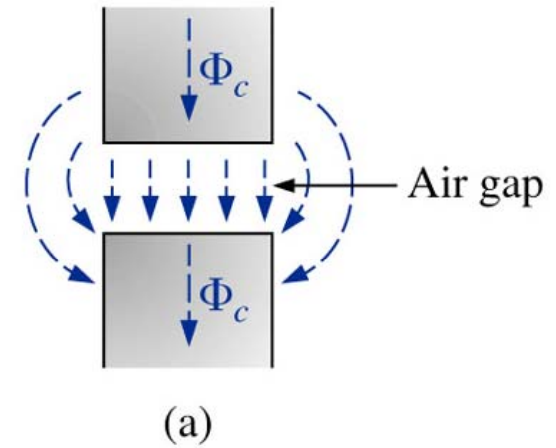
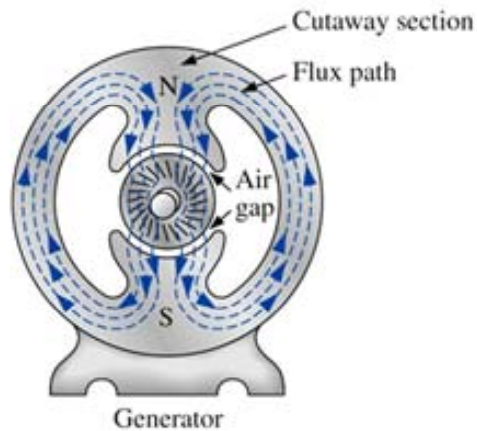
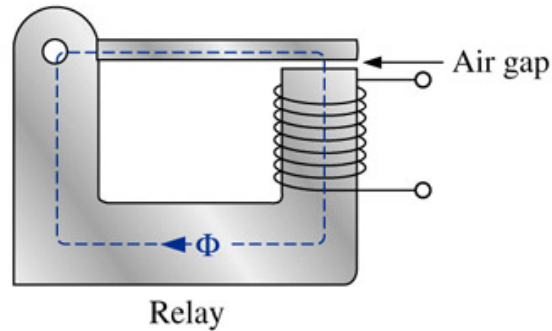
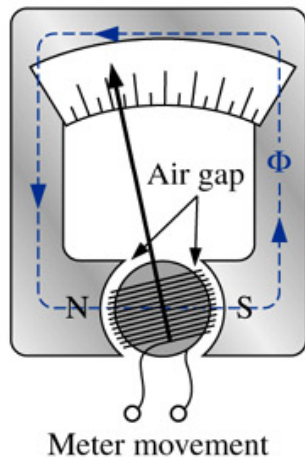

Entreferros

Exemplo 11.6: Determinar a corrente I necessária para estabelecer o fluxo Φ :

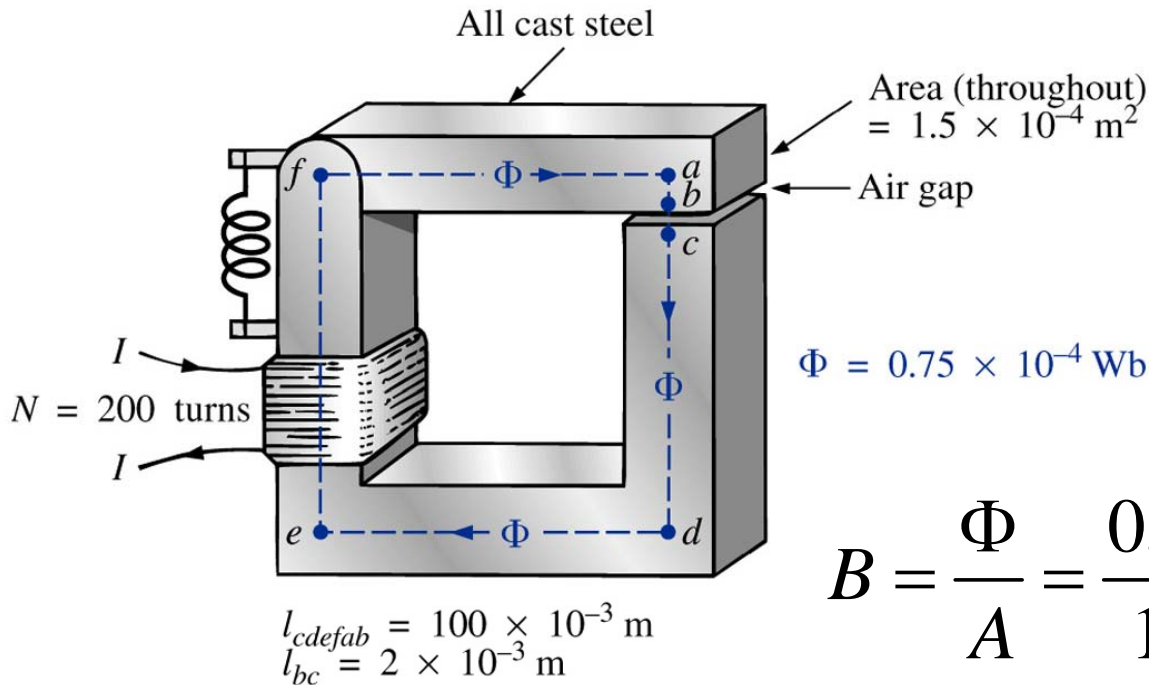

$$B = \frac{\Phi}{A} = \frac{0,75 \cdot 10^{-4} \text{ Wb}}{1,5 \cdot 10^{-4} \text{ m}^2} = 0,5 \text{ T}$$



Entreferos

Exemplo 11.6: Determinar a corrente I necessária para estabelecer o fluxo Φ :

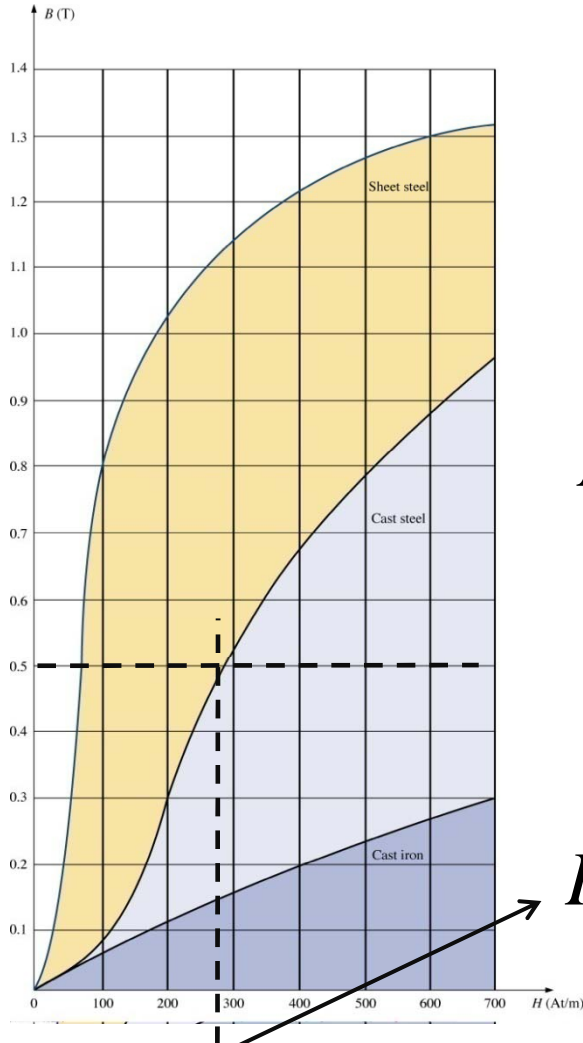

$$H_g = \frac{B_g}{\mu_o} = \frac{B_g}{4\pi \cdot 10^{-7}}$$

$$H_g = \frac{0,5}{4\pi \cdot 10^{-7}} = 3,98 \cdot 10^5 A/m$$

$$H_{aço} \cong 280 A/m$$



Entreferros

Exemplo 11.6: Determinar a corrente I necessária para estabelecer o fluxo Φ :

$$H_{nucleo} \cdot l_{nucleo} = 280 \cdot 100 \cdot 10^{-3} = 28 A$$

$$H_g \cdot l_g = 3,98 \cdot 10^5 \cdot 2 \cdot 10^{-3} = 796 A$$

$$N \cdot I = H_{nucleo} \cdot l_{nucleo} + H_g \cdot l_g = 824 A$$

$$I = \frac{824}{N} = \frac{824}{200} = 4,12 A$$



Entreferros

Exemplo 11.6: Determinar a corrente I necessária para estabelecer o fluxo Φ :

**Para a corrente determinada, determinar
B desconsiderando o entreferro**

$$N \cdot I = H_{nucleo} \cdot l_{nucleo} = 200 \cdot 4,12 = 824 \text{ A}$$

$$H_{nucleo} = \frac{N \cdot I}{l_{nucleo}} = \frac{824}{100 \cdot 10^{-3}} = 8240 \text{ A/m}$$



Entreferos

Exemplo 11.6: Determinar a corrente I necessária para estabelecer o fluxo Φ :

**Para a corrente determinada, determinar
B desconsiderando o entreferro**

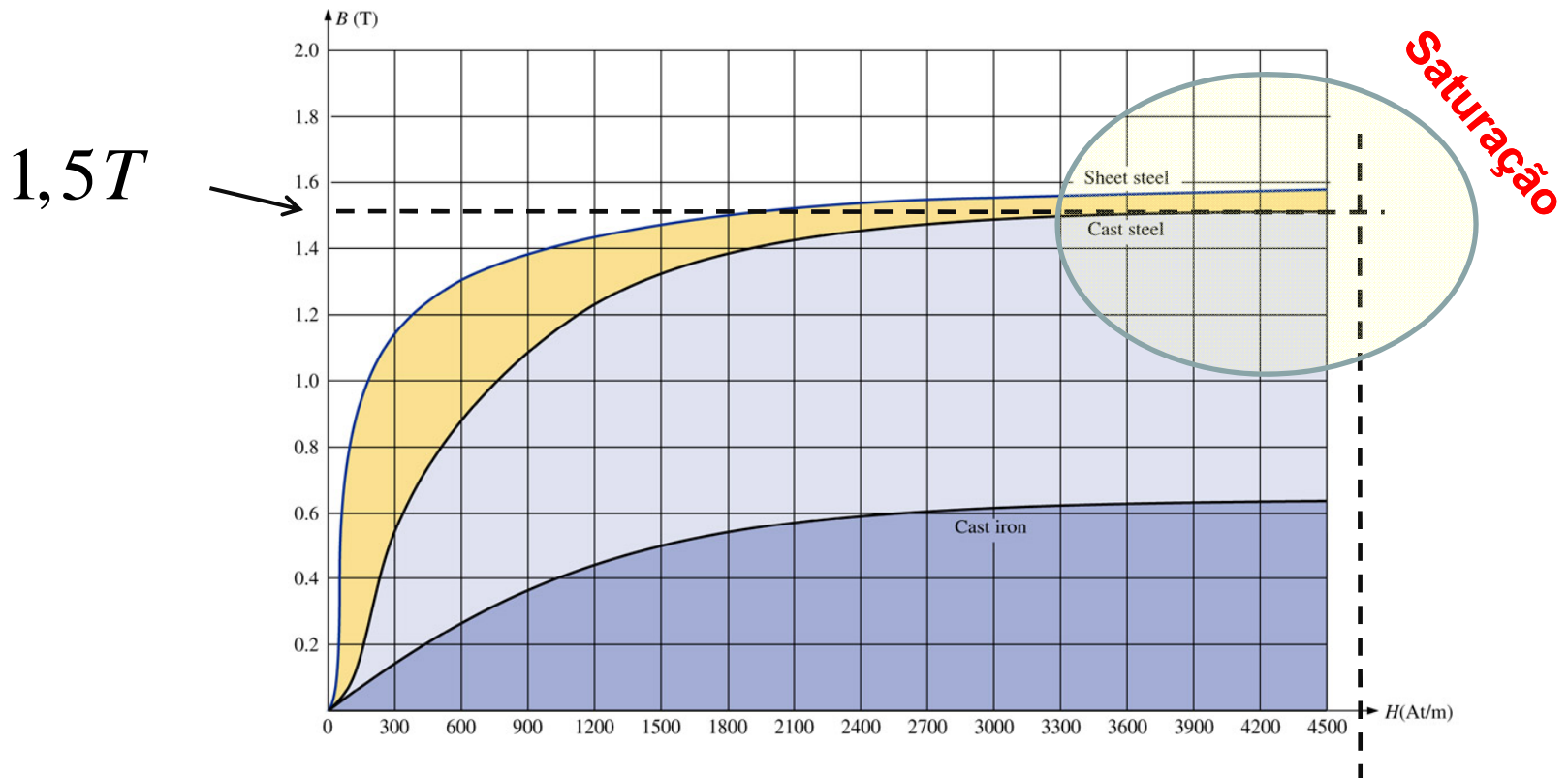

$$H_{ferro} = 8240 \text{ A/m}$$

Força eletromagnética

Força eletromagnética:

- Um condutor percorrido por uma corrente elétrica e imerso em um campo magnético sofre a ação de uma força eletromagnética.

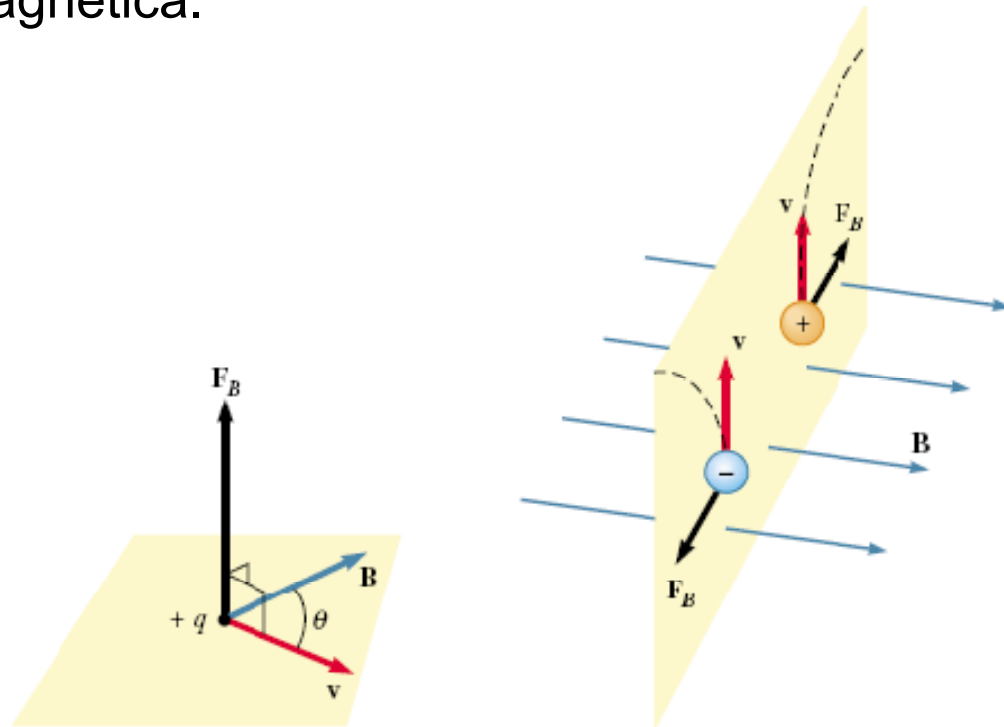

A força é perpendicular aos vetores v e B .

Força eletromagnética

A força pode ocorrer em:

- Um condutor retilíneo;
- Uma partícula;
- Condutores paralelos;
- Em uma espira.

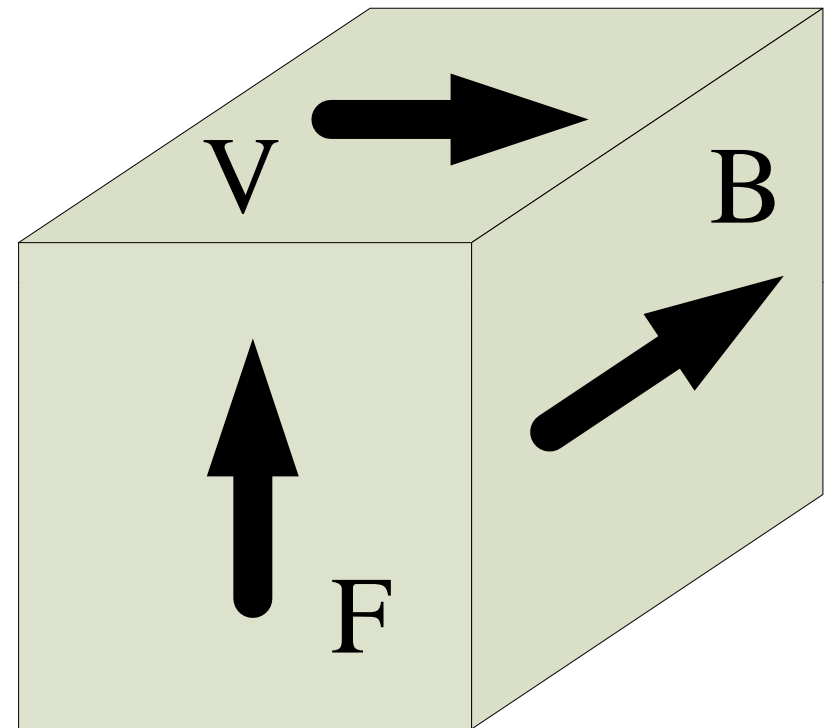
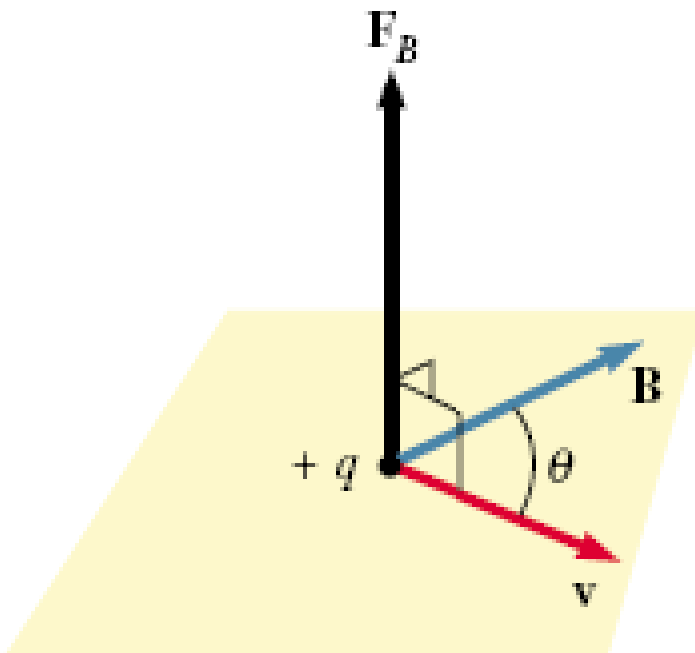

Método da caixa de vetores

Força eletromagnética

Regra da mão esquerda:

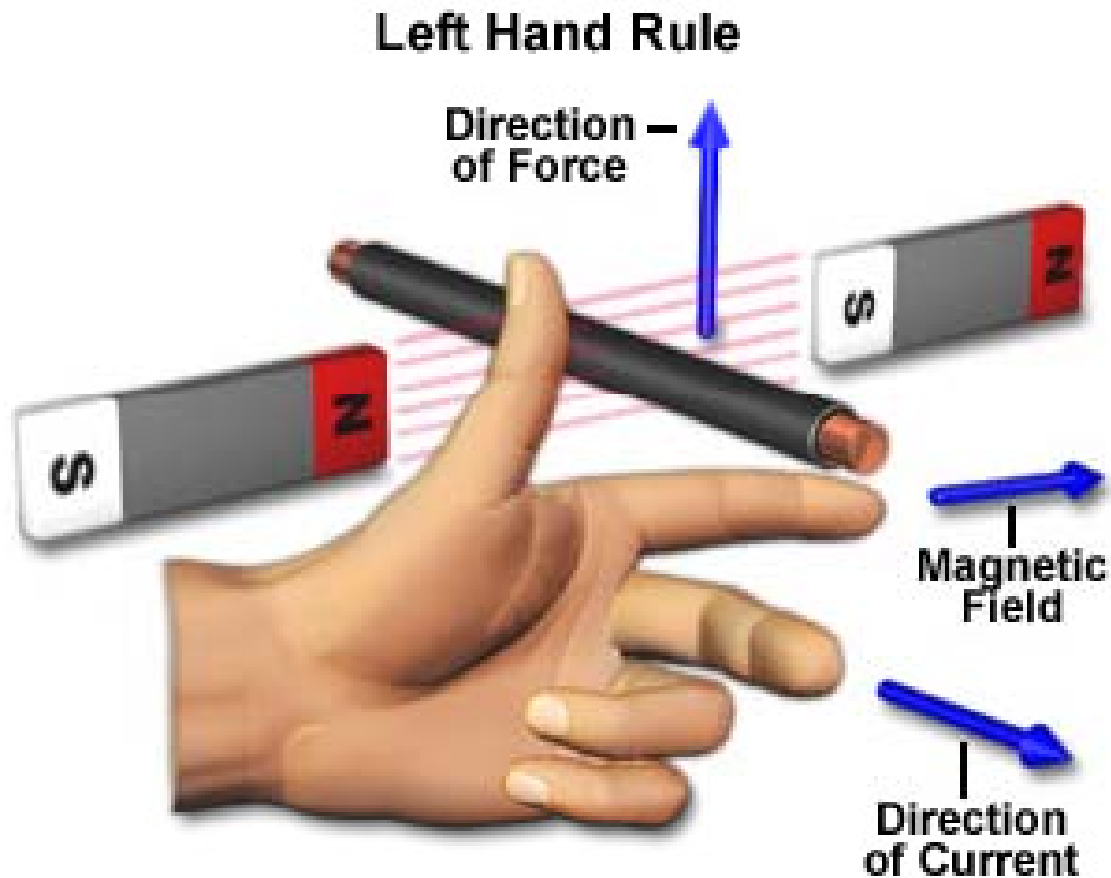

Força eletromagnética

Torque em uma espira:

Applets em java →

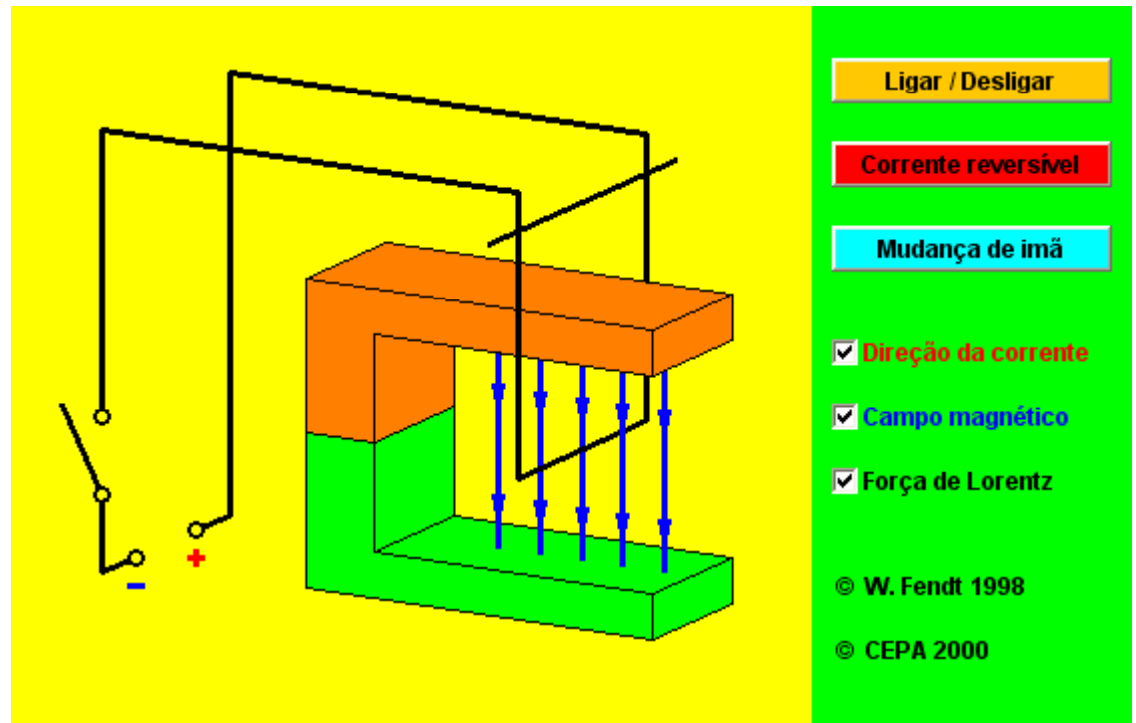

<http://www.walter-fendt.de/ph11br/>

Aplicações - Eletroímã

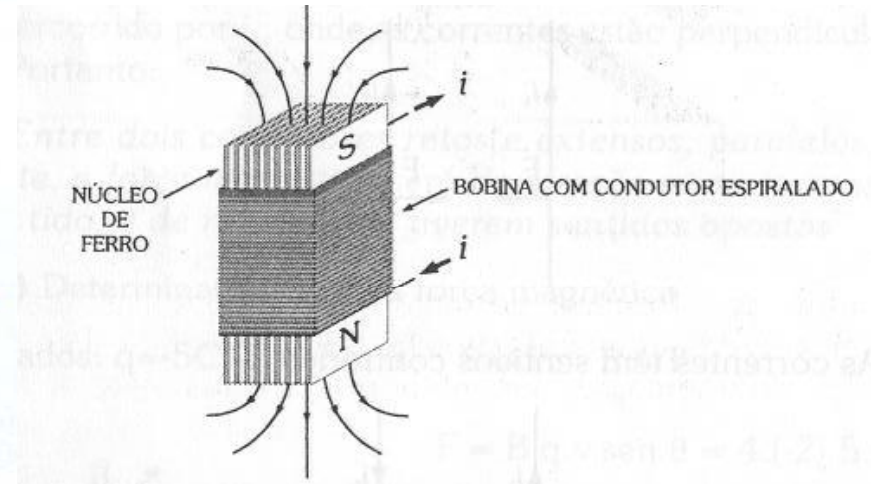
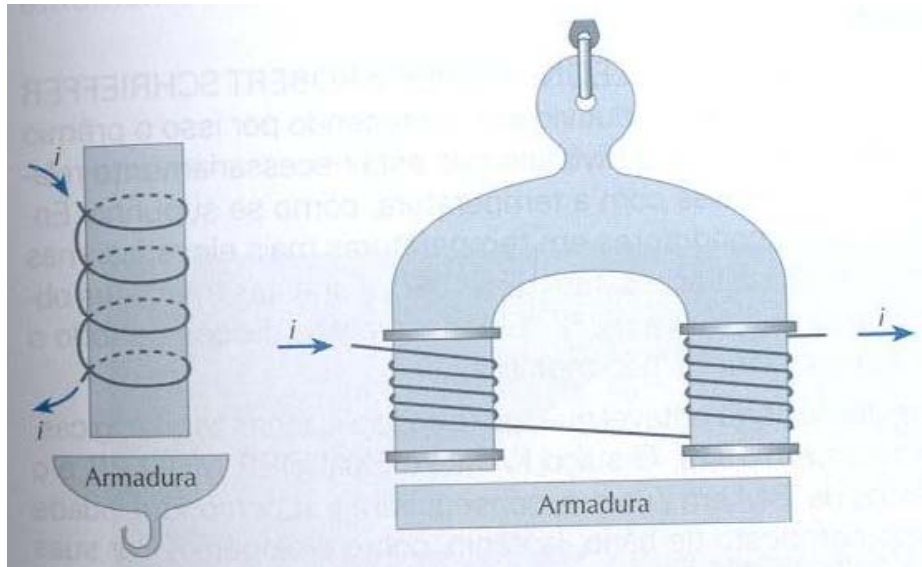

Aplicações - Amperímetro

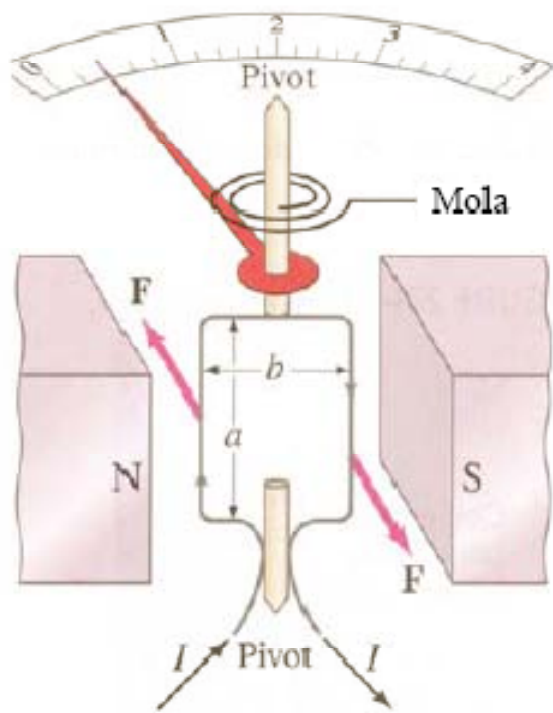

(a)

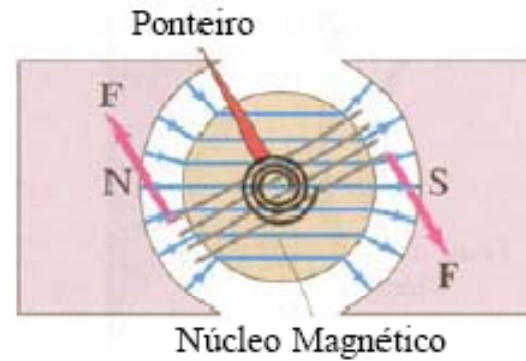

(b)

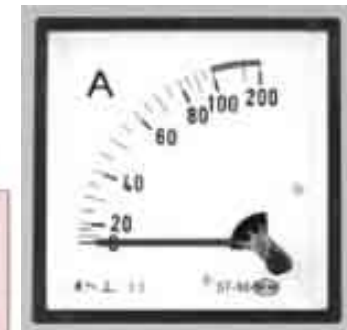

Aplicações – Motor CC

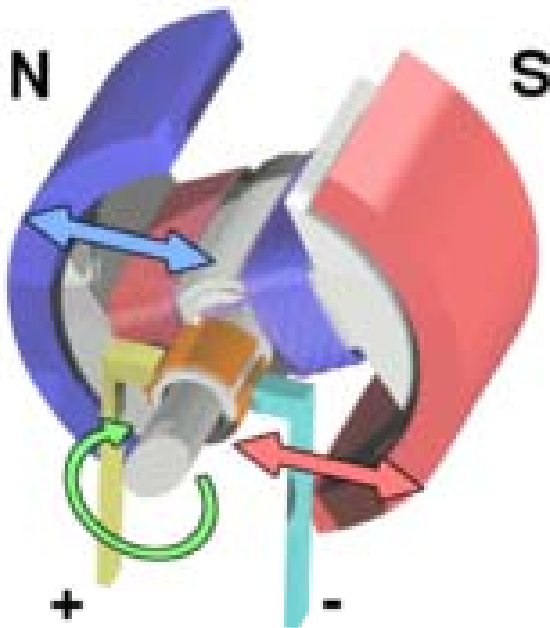

Construção de um motor CC

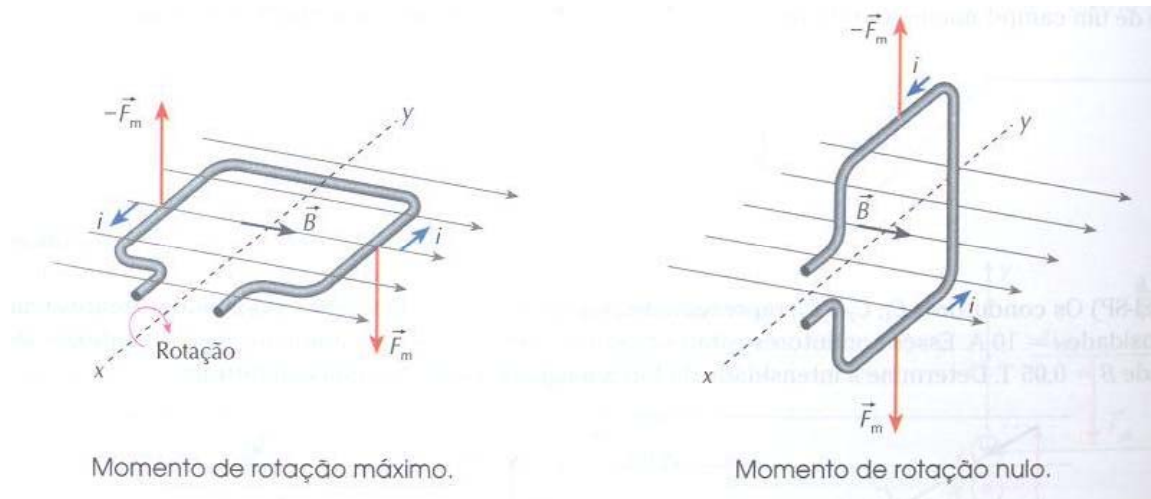

Funcionamento dos motores de CC

Aplicações – Motor CC

Forças num motor de CC

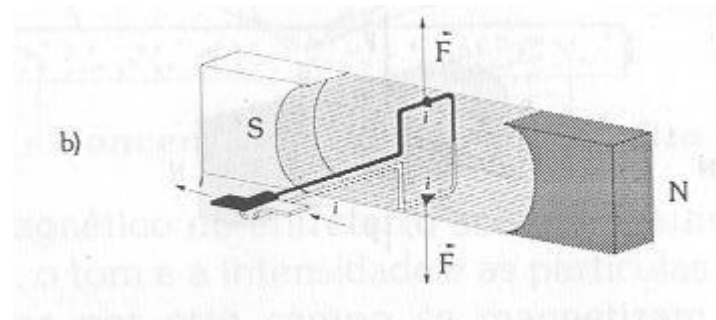
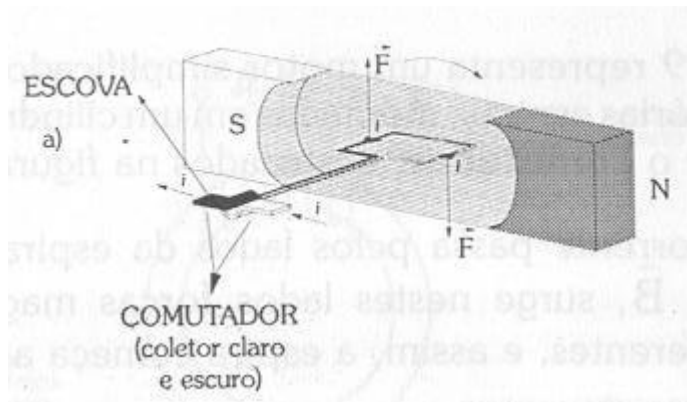
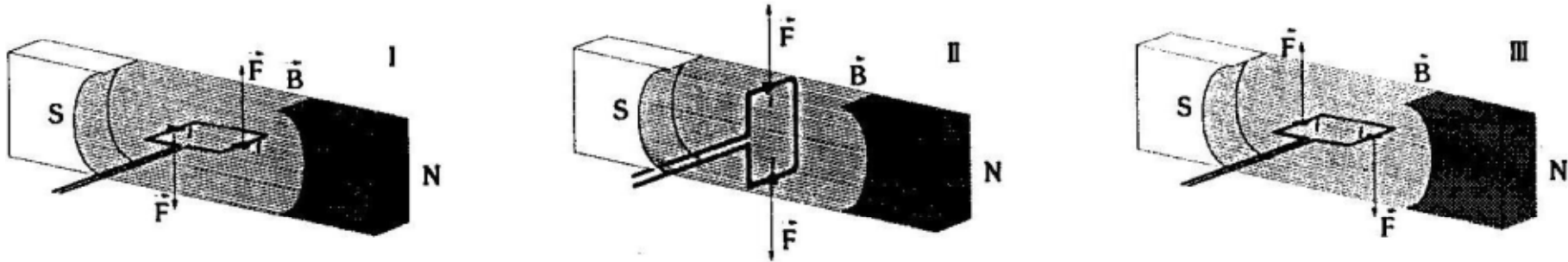

Funcionamento do motor CC

Applets em java →

<http://www.walter-fendt.de/ph11br/>

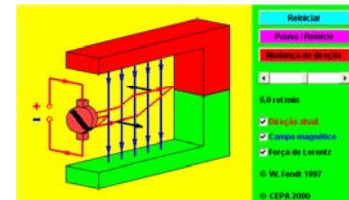

Aplicações - Efeito Hall

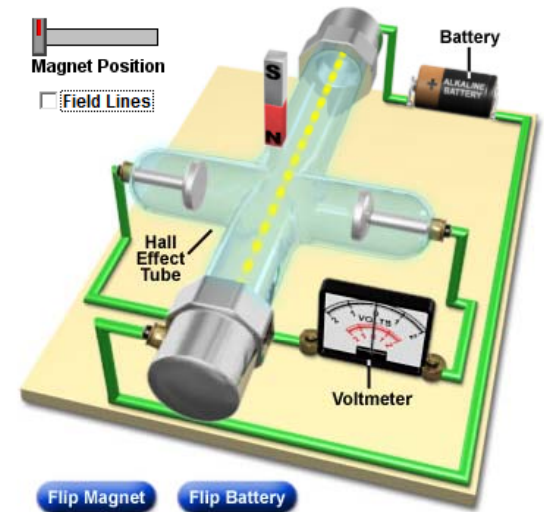
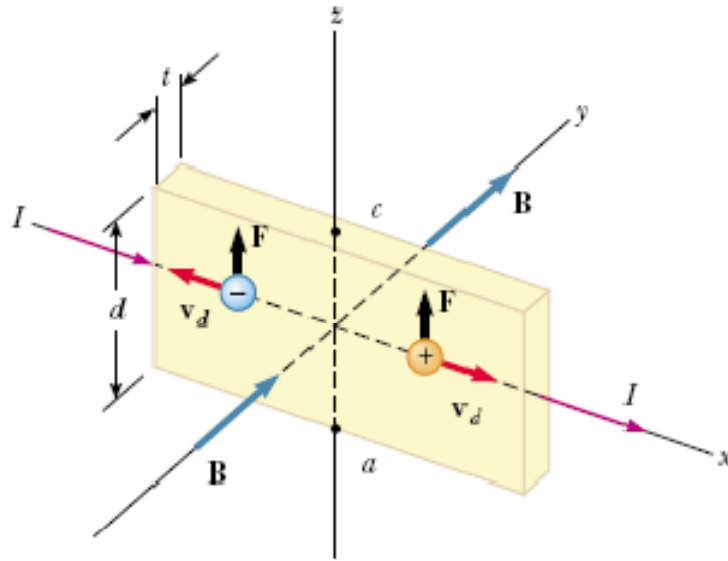

<http://www.magnet.fsu.edu>

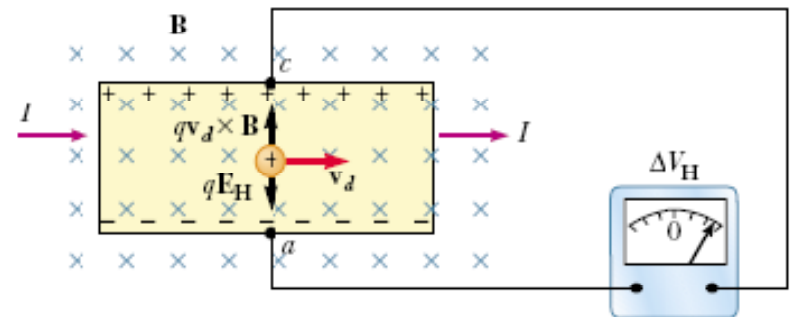
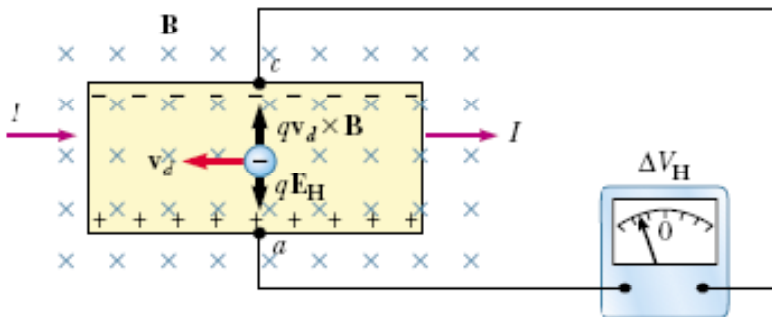

Aplicações – Gravação magnética



Aplicações – Alto-falante

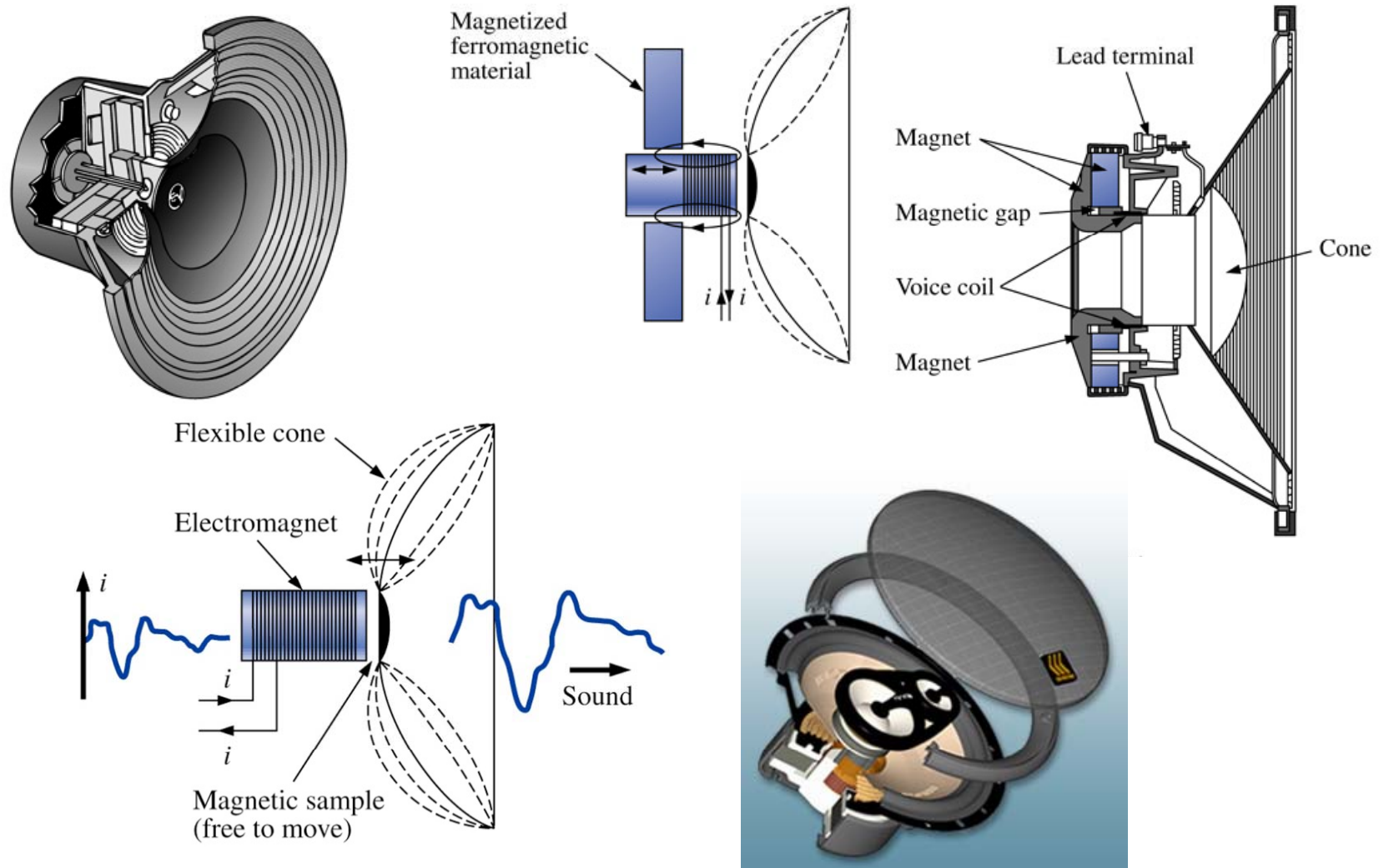

Aplicações – Discos rígidos

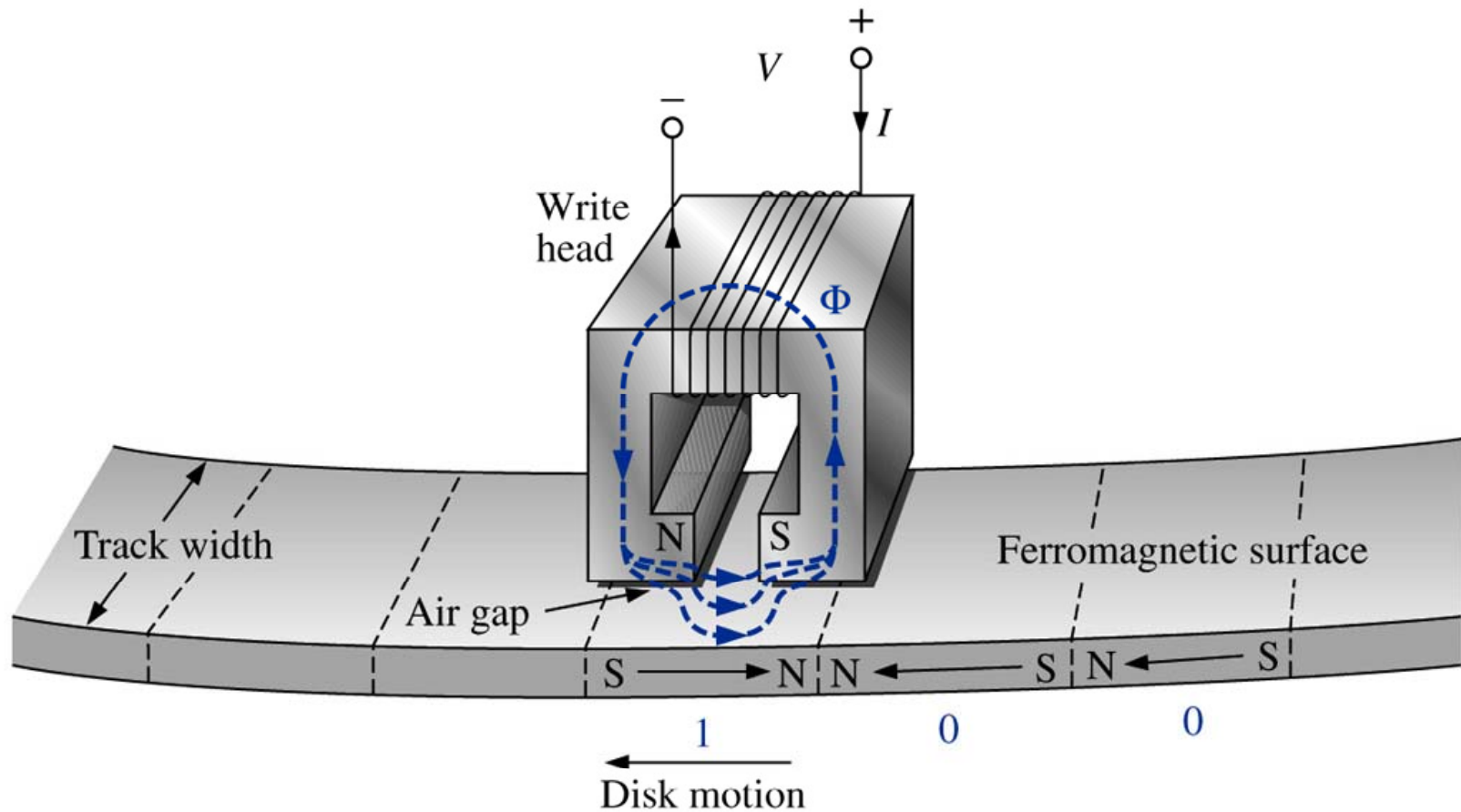

Aplicações – Discos rígidos

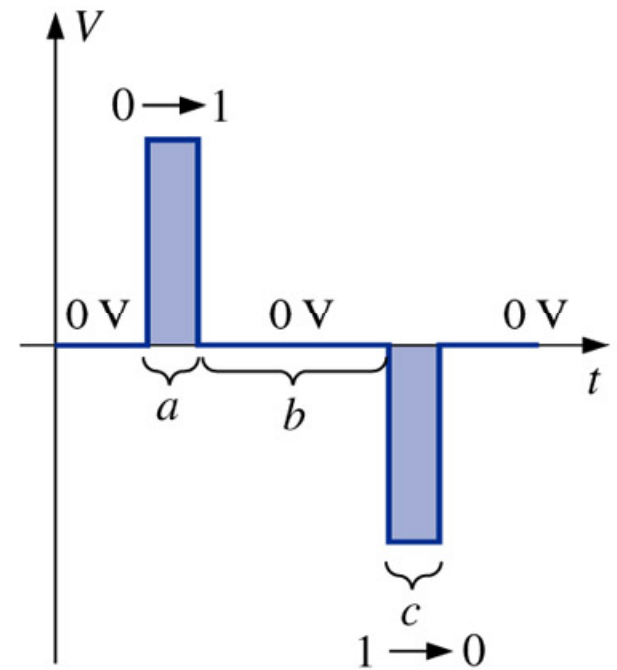
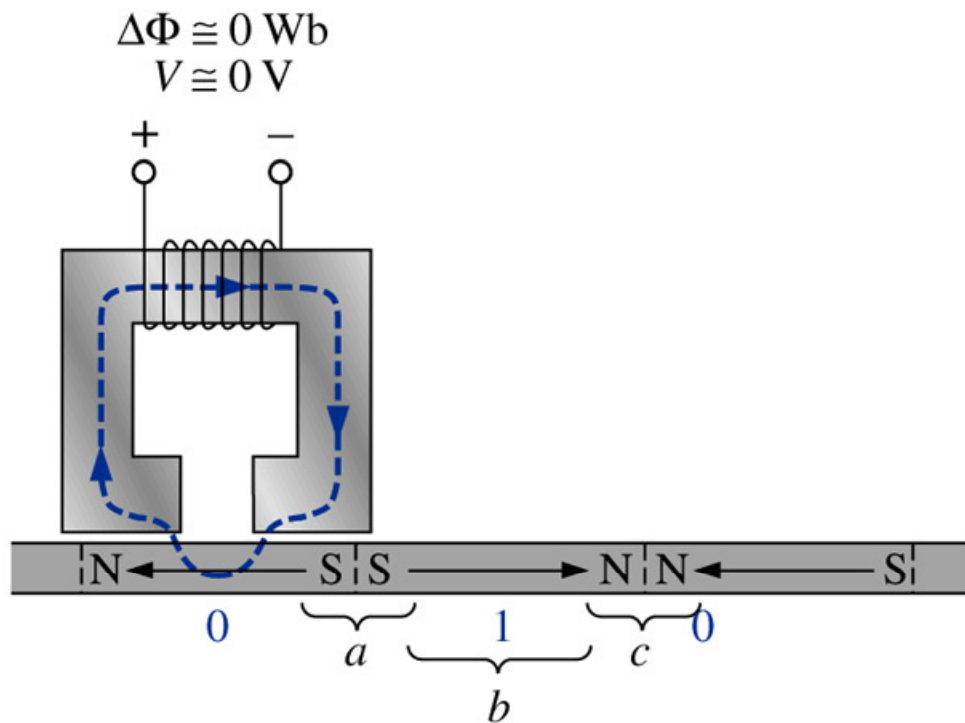

Aplicações – Discos rígidos



<http://www.guiadohardware.net/>

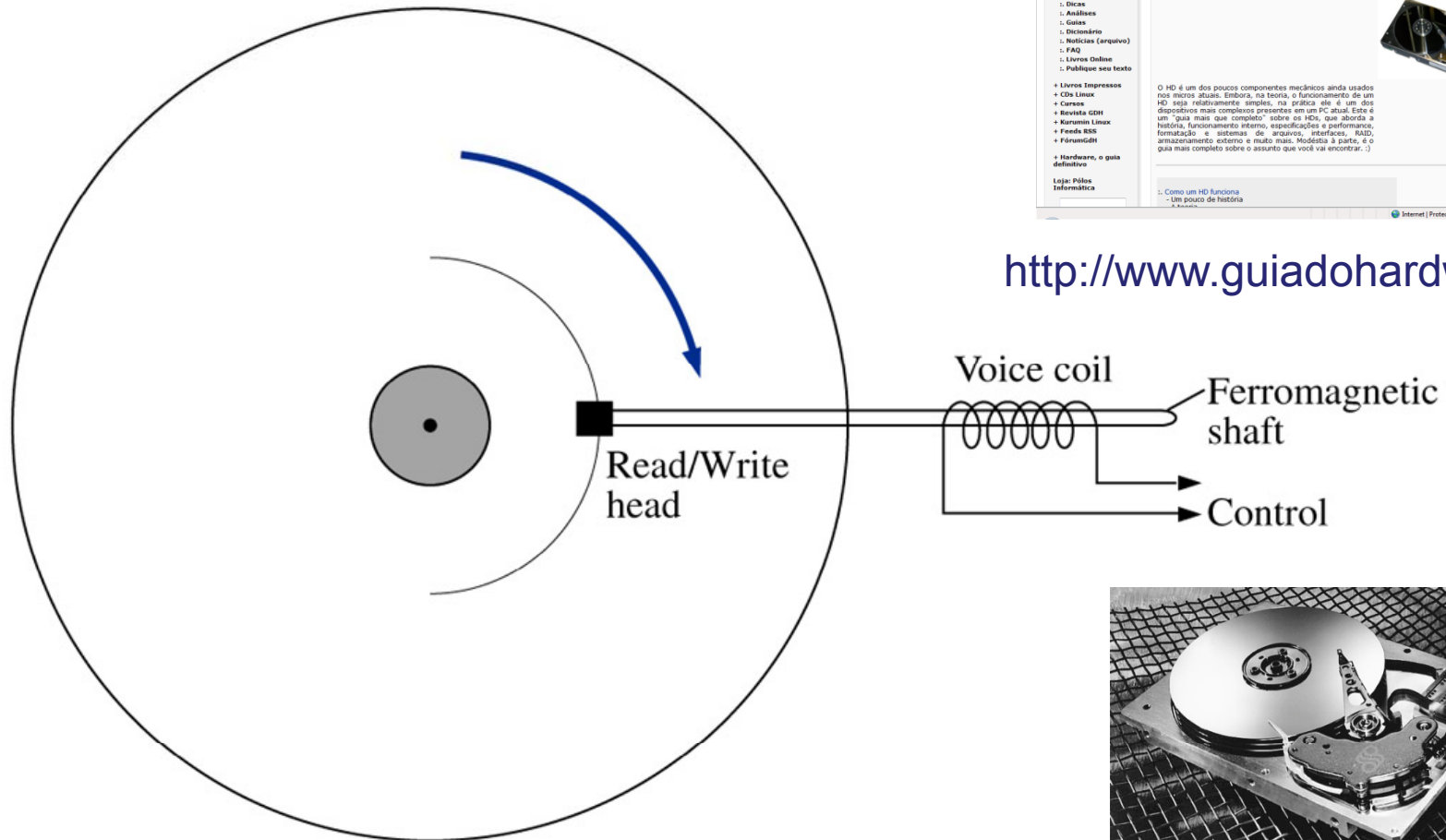

Aplicações – Sensor magnético (reed-switch)

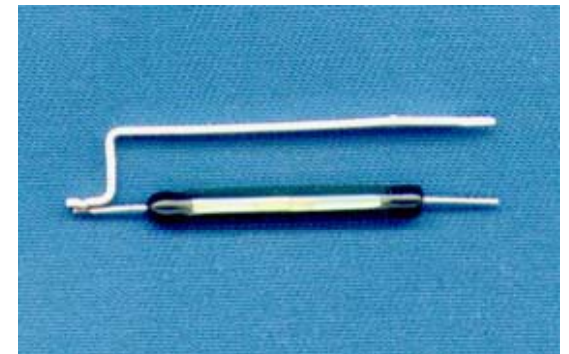
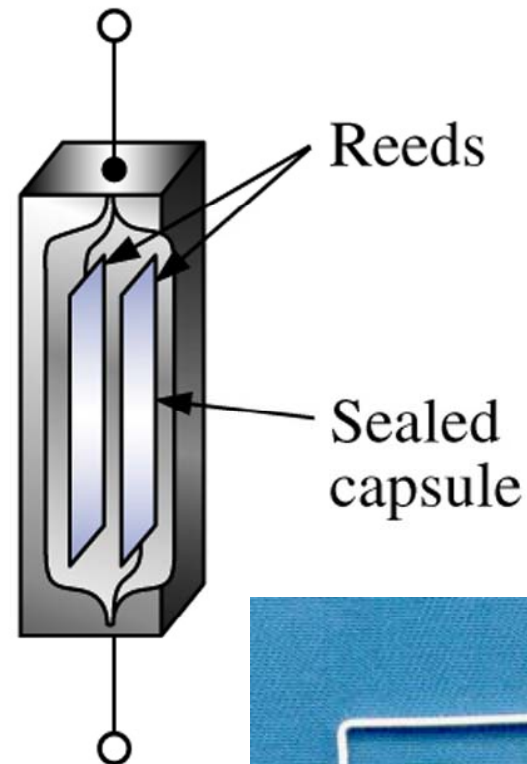
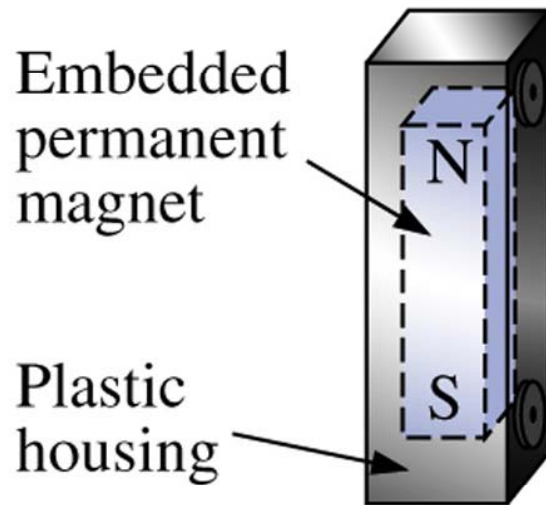

Aplicações - Relé

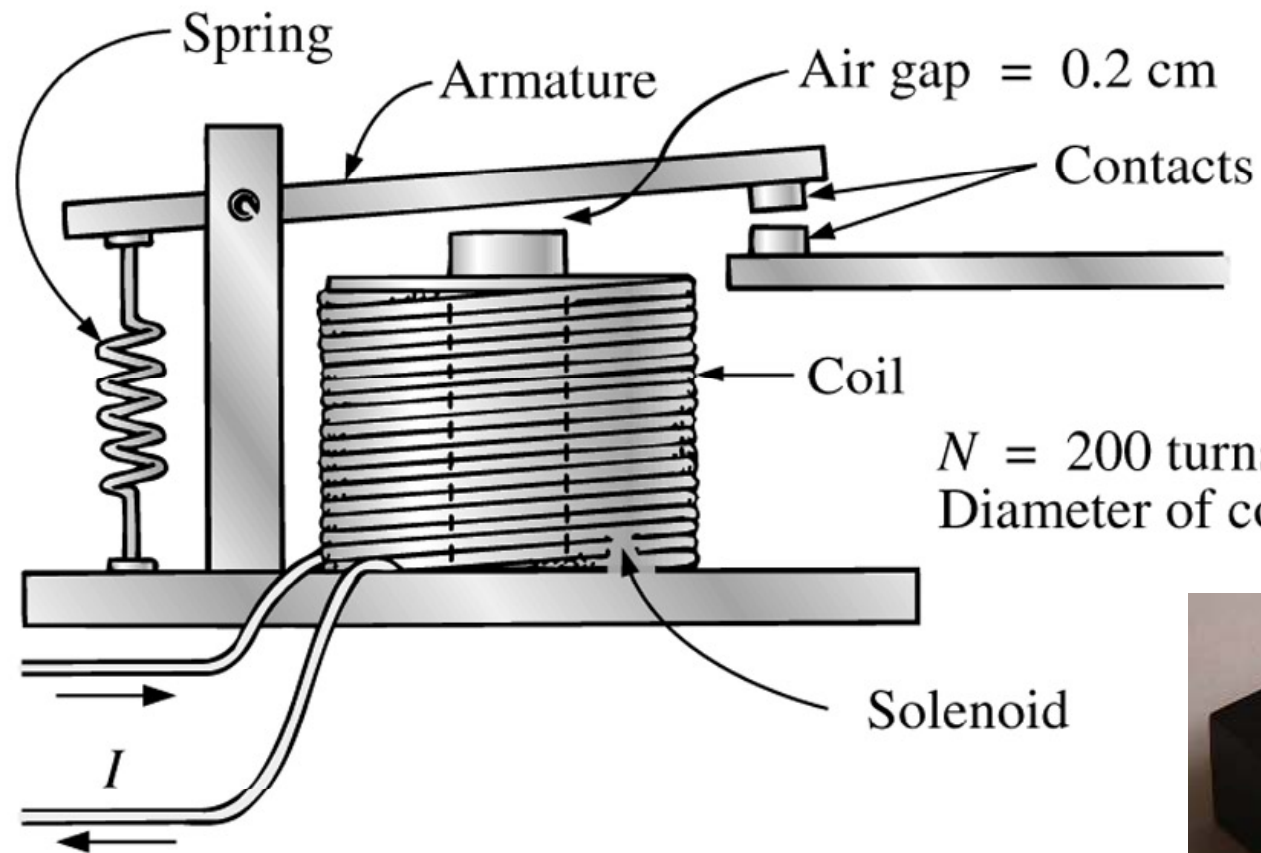

Aplicações – Indicador de velocidade

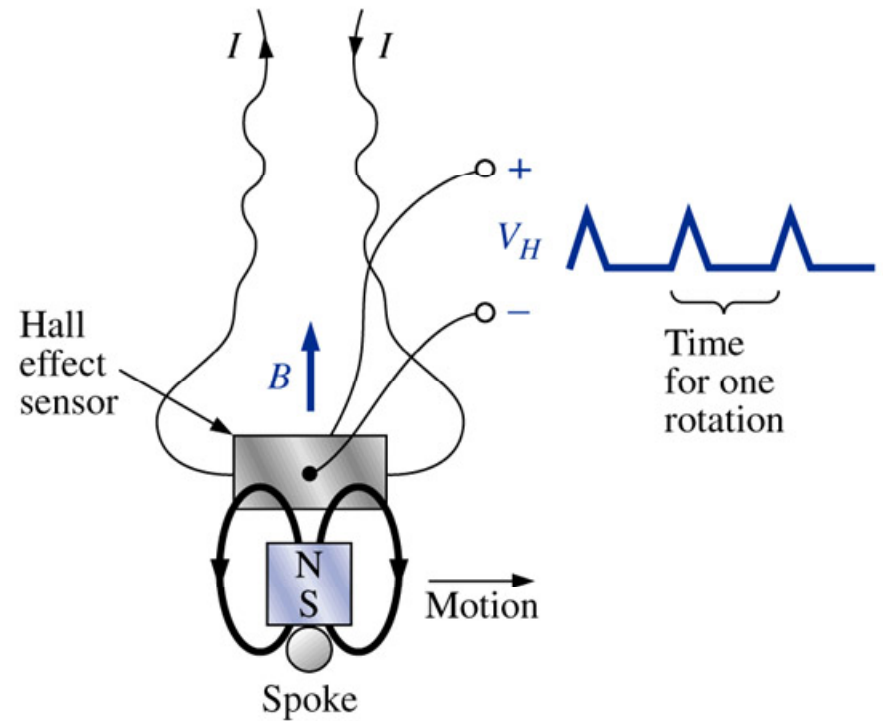
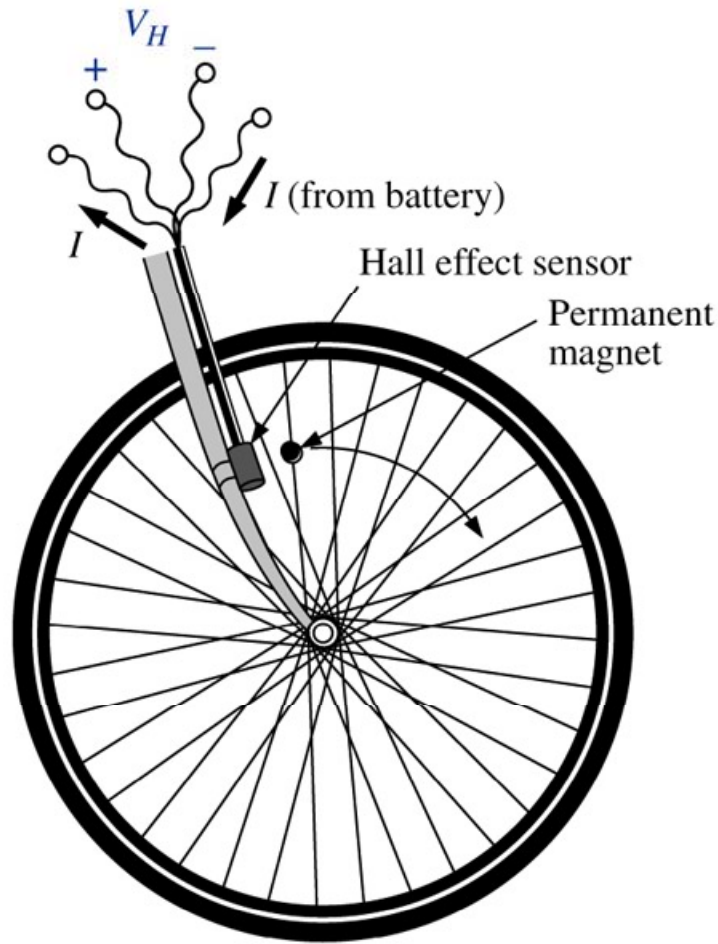

Na próxima aula

Capítulo 11: Circuitos magnéticos

1. Leis de Faraday e Lenz;
2. Auto-indutância;
3. Indutores.

