

**Centro Federal de Educação Tecnológica de Santa Catarina**  
**Departamento Acadêmico de Eletrônica**  
**Retificadores**



**Transformadores**  
**Parte 2**

**Prof. Clóvis Antônio Petry.**

**Florianópolis, setembro de 2008.**

# Bibliografia para esta aula

## Capítulo 21: Transformadores

1. Transformador com núcleo de ar;
2. Circuitos equivalentes de transformadores;
3. Impedância;
4. Potência;
5. Tipos de transformadores;
6. Aplicações de transformadores.

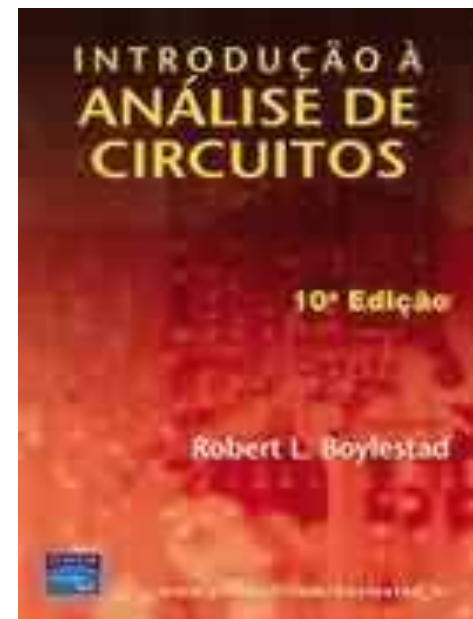

# Transformador com núcleo de ar

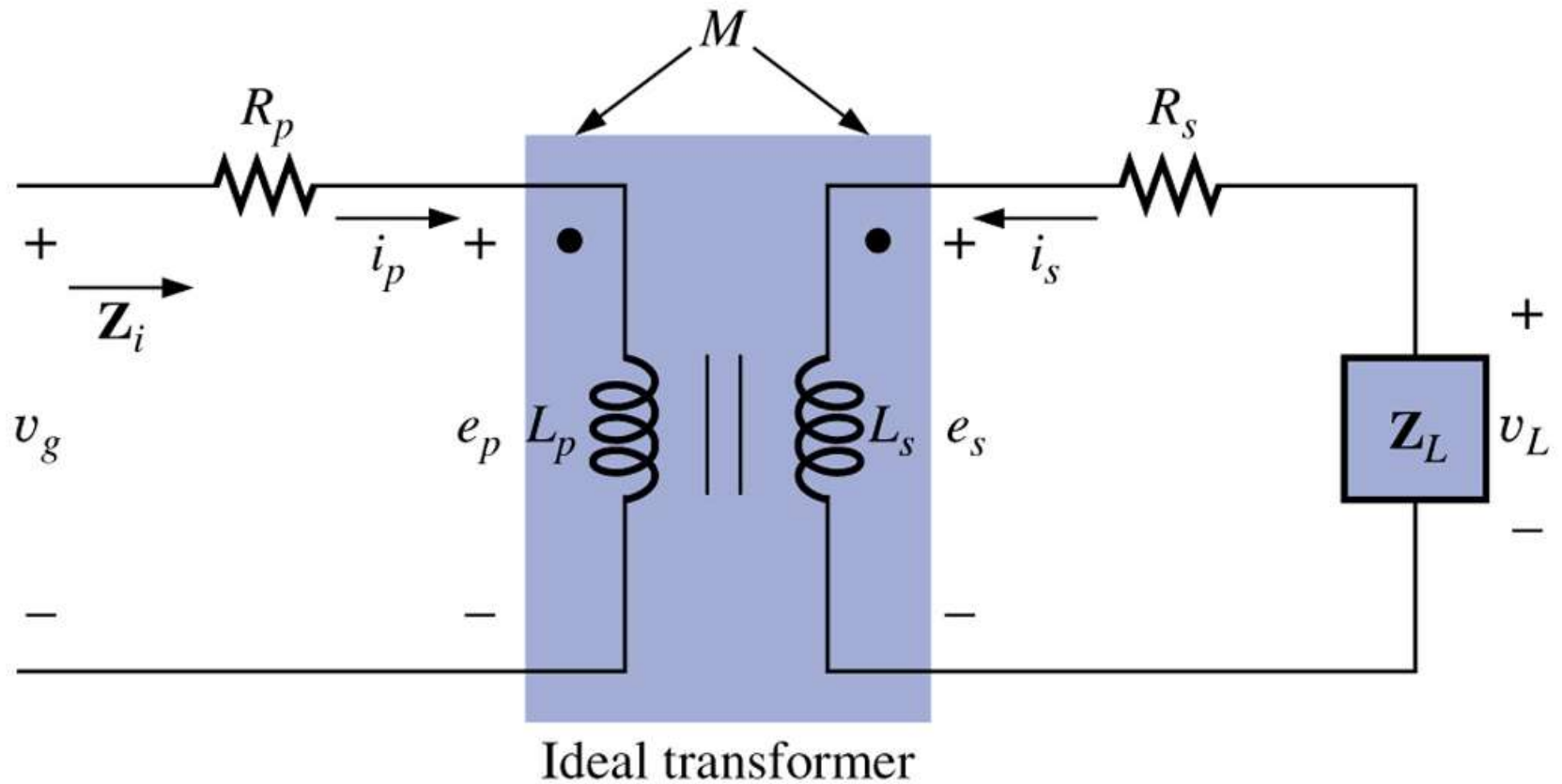

# Transformador com núcleo de ar

Tensão induzida no primário:

$$e_p = L_p \frac{di_p}{dt} + M \frac{di_s}{dt}$$

No domínio fasorial:

$$v_1 = L \frac{di_1}{dt}$$

$$V_1 = I_1 \cdot X_L \cdot \underline{90^\circ}$$

$$X_L = \omega \cdot L$$

$$v_1 = M \frac{di_2}{dt}$$

$$V_1 = I_2 \cdot X_m \cdot \underline{90^\circ}$$

$$X_m = \omega \cdot M$$

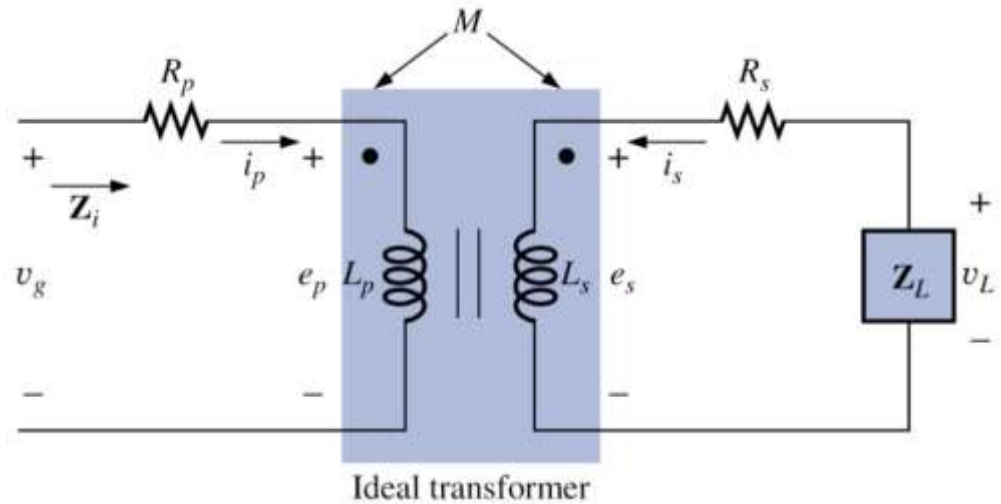

# Transformador com núcleo de ar

$$E_p = I_p \cdot X_{Lp} \cdot \underline{90^\circ} + I_s \cdot X_m \cdot \underline{90^\circ}$$

$$V_g = I_p \cdot R_p \cdot \underline{0^\circ} + I_p \cdot X_{Lp} \cdot \underline{90^\circ} + I_s \cdot X_m \cdot \underline{90^\circ}$$

$$E_s = I_s \cdot X_{Ls} \cdot \underline{90^\circ} + I_p \cdot X_m \cdot \underline{90^\circ}$$

$$V_L = I_s \cdot R_s \cdot \underline{0^\circ} + I_s \cdot X_{Ls} \cdot \underline{90^\circ} + I_p \cdot X_m \cdot \underline{90^\circ}$$

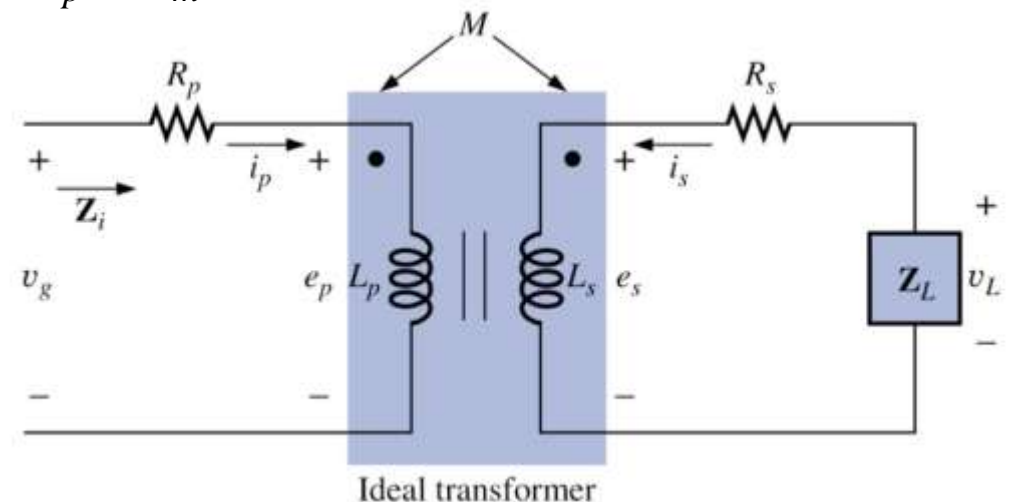

# Transformador com núcleo de ar

- Determine a tensão na saída do circuito a seguir;
- Determine a corrente na fonte do circuito abaixo.

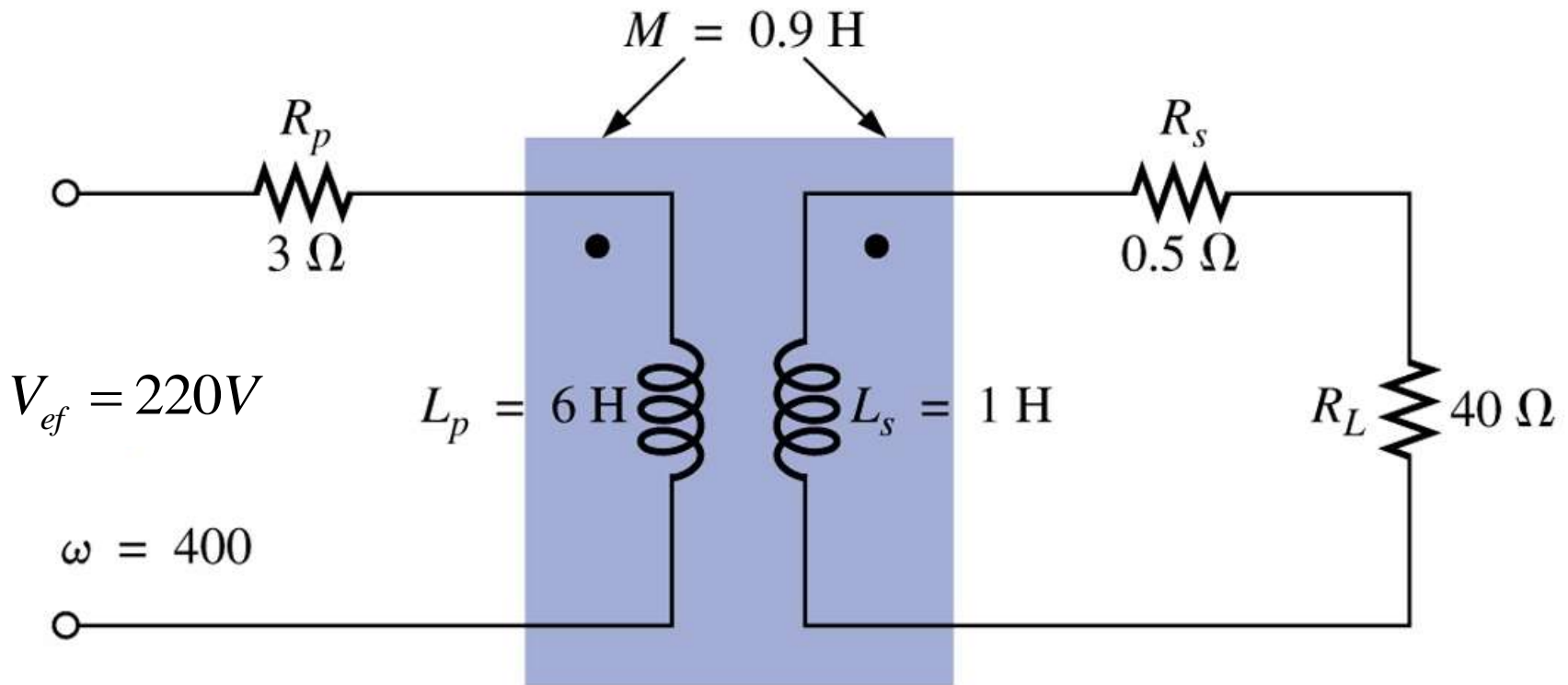

# Conexão de indutores acoplados

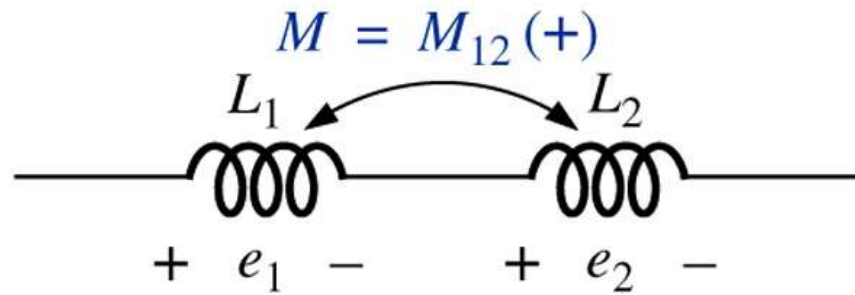

(a)

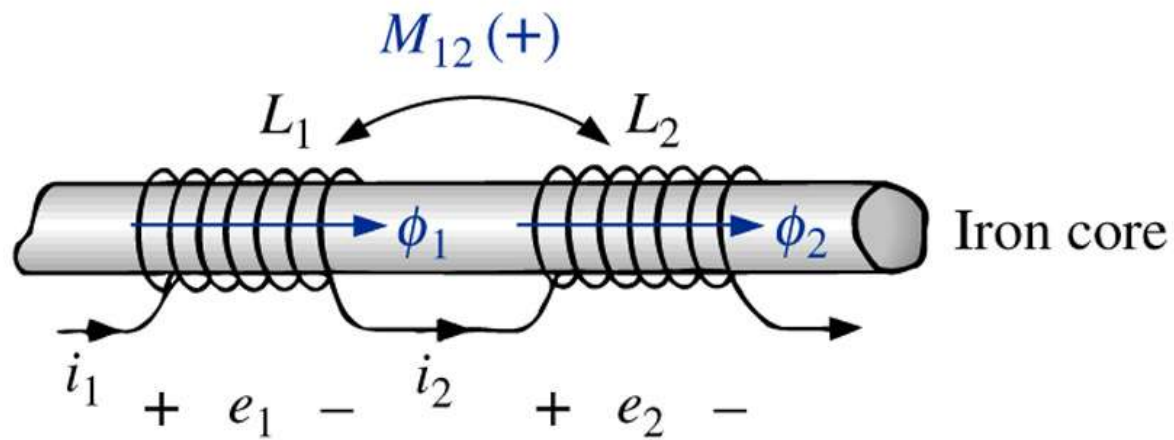

(b)

# Conexão de indutores acoplados

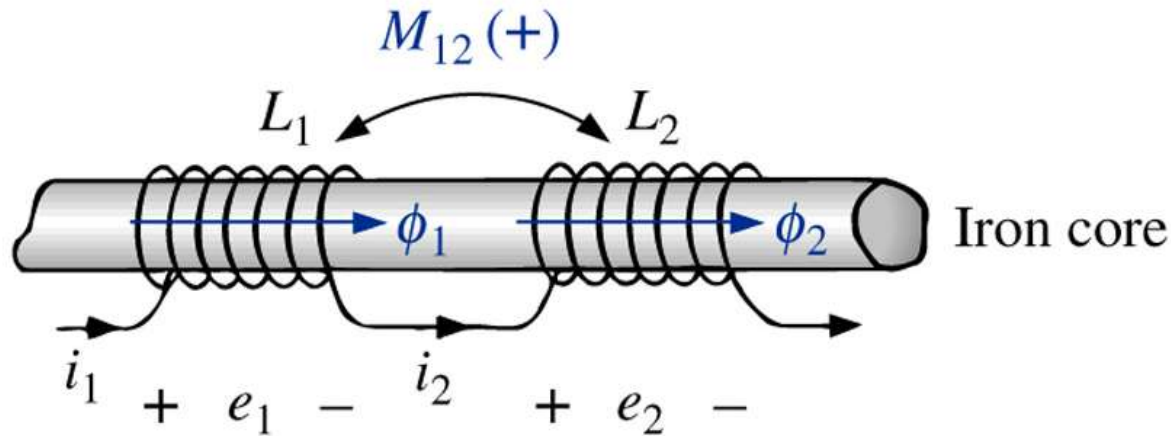

$$e_1 = L_1 \frac{di_1}{dt} + M_{12} \frac{di_2}{dt}$$

$$e_2 = L_2 \frac{di}{dt} + M_{12} \frac{di}{dt} = (L_2 + M_{12}) \frac{di}{dt}$$

$$i_1 = i_2 = i$$

$$e_T = e_1 + e_2 = (L_1 + M_{12}) \frac{di}{dt} + (L_2 + M_{12}) \frac{di}{dt}$$

$$e_1 = L_1 \frac{di}{dt} + M_{12} \frac{di}{dt} = (L_1 + M_{12}) \frac{di}{dt}$$

$$L_{T(+)} = L_1 + L_2 + 2M_{12}$$

# Conexão de indutores acoplados

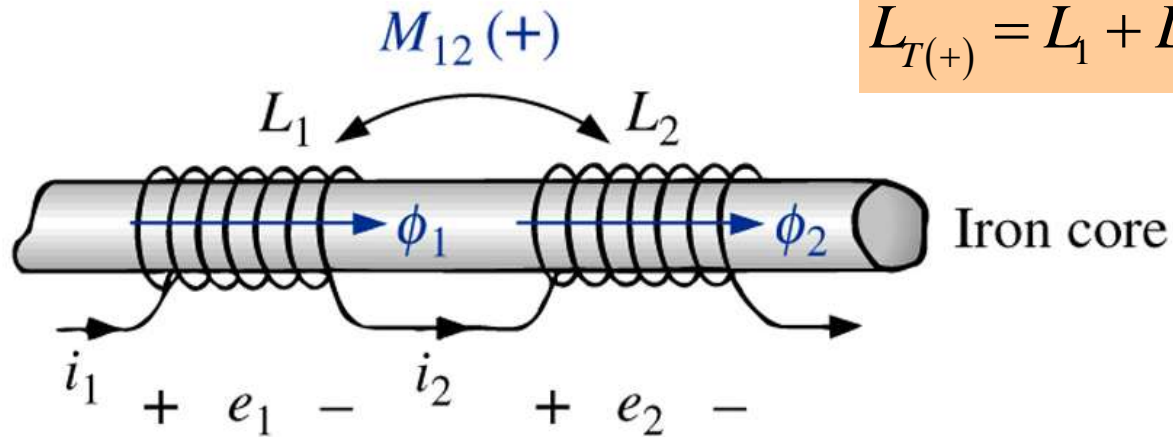

$$L_{T(+)} = L_1 + L_2 + 2M_{12}$$

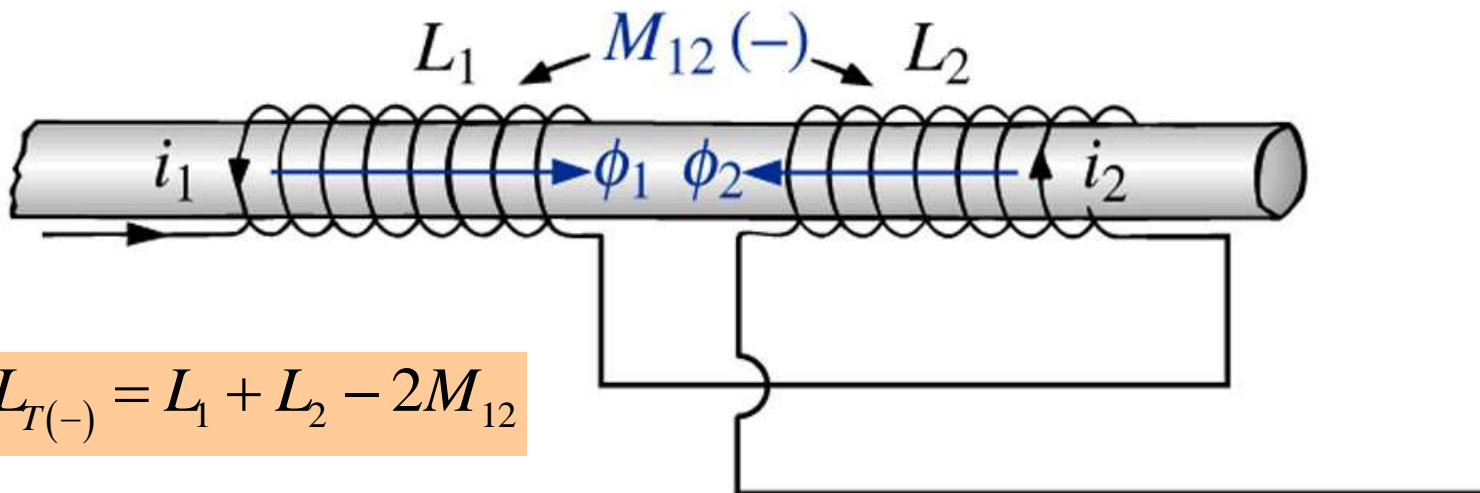

$$L_{T(-)} = L_1 + L_2 - 2M_{12}$$

# Indutores acoplados – convenção do ponto



(a)



(b)

# Enrolamentos acoplados – convenção do ponto

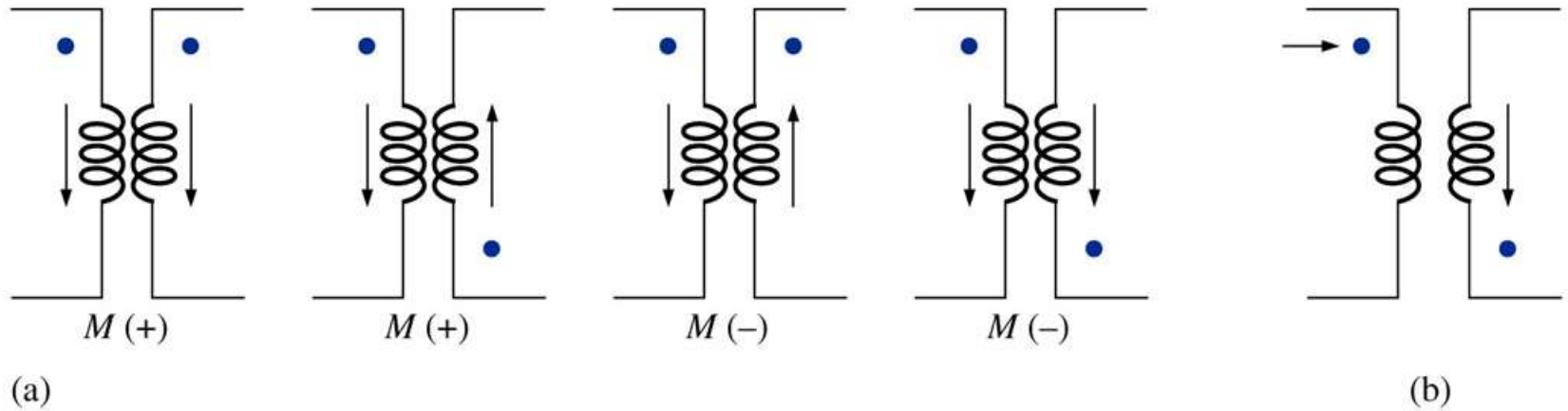

# Circuito equivalente do transformador

Circuito equivalente completo de um transformador de núcleo de ferro real:

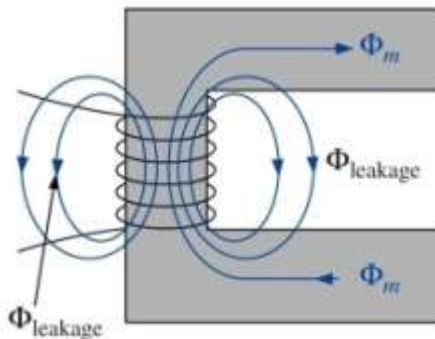
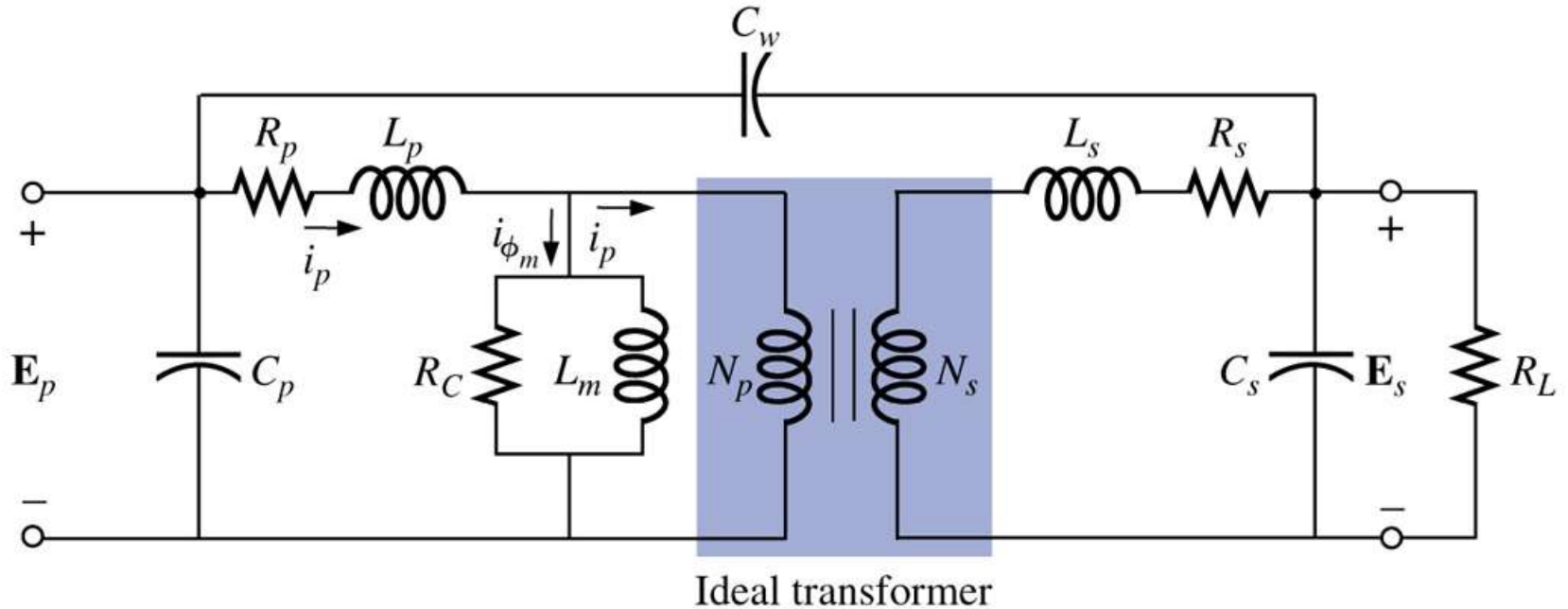

# Circuito equivalente do transformador

Circuito equivalente reduzido do transformador de núcleo de ferro real:

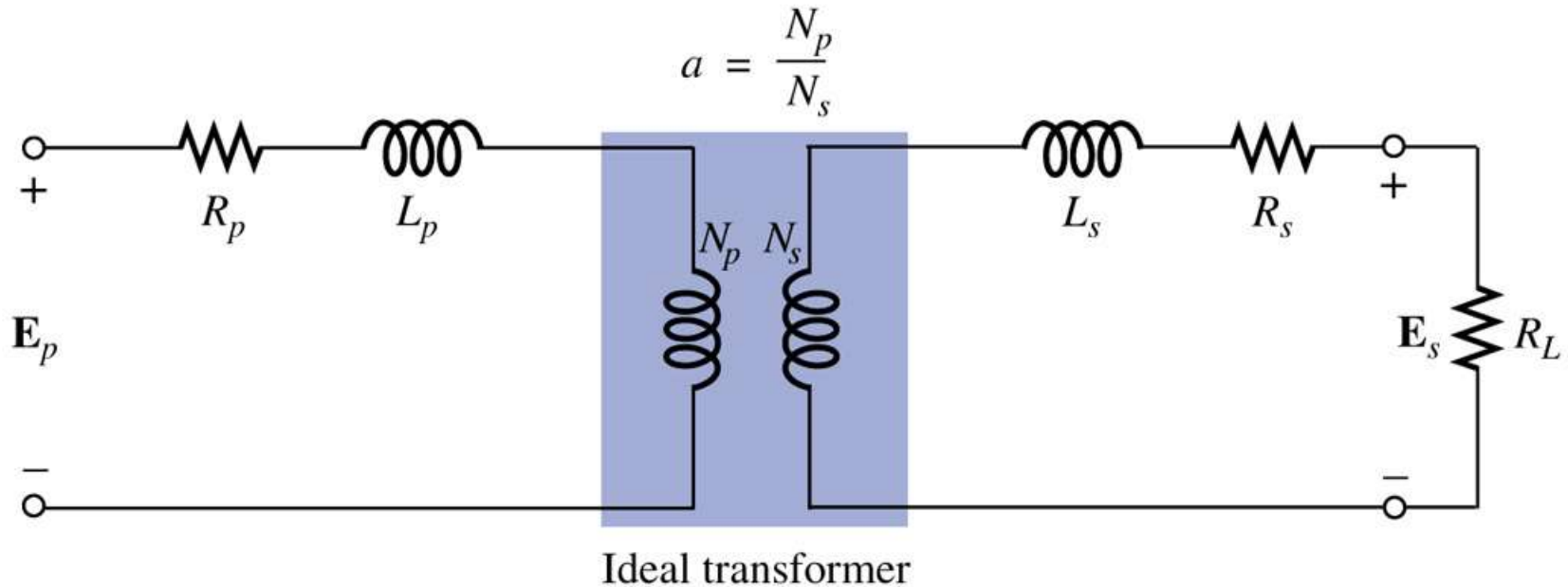

$$R_{\text{equivalente}} = R_e = R_p + a^2 R_s$$

$$X_{\text{equivalente}} = X_e = X_p + a^2 X_s$$

# Circuito equivalente do transformador

Circuito equivalente referido ao primário:

$$R_{equivalente} = R_e = R_p + a^2 R_s$$

$$X_{equivalente} = X_e = X_p + a^2 X_s$$

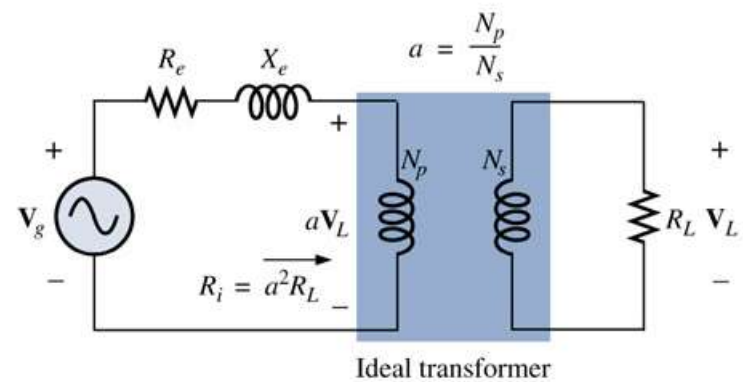
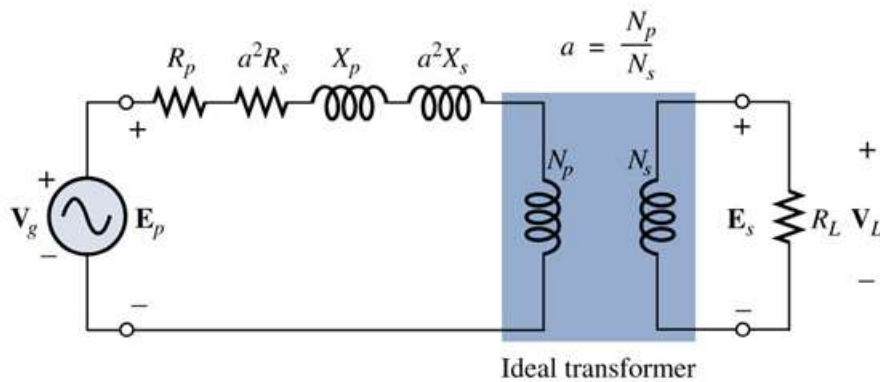

# Circuito equivalente do transformador

Efeito da freqüência:

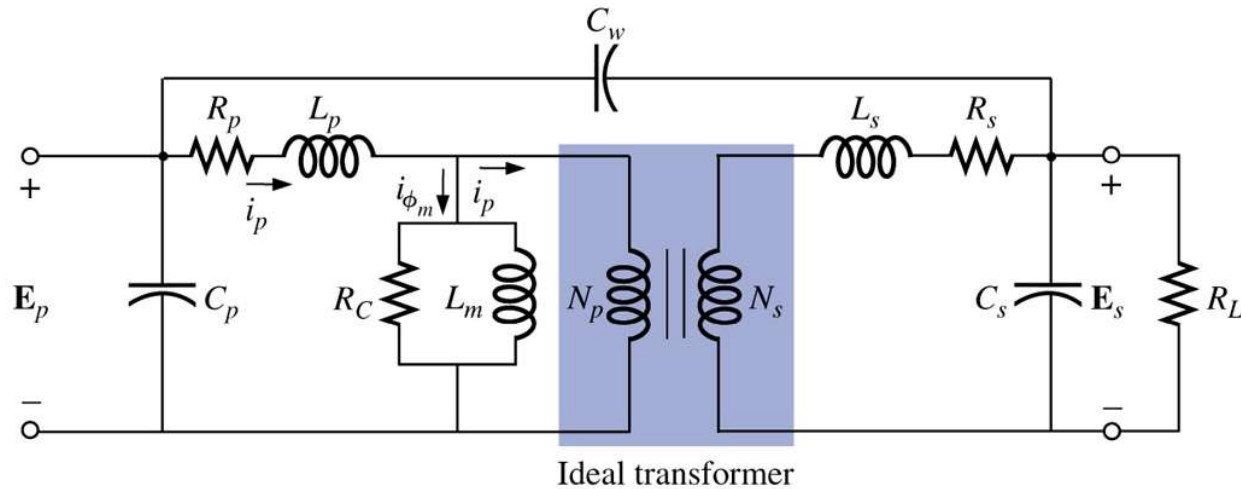

Circuito equivalente para baixas freqüências

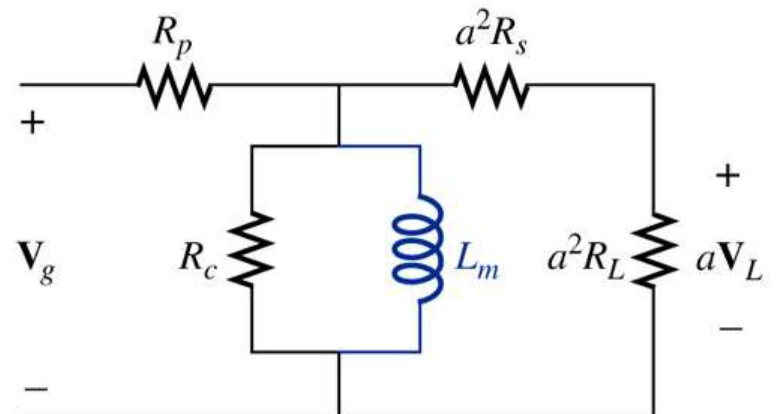

# Circuito equivalente do transformador

Efeito da freqüência:

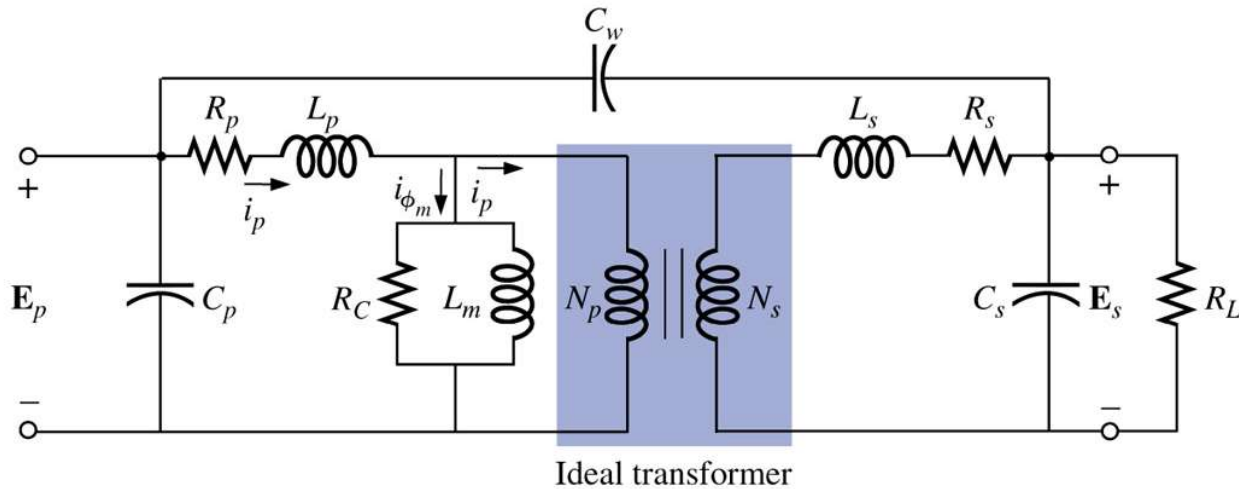

Circuito equivalente para médias freqüências

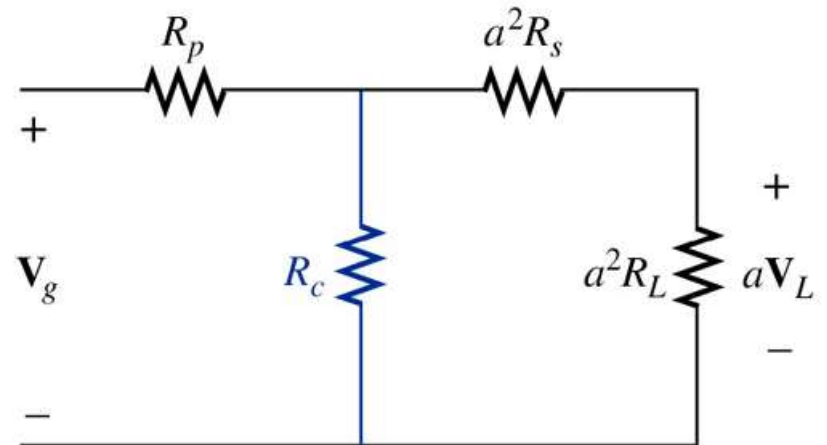

# Impedância referida

Relações importantes:

$$\frac{V_p}{V_s} = \frac{N_p}{N_s} = a \qquad \frac{I_p}{I_s} = \frac{N_s}{N_p} = \frac{1}{a}$$

Dividindo as expressões acima:

$$\frac{V_p / V_s}{I_p / I_s} = \frac{a}{1/a} \qquad \frac{V_p / I_p}{V_s / I_s} = a^2$$

$$\frac{V_p / I_p}{V_s / I_s} = \frac{Z_p}{Z_s} = a^2$$

$$Z_p = a^2 \cdot Z_s$$

# Potência do transformador

Considerando o transformador ideal:

$$\frac{E_p}{E_s} = a = \frac{I_s}{I_p}$$

$$E_p \cdot I_p = E_s \cdot I_s$$

$$P_{\text{entrada}} = P_{\text{saída}}$$

# Transformadores com derivação

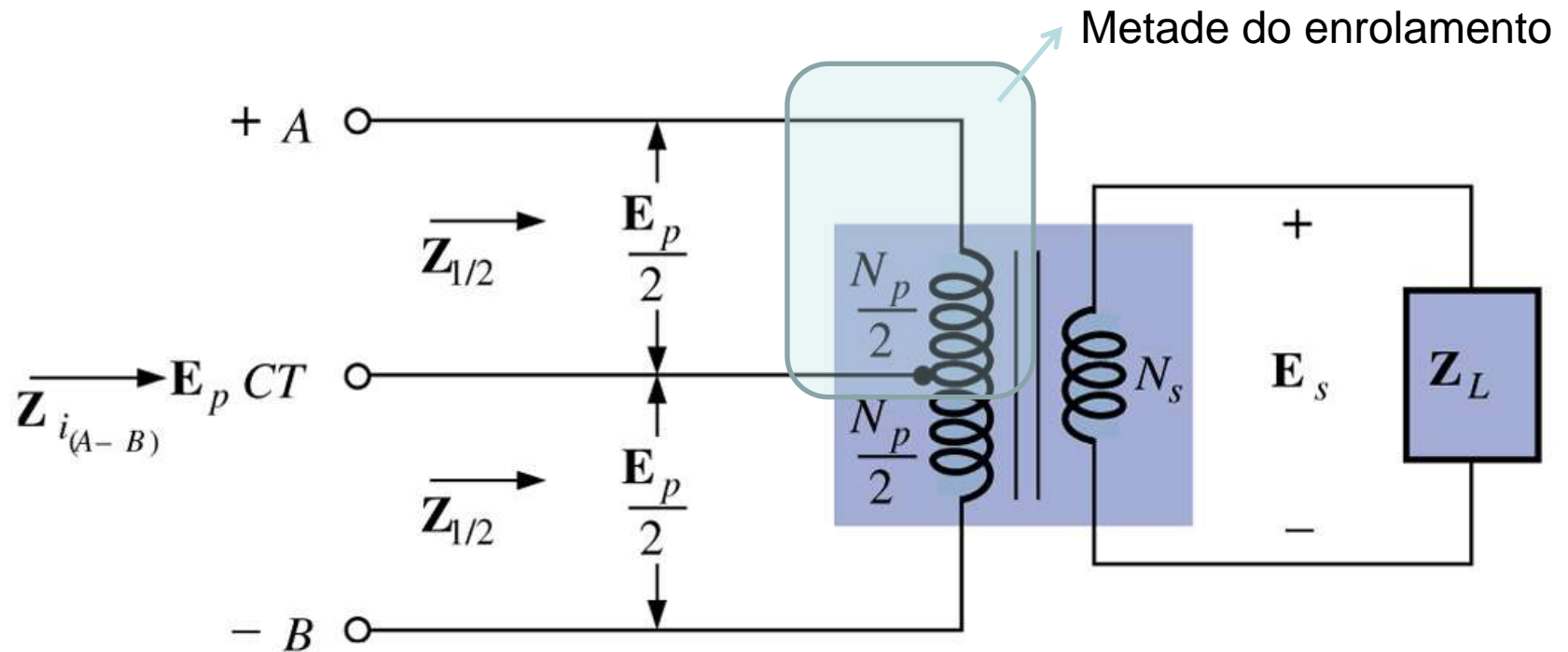

$$\frac{E_p}{E_s} = \frac{N_p}{N_s} = a$$

# Transformadores com dois secundários

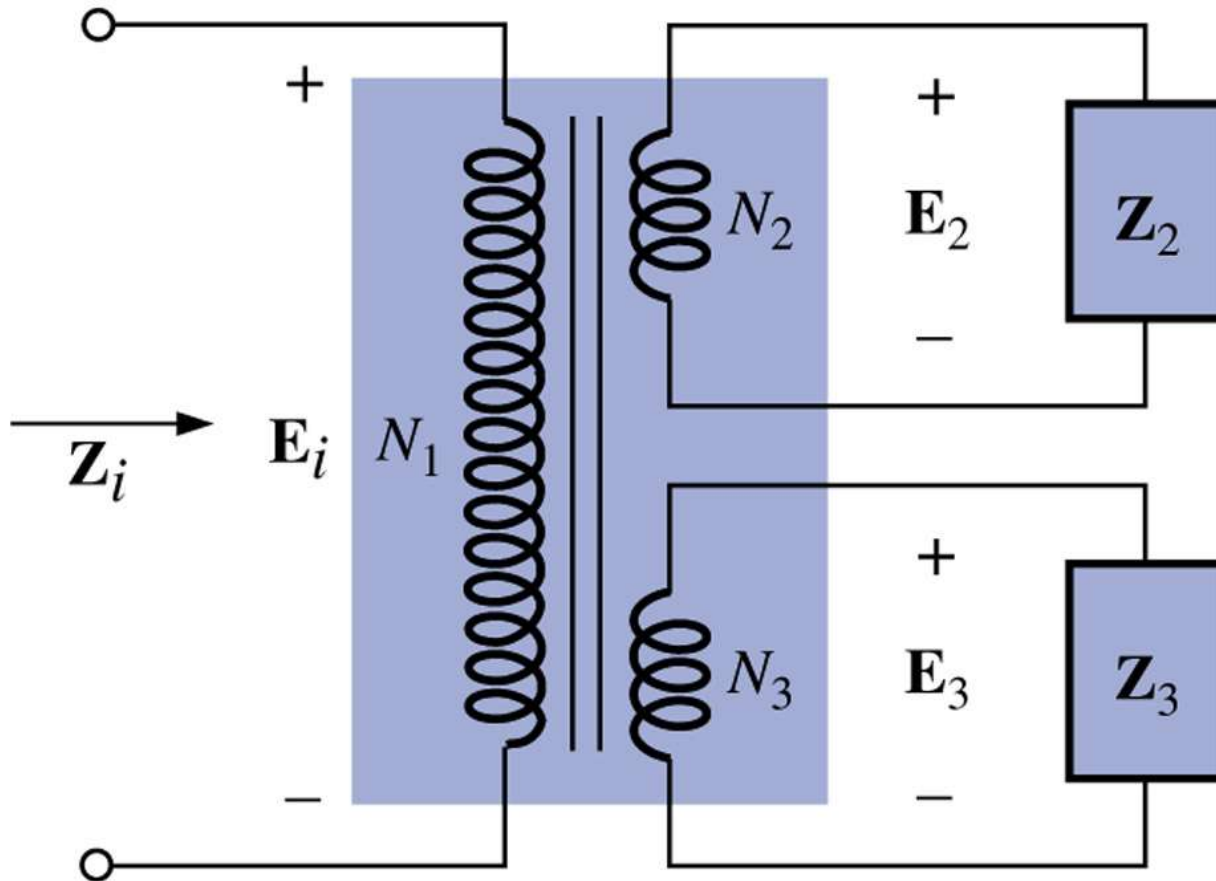

$$P_p = P_{s1} + P_{s2}$$

# Tipos e aplicações

## Casamento de impedância:

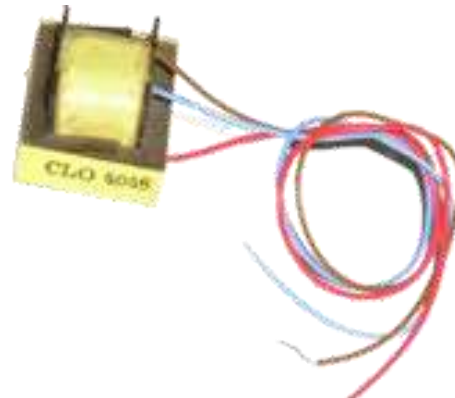
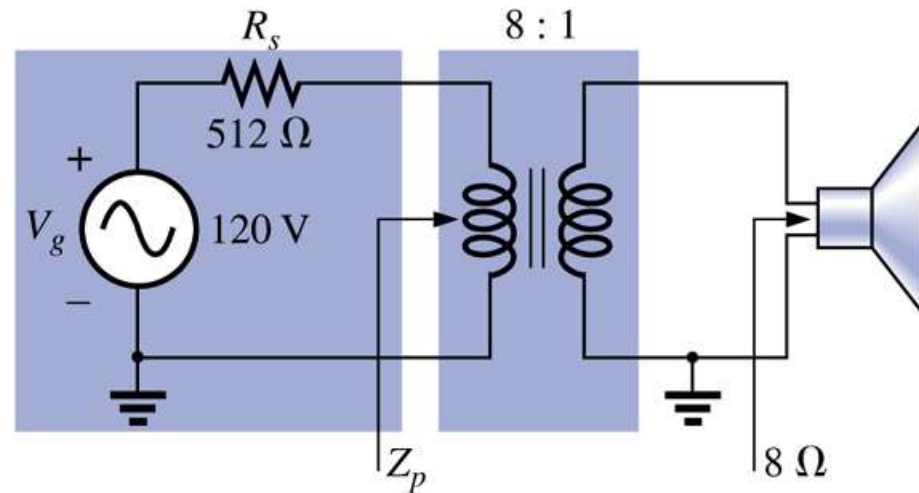
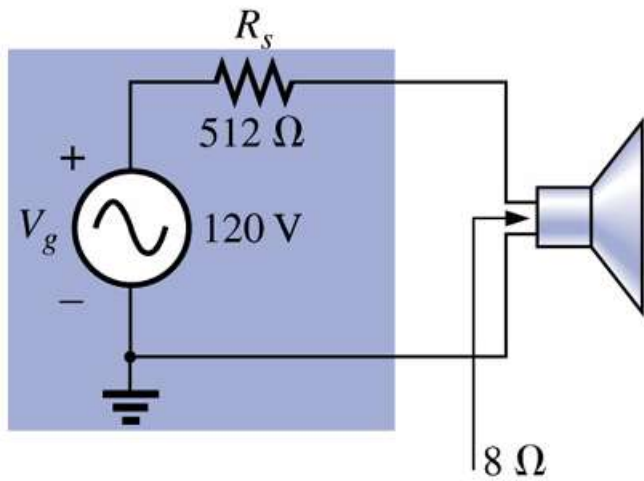

# Tipos e aplicações

Casamento de impedância:

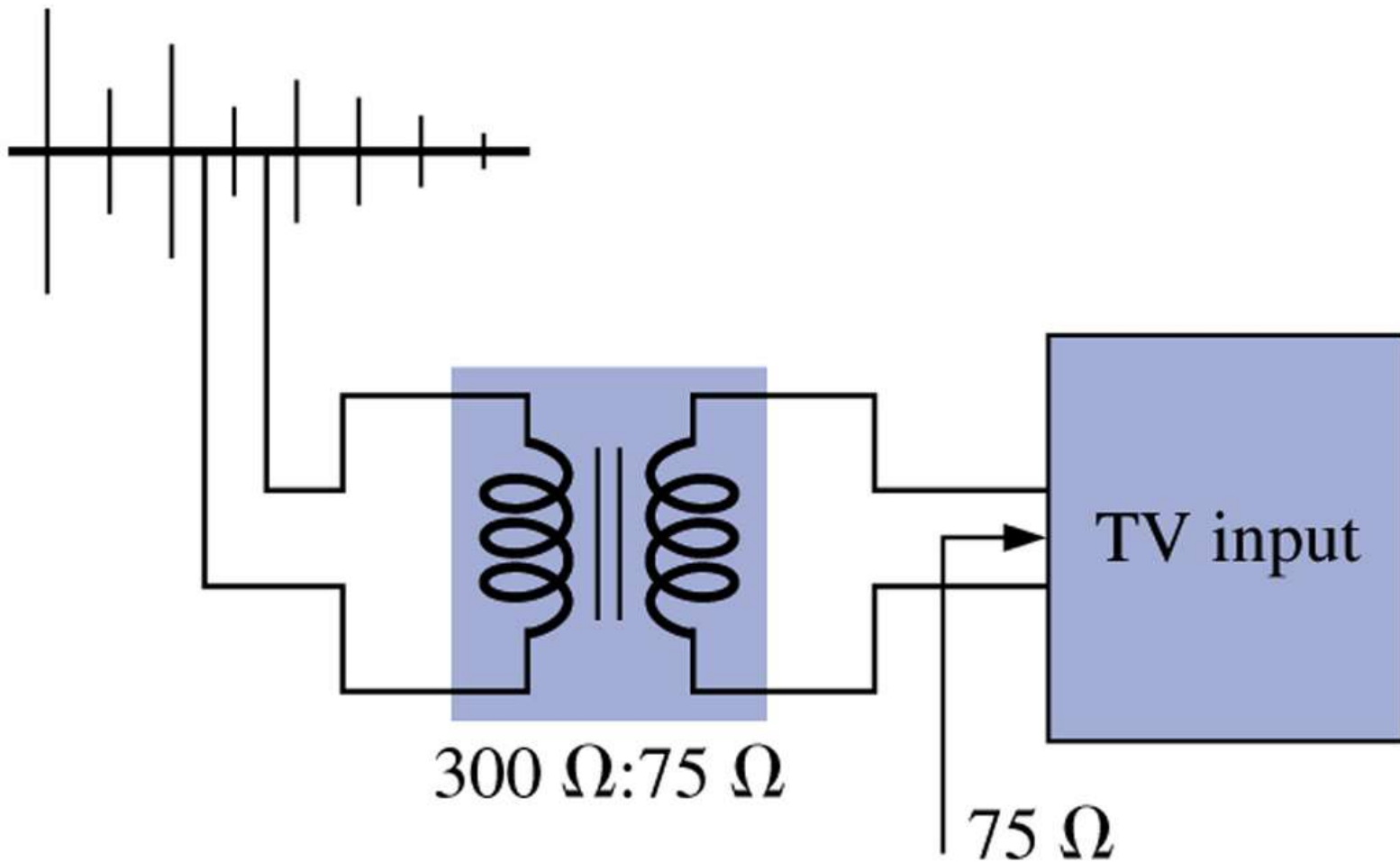

# Tipos e aplicações

## Casamento de impedância:

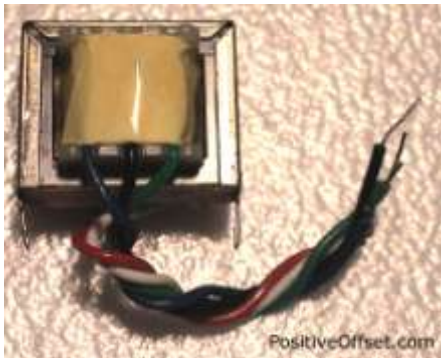
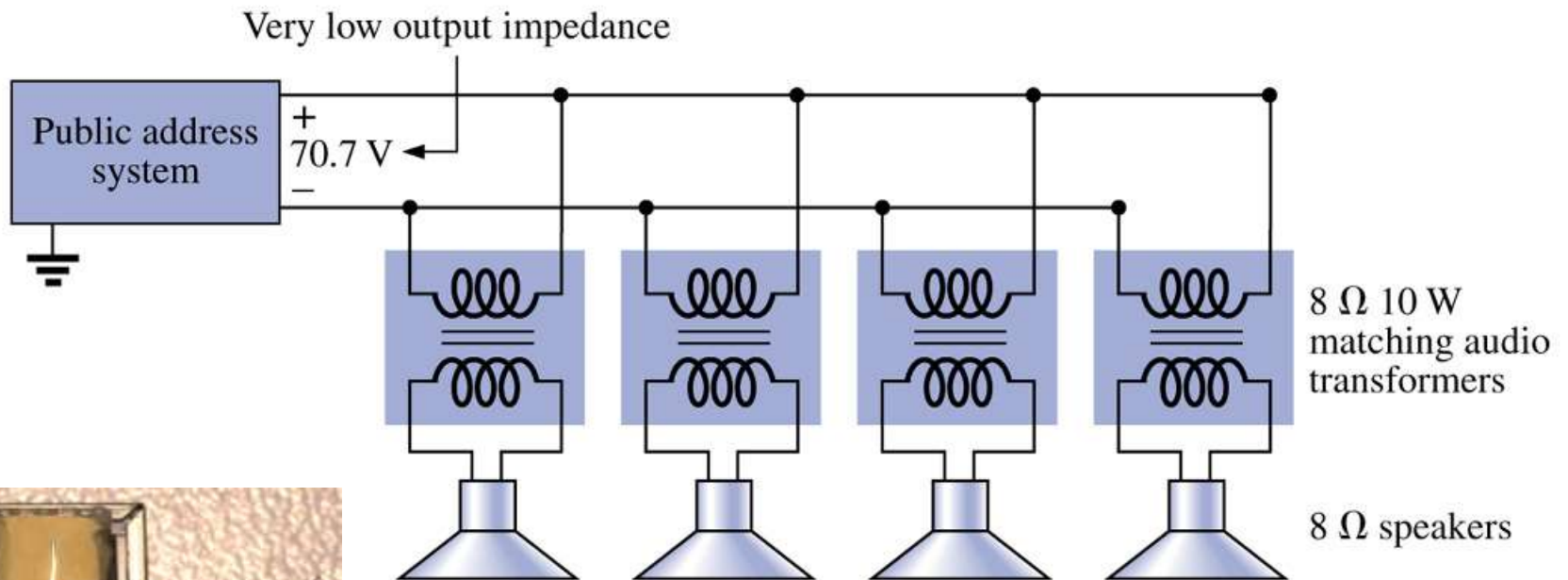

# Tipos e aplicações

**Casamento de impedância (rádio-freqüência):**

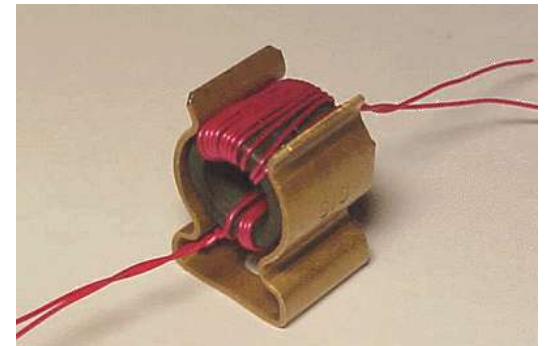

# Tipos e aplicações

## Transformador para medidas:

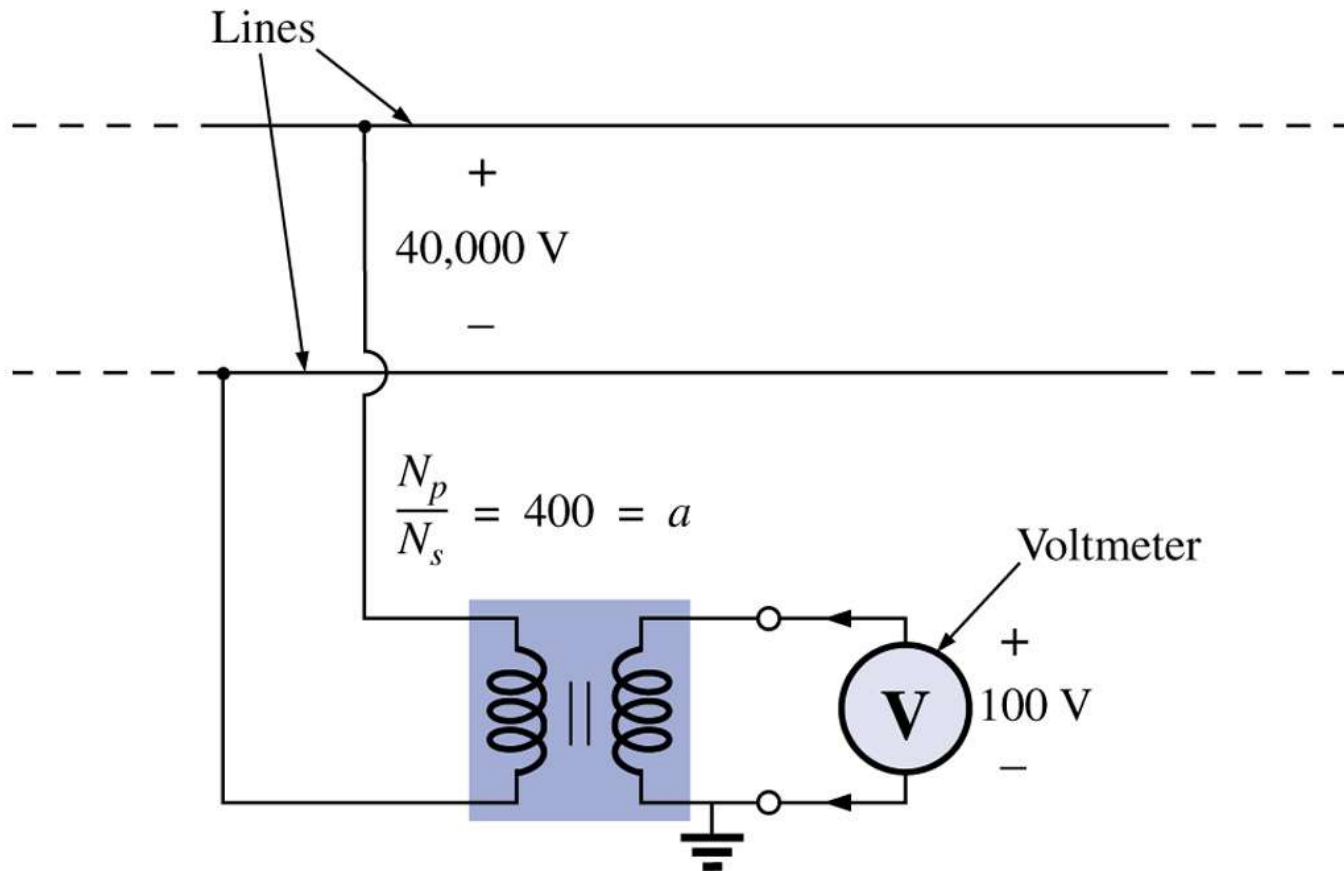

# Tipos e aplicações

Transformador para medidas (de potencial):

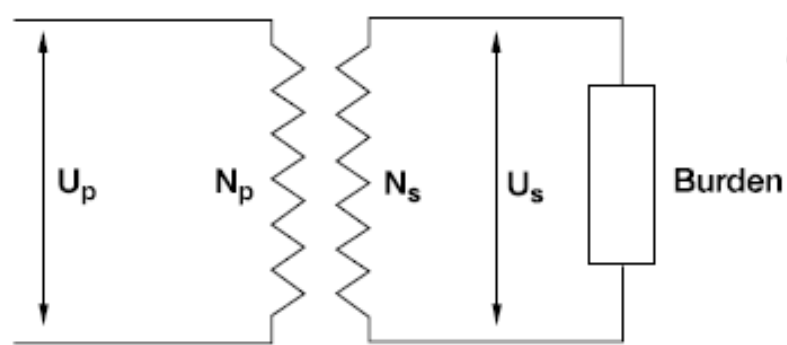

# Tipos e aplicações

Transformador para medidas (de corrente):

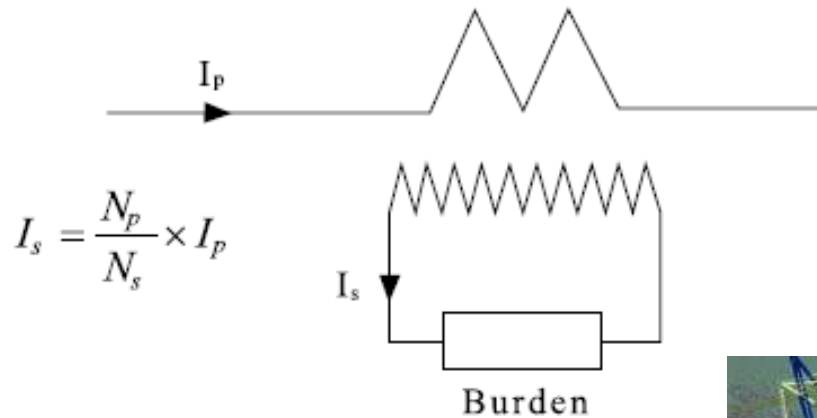

# Tipos e aplicações

Transformador para medidas (isolamento):

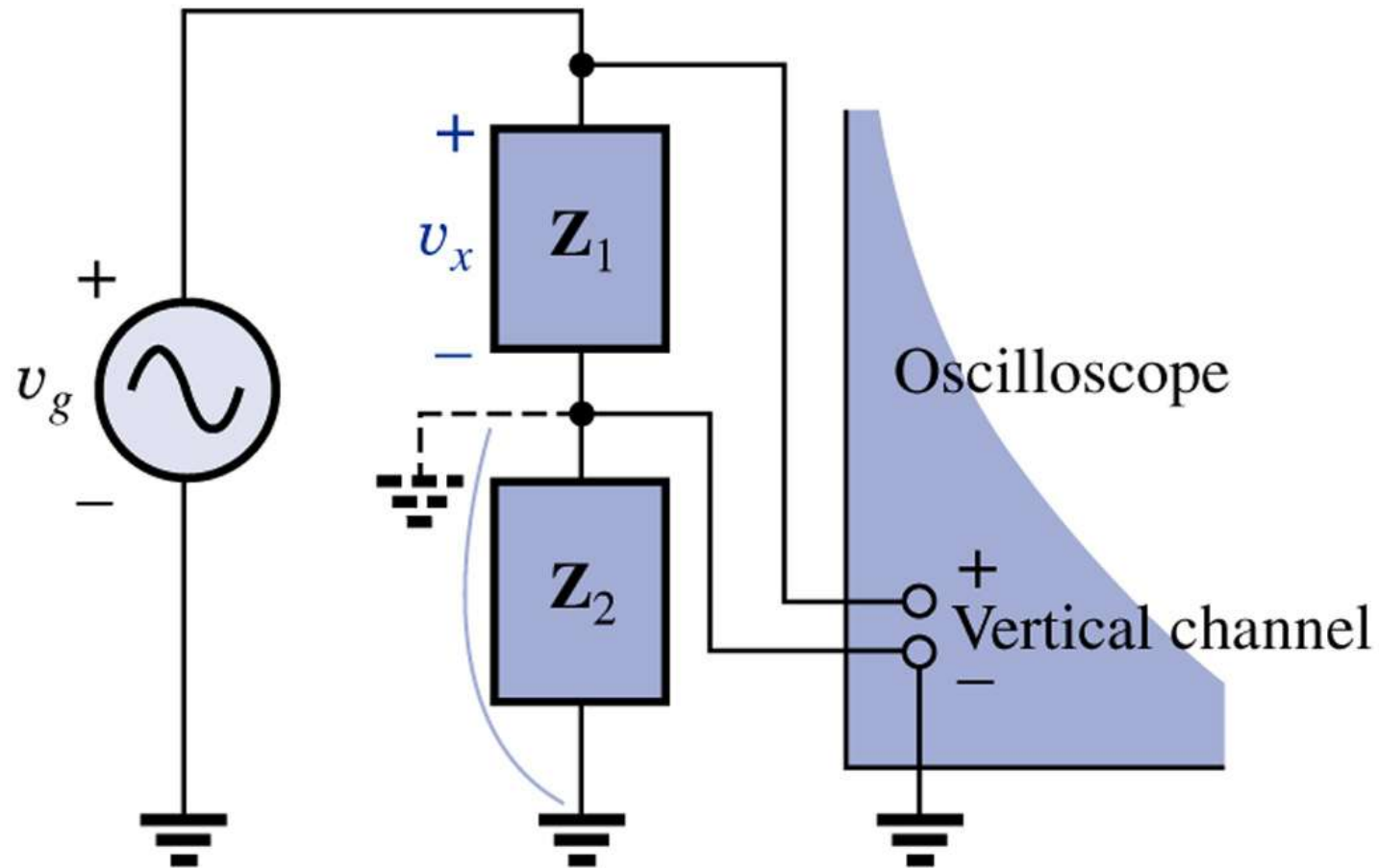

# Tipos e aplicações

Transformador para medidas (isolamento):

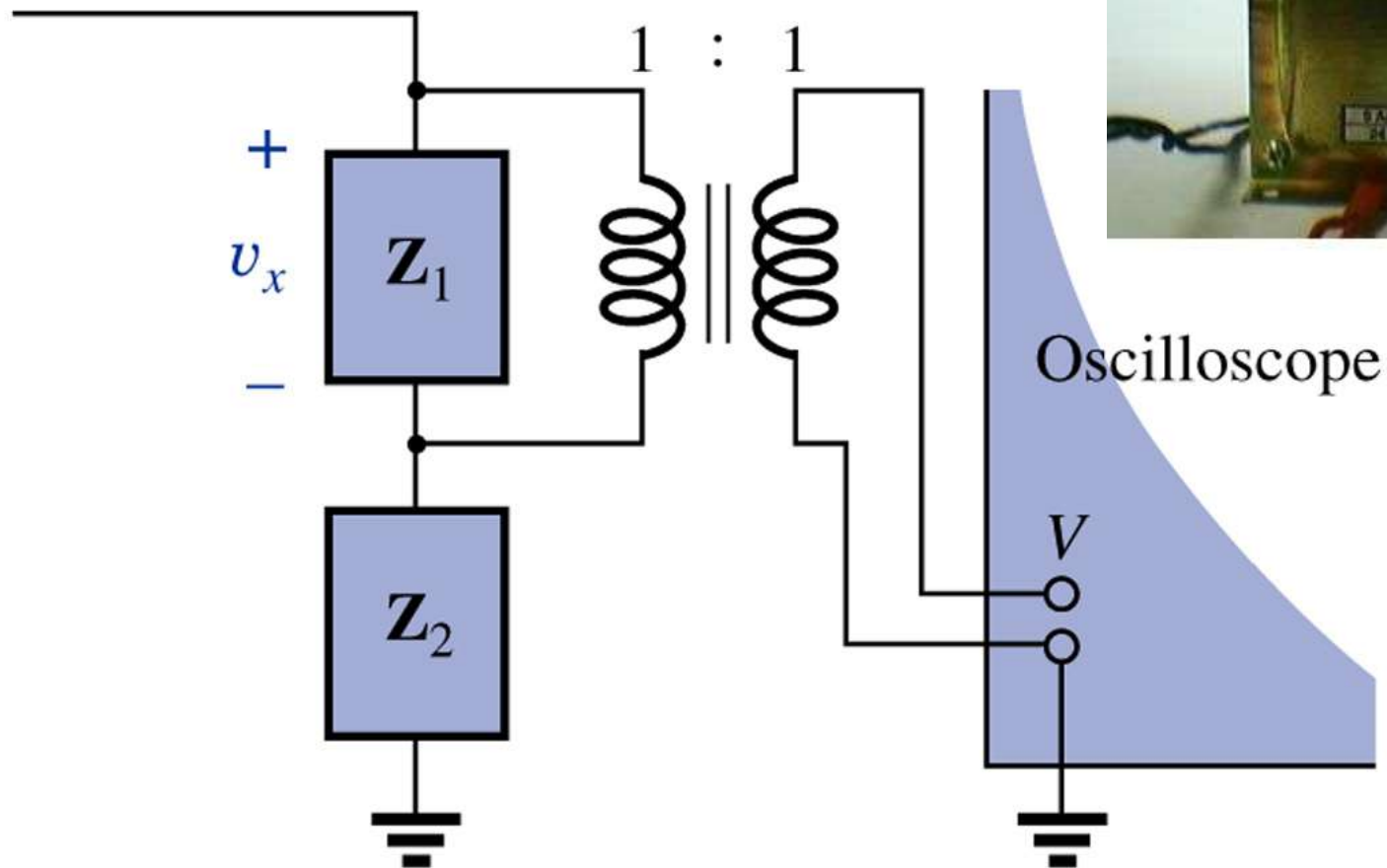

Oscilloscope

V

# Tipos e aplicações

## Transformador sensor de posição (LVDT – Linear variable differential transformer):

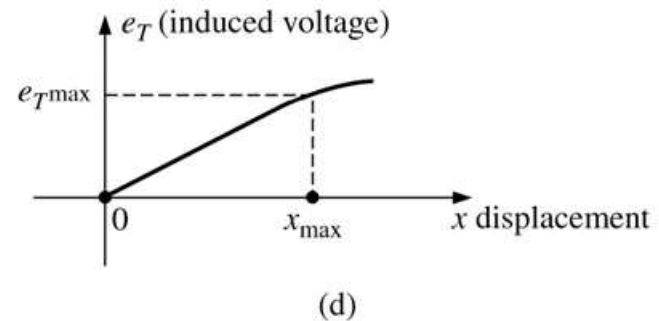
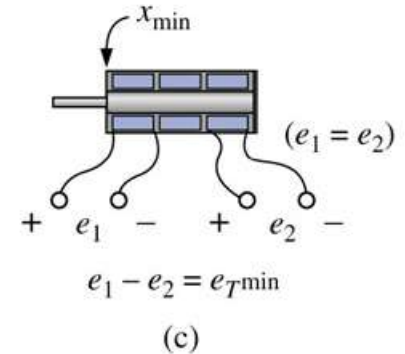
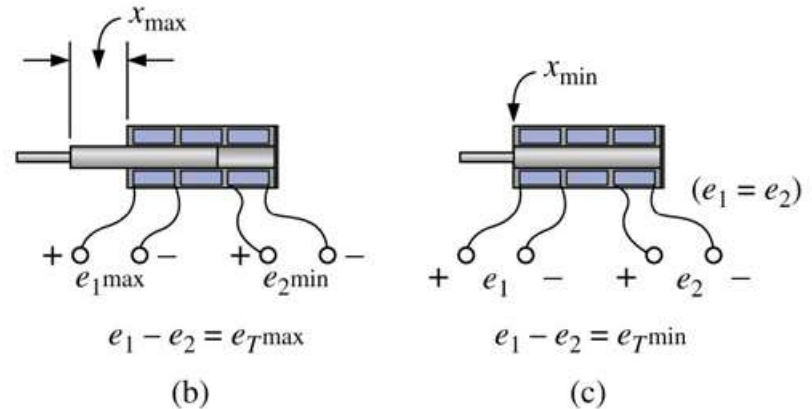
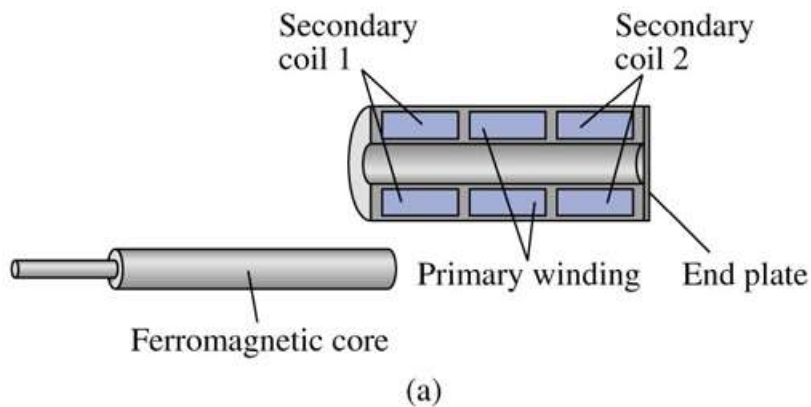

# Tipos e aplicações

## Compensador de baixa tensão:

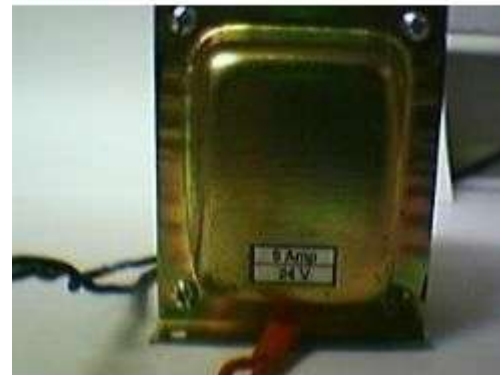
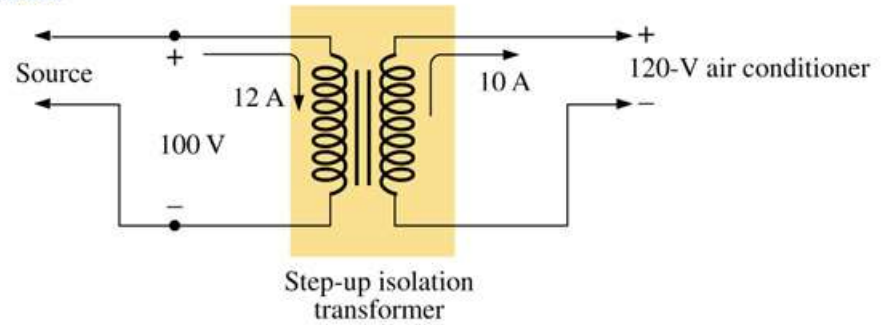
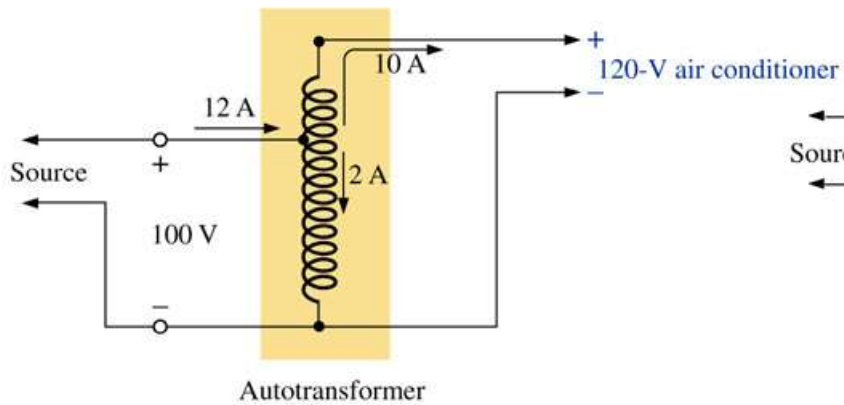

# Tipos e aplicações

## Transformador para lâmpada fluorescente:

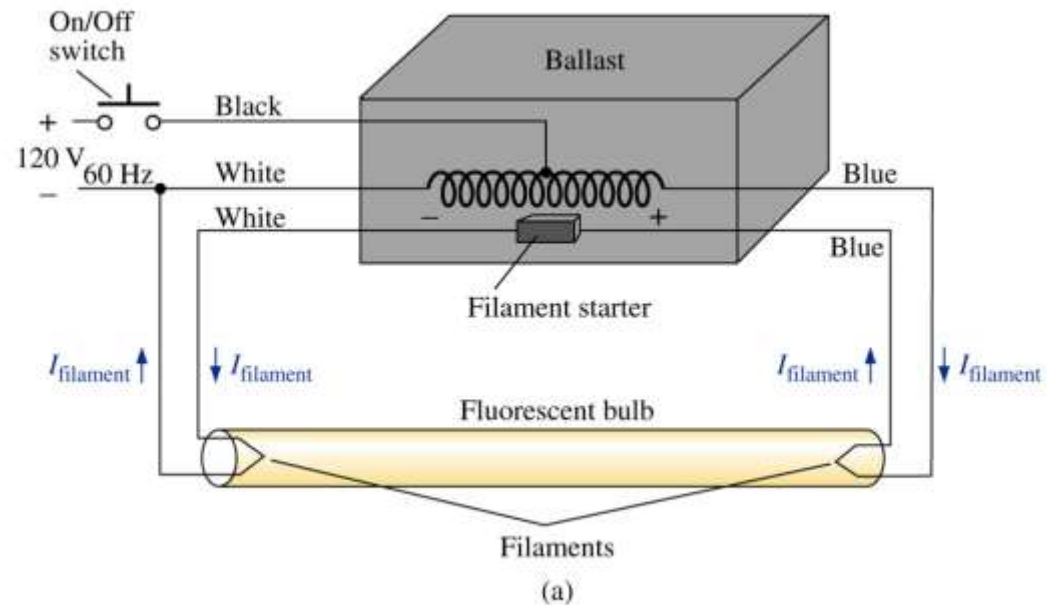
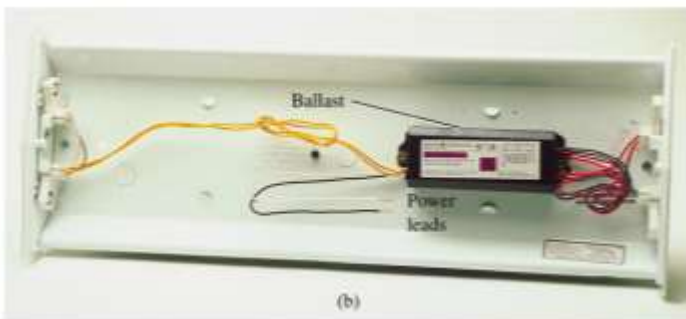

# Tipos e aplicações

## Transformadores de potência:

### TRANSFORMADORES DE DISTRIBUIÇÃO

Características:

- Potências: 15 a 500 kVA
- Classe de tensão: 15 ou 24,2 kV

Aplicações:

Para distribuição de energia (concessionárias de energia, cooperativas, instaladoras e empresas em geral).



# Tipos e aplicações

## Transformadores de potência:

### TRANSFORMADORES SECO

#### Características

- Potências: 300 a 3.000 kVA
- Classe de tensão: 15; 24,2 ou 36,2 kV

#### Aplicações

Os transformadores seco WEG podem substituir com vantagens os transformadores a óleo, principalmente nas aplicações onde a segurança é fator preponderante.

Utilizações típicas para este tipo de transformador:

- Plantas industriais, plantas químicas e petroquímicas, plataformas *off-shore*, edifícios comerciais, hospitais, embarcações marítimas, *shopping centers*, unidades de tratamento de água, aeroportos, centros de entretenimento, etc.



# Tipos e aplicações

## Transformadores para fontes de alimentação:

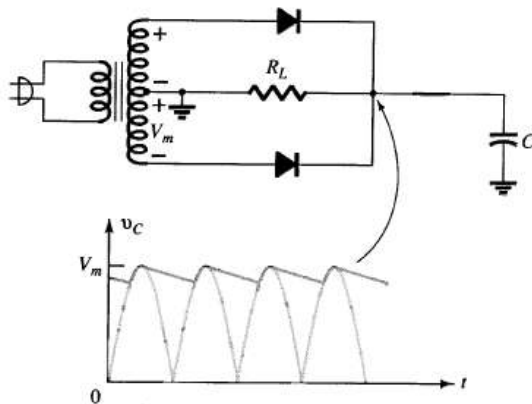

# Tipos e aplicações

**Transformadores para alta frequência:**

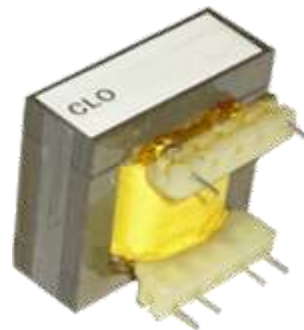
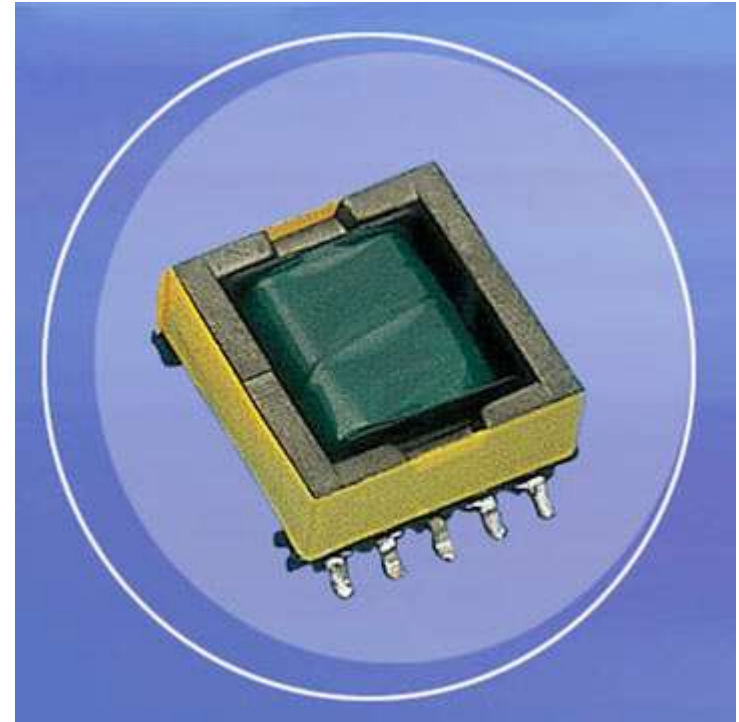
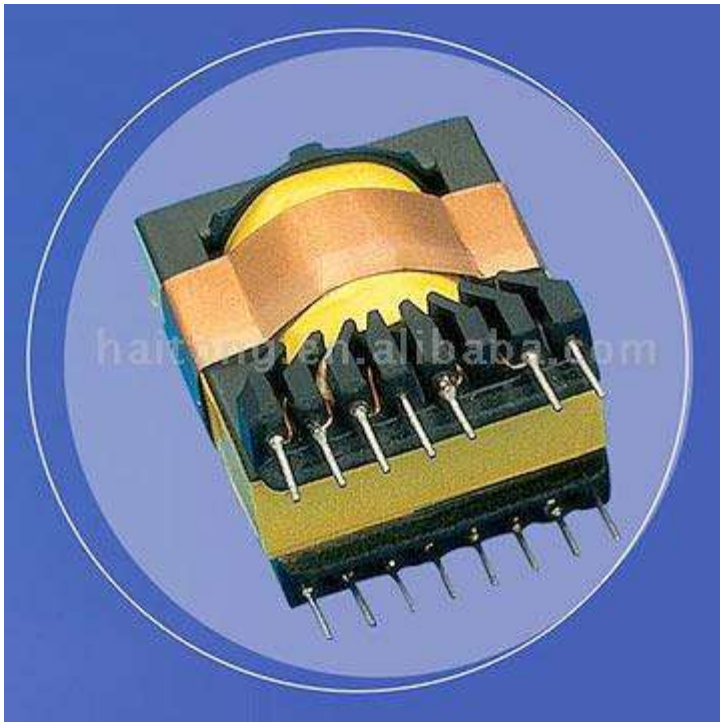

# Tipos e aplicações

**Transformadores para alta frequência:**

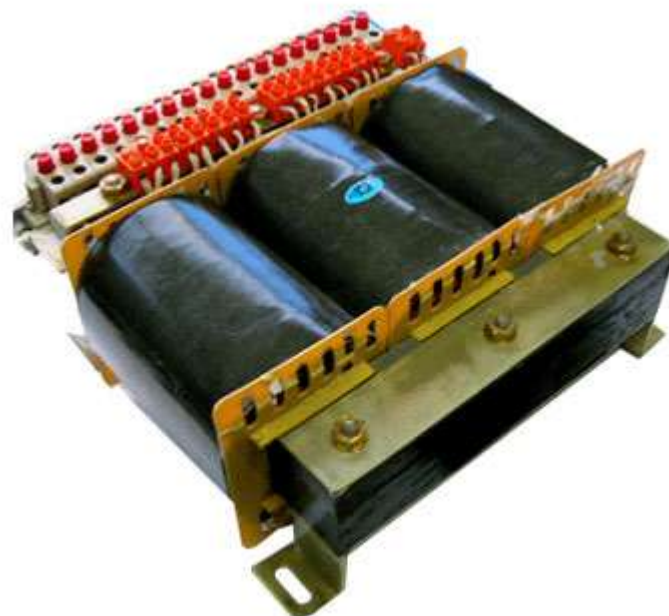

# Na próxima aula

## Capítulo 21: Transformadores

1. Projeto de transformadores.

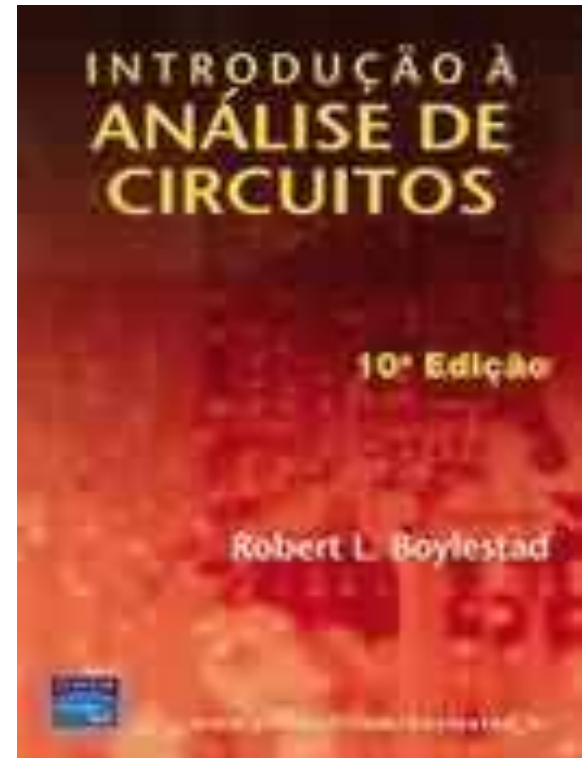

[www.cefetsc.edu.br/~petry](http://www.cefetsc.edu.br/~petry)