

Centro Federal de Educação Tecnológica de Santa Catarina
Departamento Acadêmico de Eletrônica
Retificadores

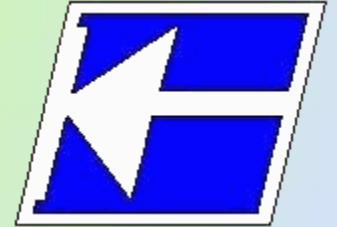

Diodos e dispositivos especiais

Prof. Clóvis Antônio Petry.

Florianópolis, outubro de 2008.

Bibliografia para esta aula

1. Diodos e dispositivos especiais – Parte 1.

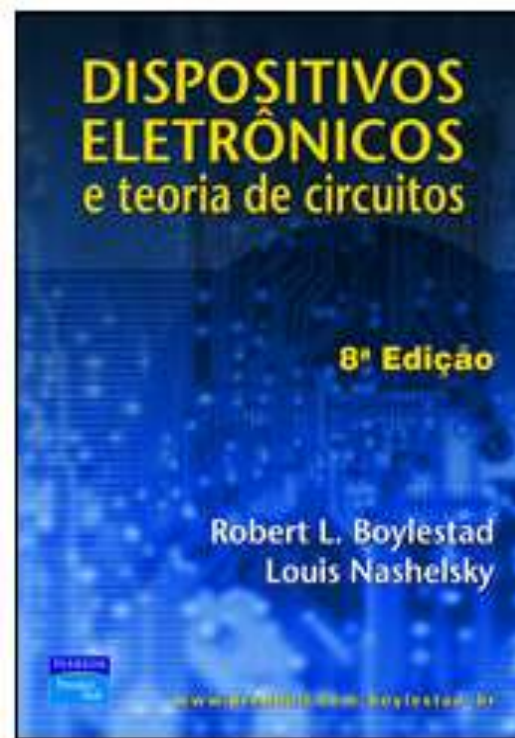

www.cefetsc.edu.br/~petry

Nesta aula

Seqüência de conteúdos:

1. Parte A – Resistores:

- Resistores;
- Termistores;
- LDRs;
- Varistores;

2. Parte B – Capacitores:

- Capacitores;

3. Parte C – Diodos:

- Zener;
- Diodos de barreira Schottky;
- Varicap;
- Diodos túnel;
- Diodos Shockley;
- Diac;
- Retificador controlado de silício (SCR);
- Triac.

Nesta aula

Seqüência de conteúdos:

4. Parte C – Diodos:
 - LEDs;
 - Fotodiodos;
5. Parte D – Transistores:
 - Fototransistores;
 - Optoacopladores;
6. Parte E – Outros dispositivos:
 - Células solares.
7. Parte F – Semicondutores de Carbetto de Silício (Silicon Carbide).

Parte A

Resistores

Resistores

Resistência depende de:

- Material;
- Comprimento;
- Área da seção reta;
- Temperatura.

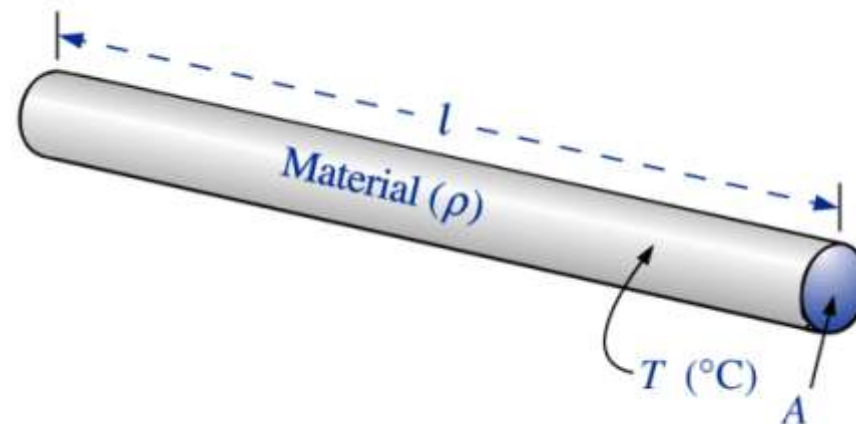

Resistores

Tipos de resistores:

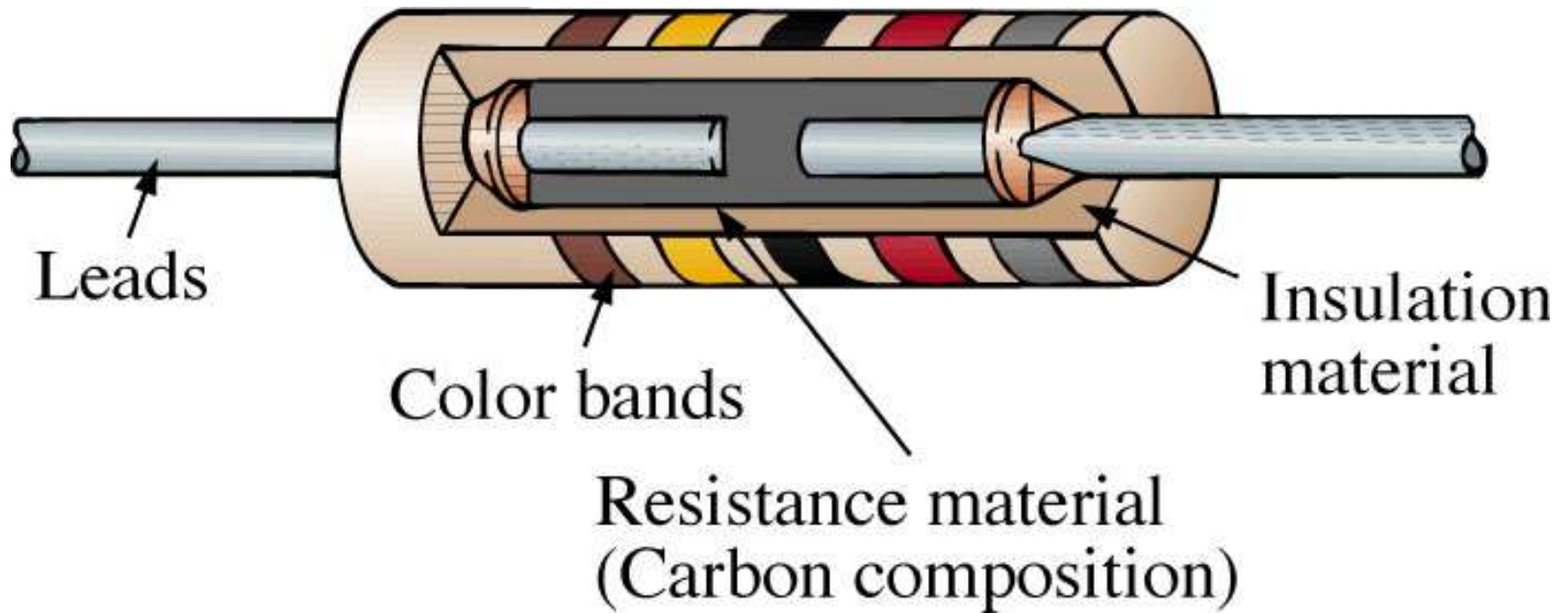

Resistor fixo de carbono.

Resistores

Tipos de resistores:

Resistores fixos de carbono com potências diferentes.



2 W



1 W



$\frac{1}{2}$ W



$\frac{1}{4}$ W



$\frac{1}{8}$ W

Resistores

Tipos de resistores:

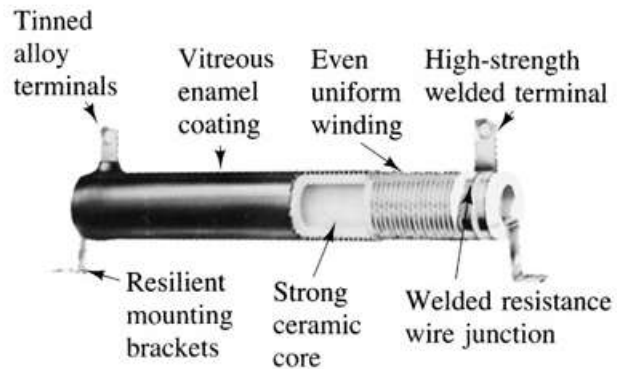

(a) Vitreous-enameled wire-wound resistor
App: All types of equipment



(b) High-voltage cermet film resistors (on a high grade ceramic body).
App: For high-voltage applications up to 10 kV requiring high levels of stability.



(c) Metal-film precision resistors
App: Where high stability, low temperature coefficient, and low noise level desired

Resistores de potência de fio.

Resistores para altas tensões.

Resistores de precisão de filme metálico.

Resistores

Tipos de resistores:



Resistores de potência.

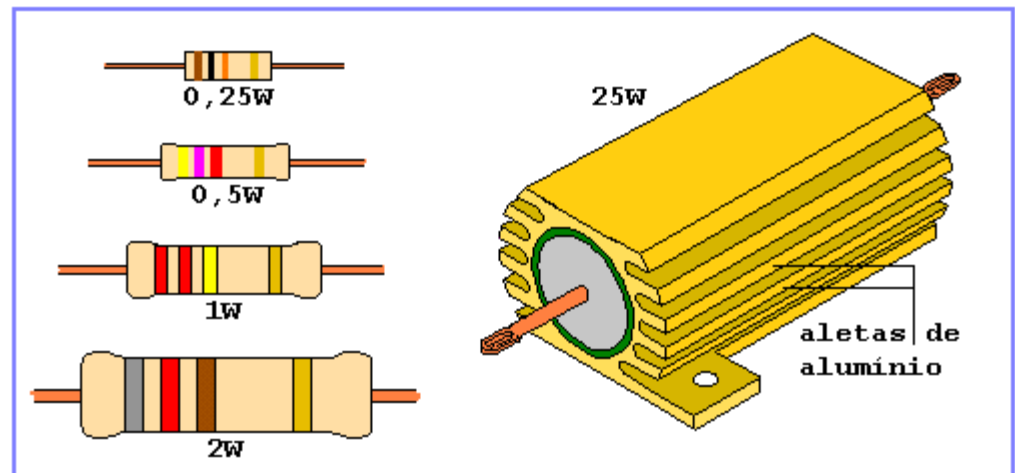
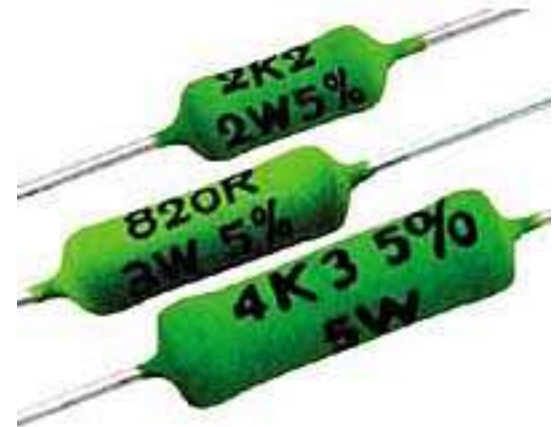

Resistores

Tipos de resistores:

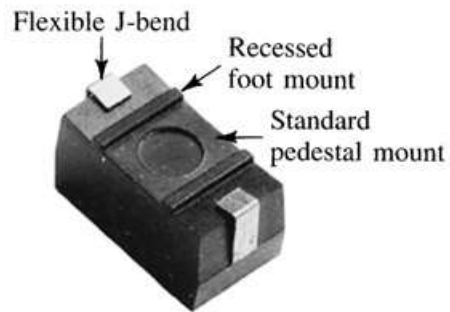

- (a) Surface mount power resistor ideal for printed circuit boards. Patented J-bends eliminate need for solder connections. (0.8 W to 3 W in wire-wound, film, or power film construction)

Resistores de
potência de fio.



- (b) Precision power wire-wound resistors with ratings as high as 2 W and tolerances as low as 0.05%. Temperature coefficients as low as 20 ppm/°C are also available.

Resistores de
precisão de fio.

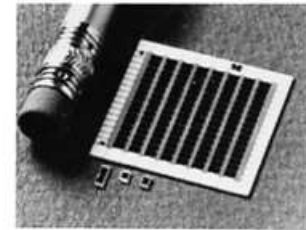

- (c) Thick-film chip resistors for design flexibility with hybrid circuitry. Pre-tinned, gold or silver electrodes available. Operating temperature range -55°C to +150°C.

Resistores de
filme em chip.

Resistores

Tipos de resistores:

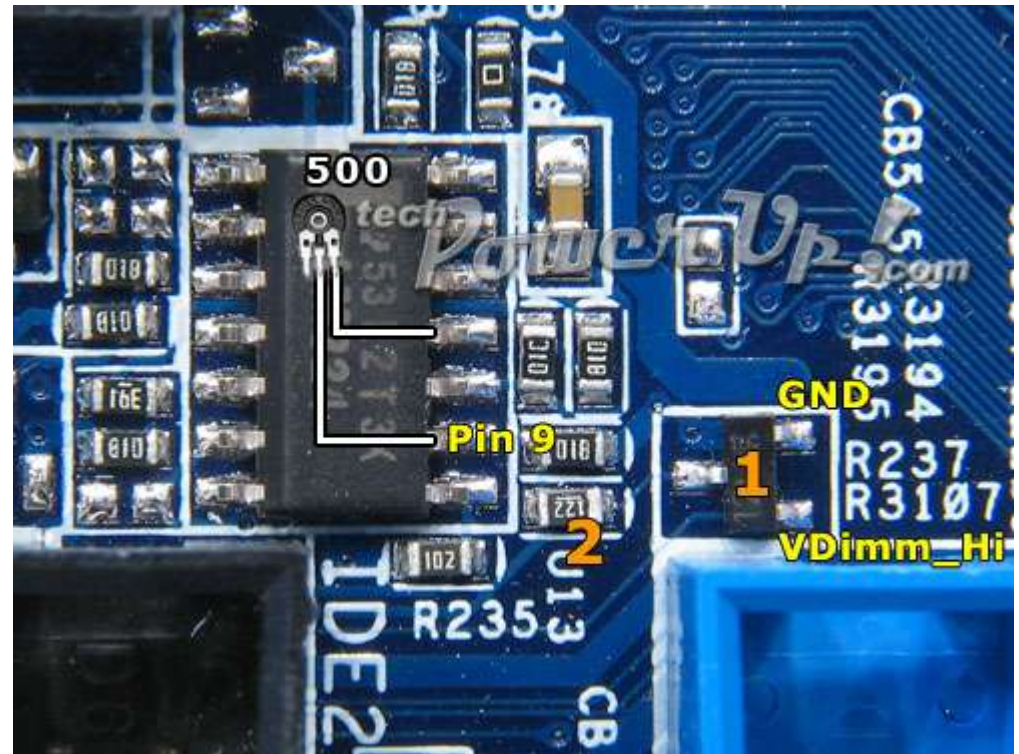
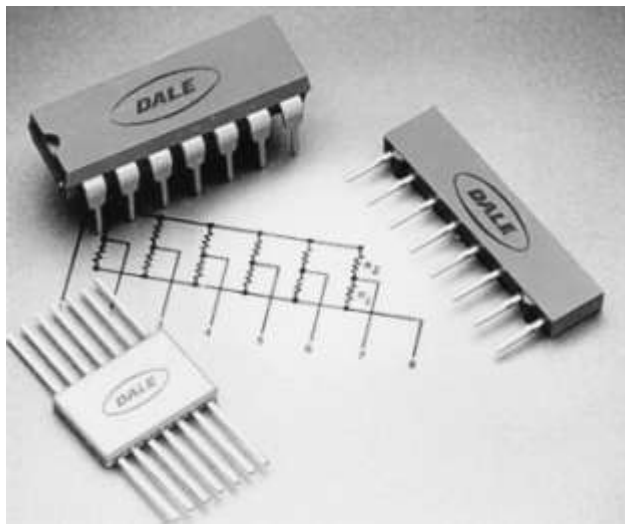

Resistores

Tipos de resistores:

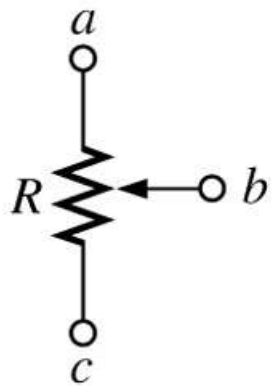

(a)

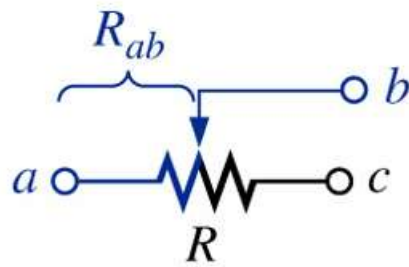

(b)

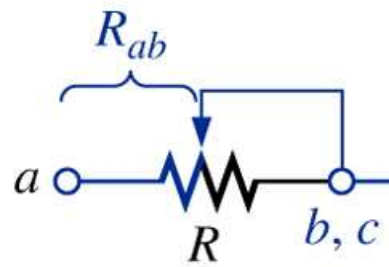

(c)



(d)

Resistores
variáveis e
ajustáveis.



Trimpots e
potenciômetros.

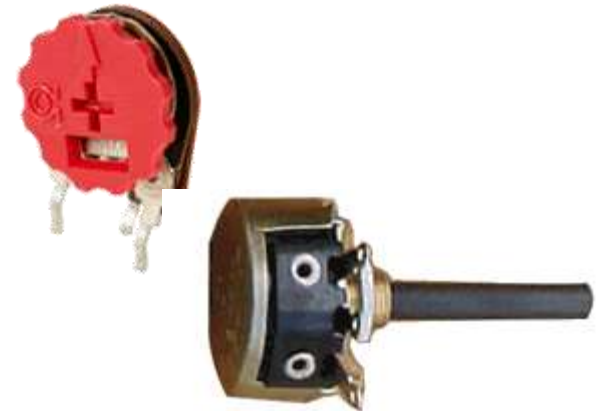

Resistores

Tipos de resistores:

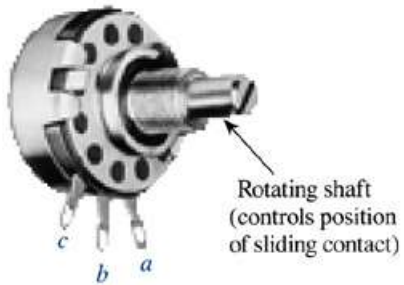

(a) External view

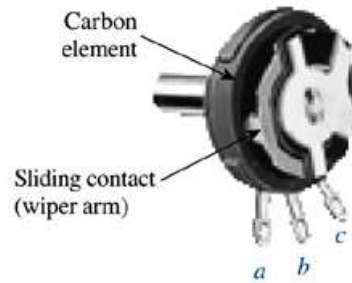

(b) Internal view

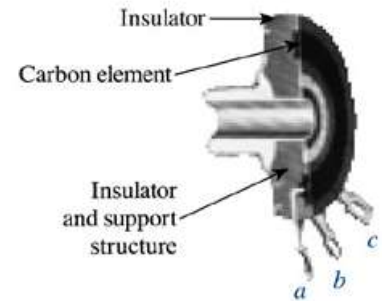

(c) Carbon element



Resistores

Tipos de resistores:

Resistores variáveis e ajustáveis.

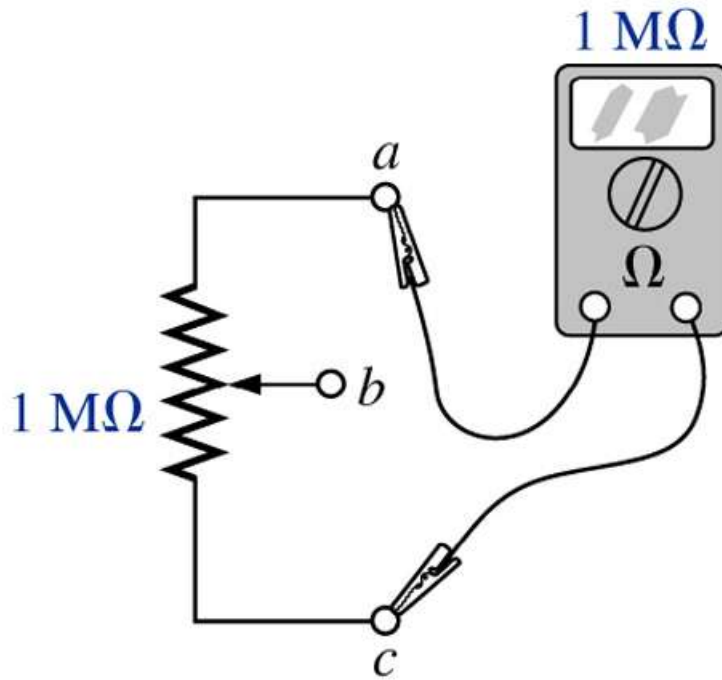

(a)

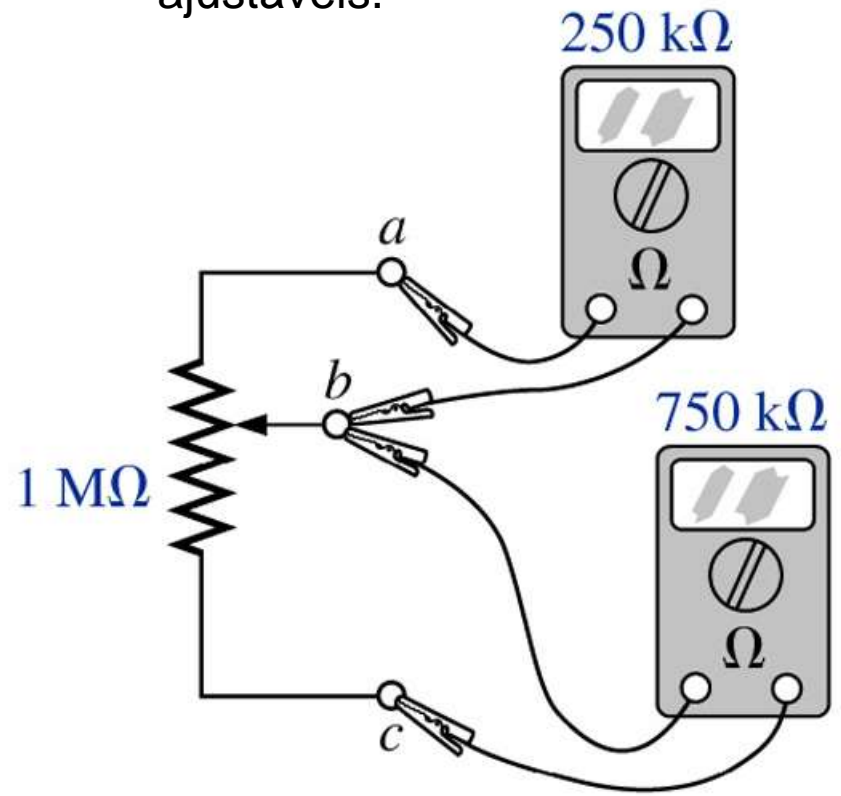

(b)

Resistores

Tipos de resistores:

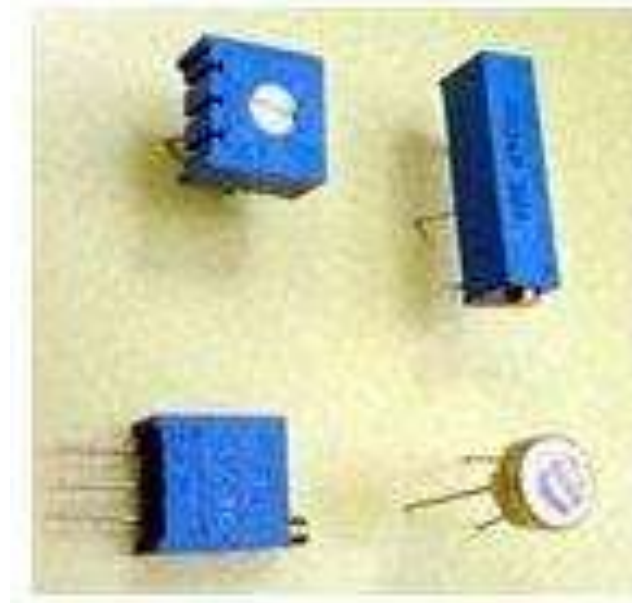
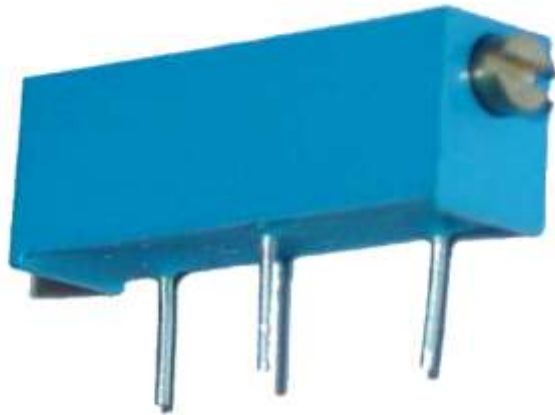

Resistores
variáveis e
ajustáveis.

Resistores

Tipos de resistores:

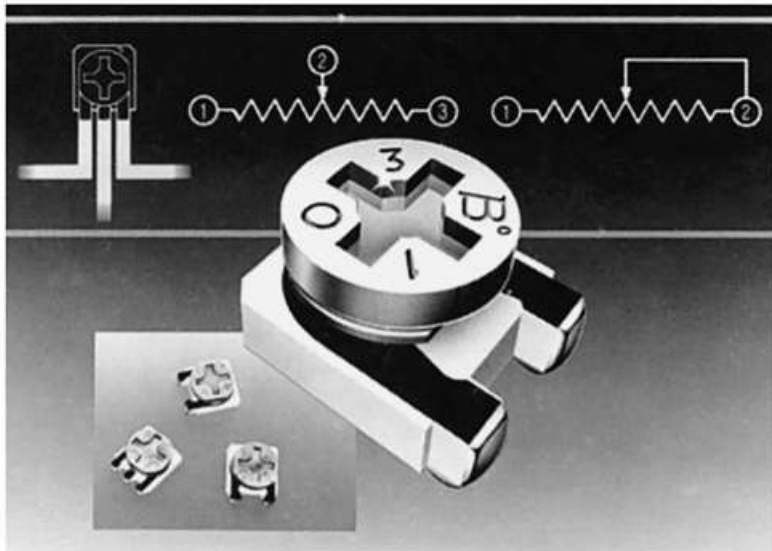

(a)

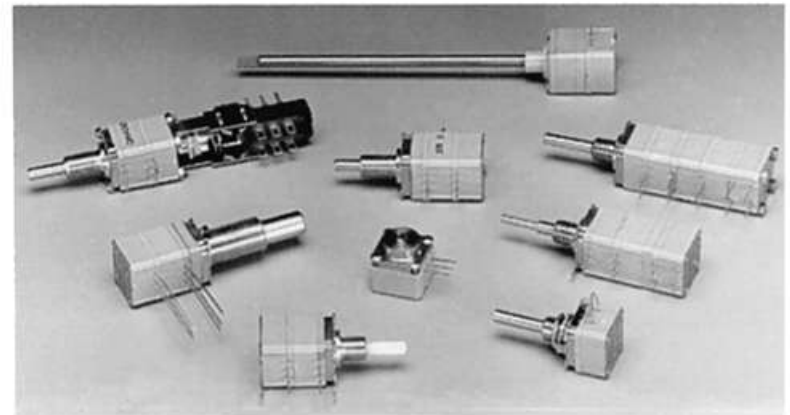

(b)

Potenciômetros
de precisão ou
multivoltas.

Termistores

Termistor:

- Resistor cuja resistência é sensível à variação da temperatura.

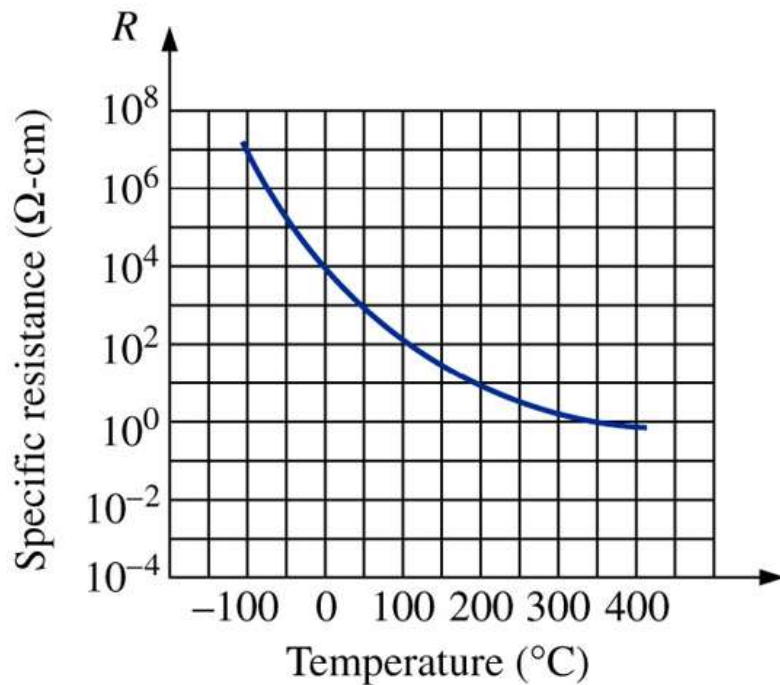

(a)



(b)

Termistores

Termistor NTC:

- Coeficiente negativo de temperatura;
- Resistência diminui com o aumento da temperatura.

Termistor PTC:

- Coeficiente positivo de temperatura;
- Resistência aumenta com o aumento da temperatura.

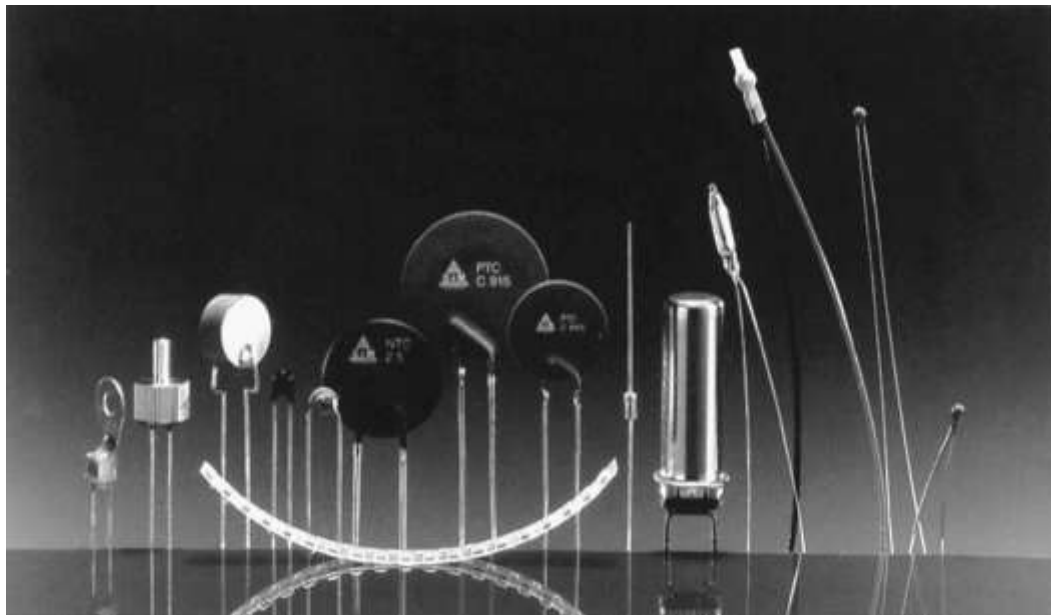

Célula fotocondutora ou LDR

LDR (Light dependent resistor) ou célula fotocondutora:

- A resistência é determinada pela intensidade da luz incidente em sua superfície.

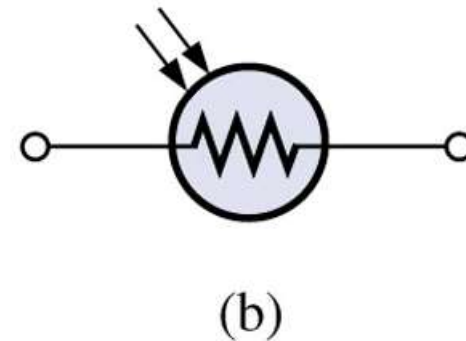
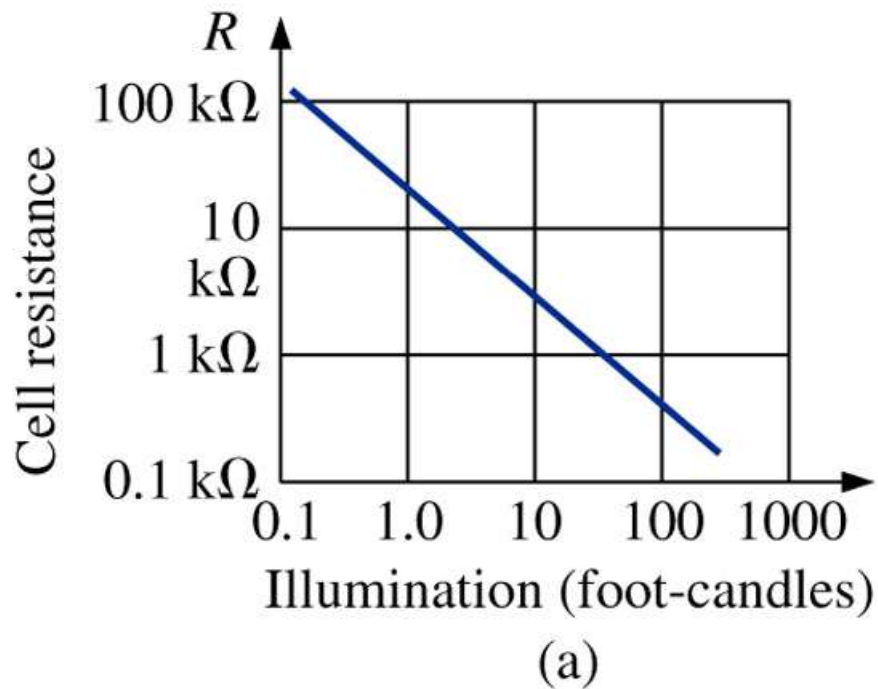

Célula fotocondutora ou LDR

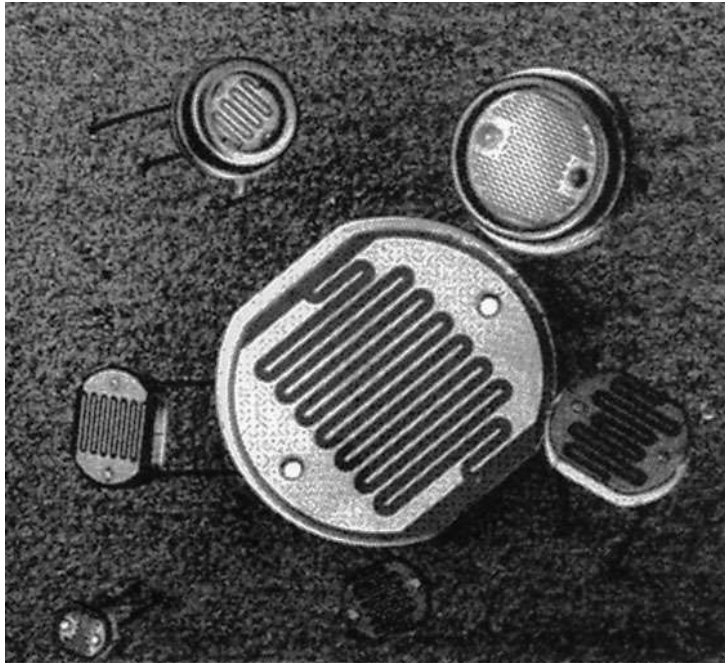

Varistores

Varistores:

- São resistores não-lineares, cuja resistência depende da tensão aplicada, usados para suprimir transientes de alta tensão.

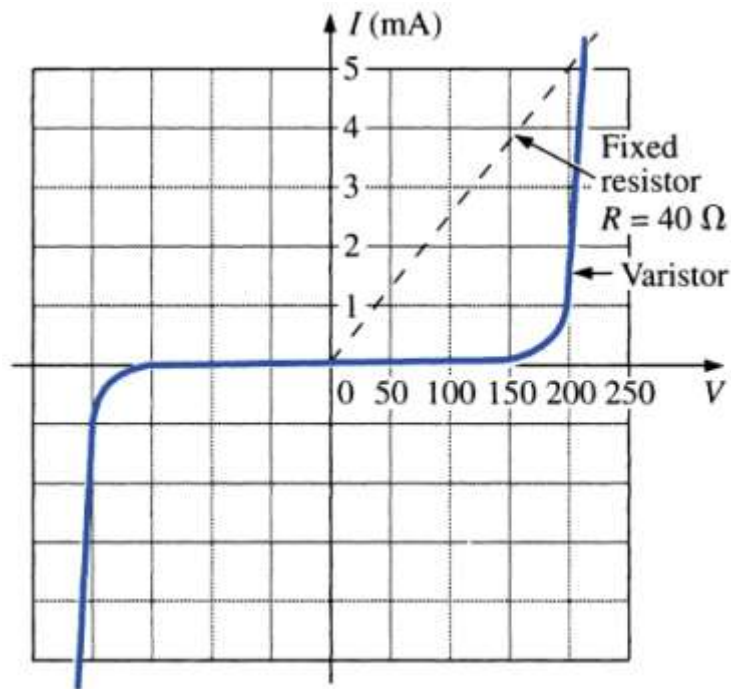

(a)

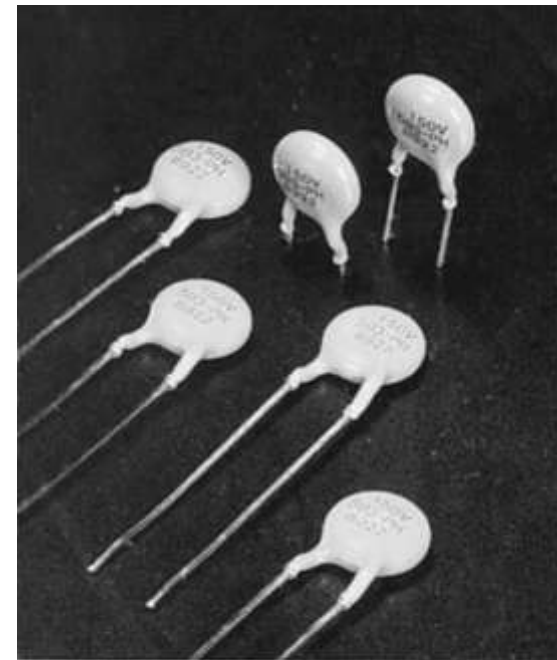

(b)

Resistores e similares

Testando resistores e similares:

Usando multímetro (Ω):

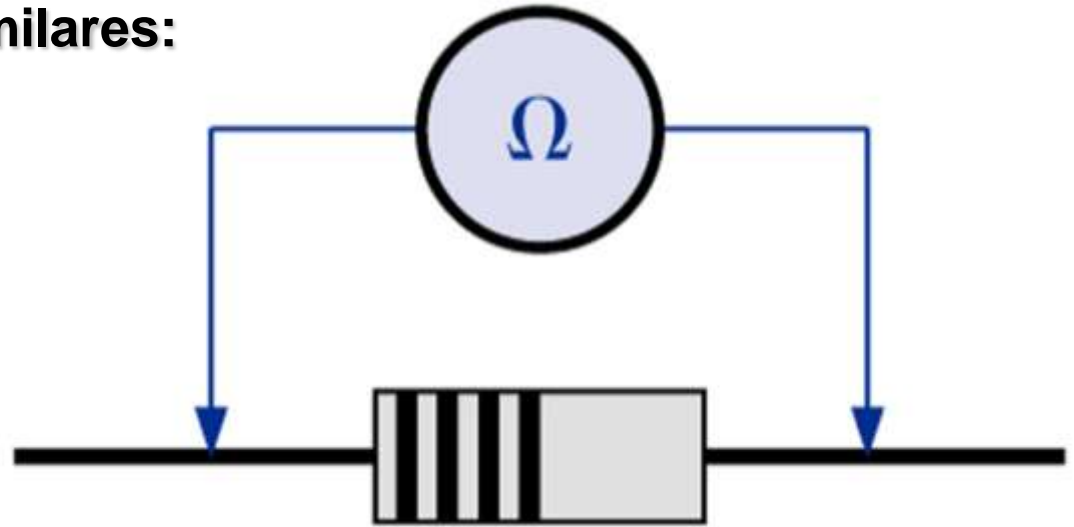

Aplicando a Lei de Ohm:

$$R = \frac{V}{I}$$

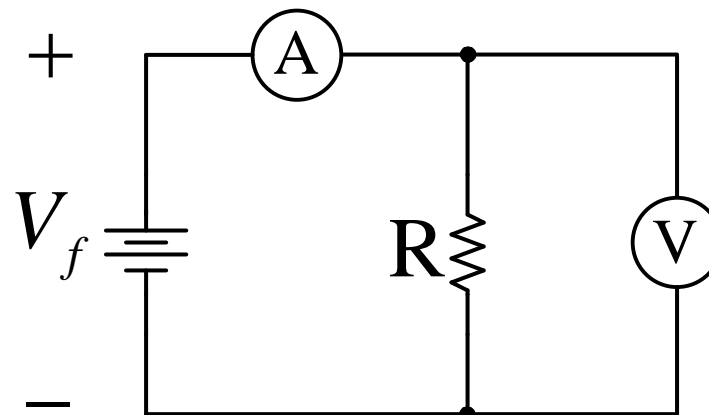

Parte B

Capacitores

Capacitores

Capacitância depende de:

- Dielétrico (permissividade);
- Área das placas;
- Distância entre as placas.

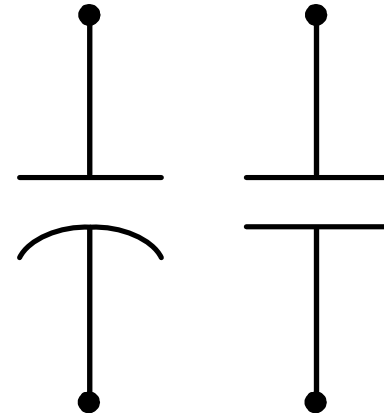
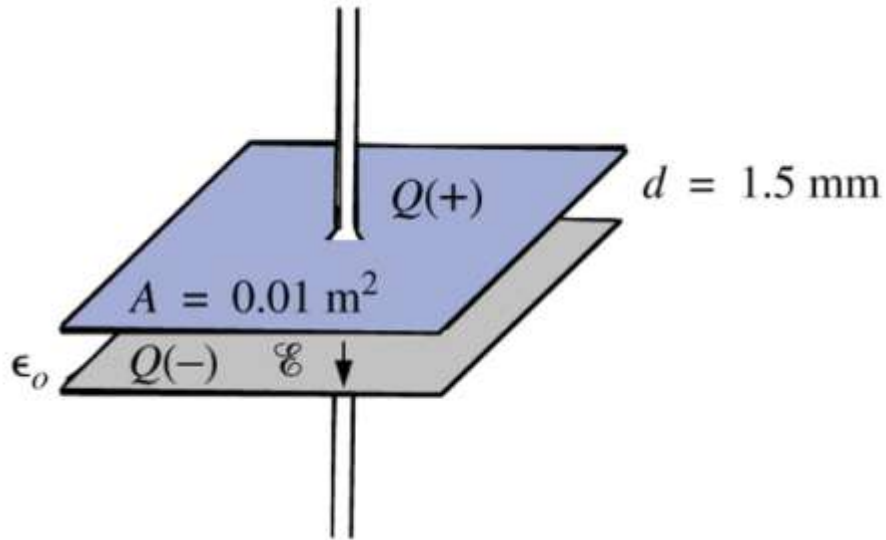

Capacitores

Tipos de capacitores:

Capacitores fixos de mica.

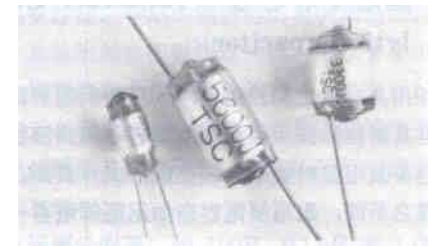
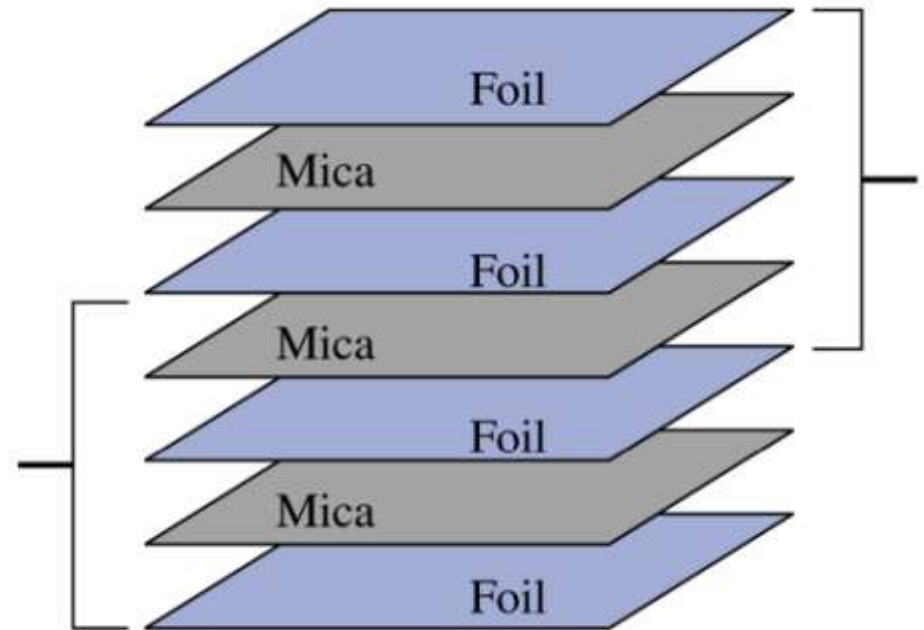

Capacitores

Tipos de capacitores:



Capacitores de disco de cerâmica.

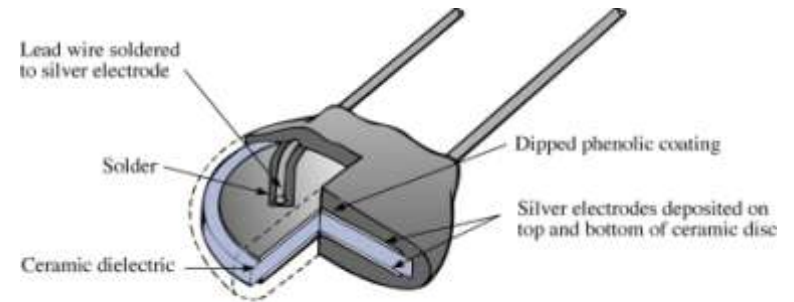

(b)

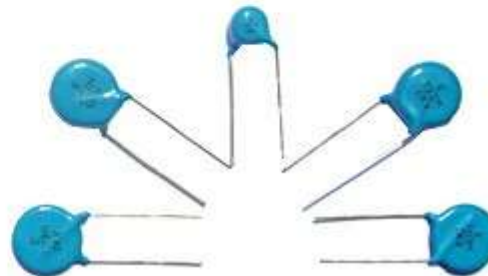
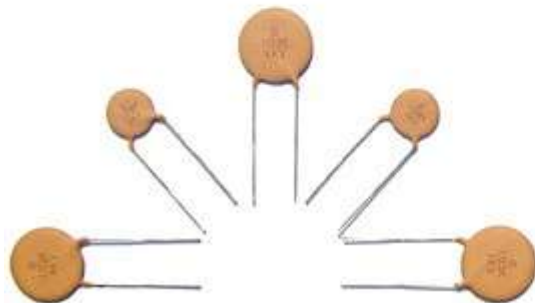
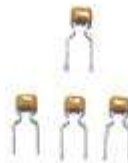

Capacitores

Tipos de capacitores:



(a)

Capacitores integrados.

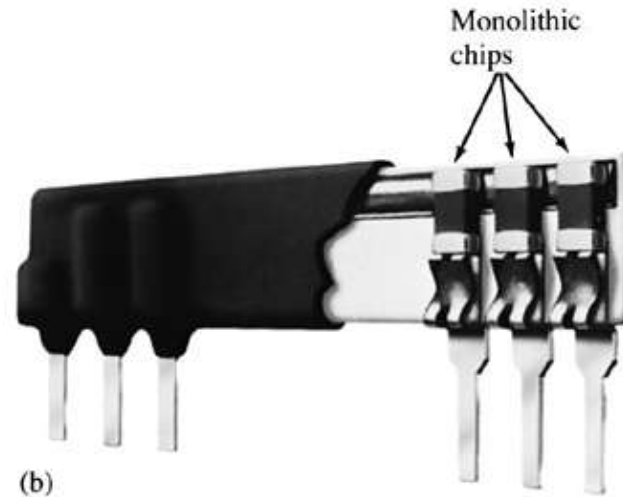

(b)

Capacitores

Tipos de capacitores:

Capacitores eletrolíticos.

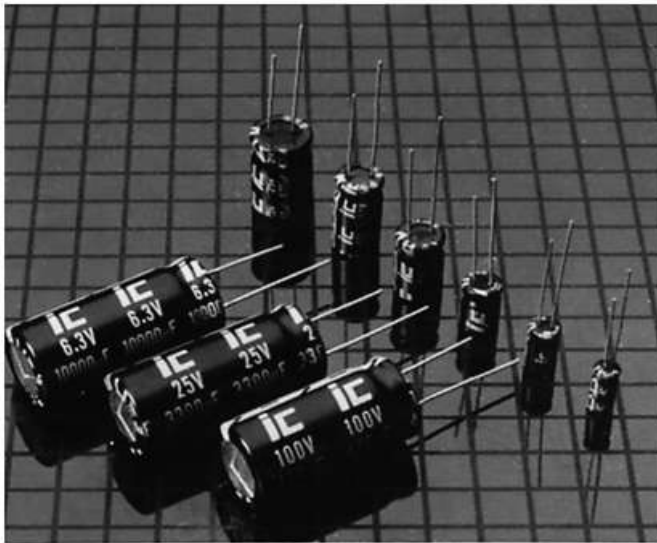

(a)

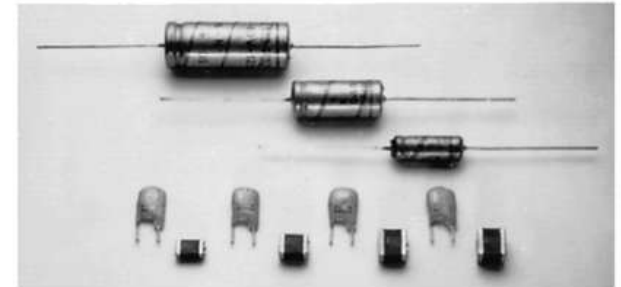

(b)

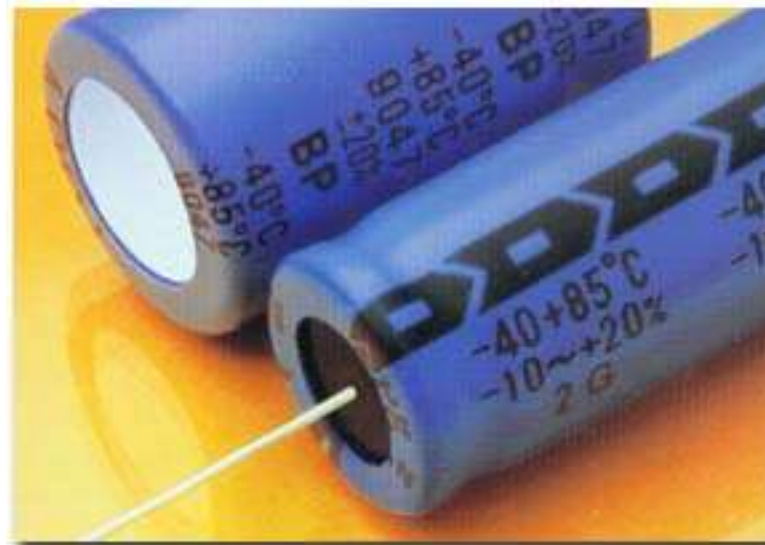

Capacitores

Tipos de capacitores:

Capacitores de tântalo.

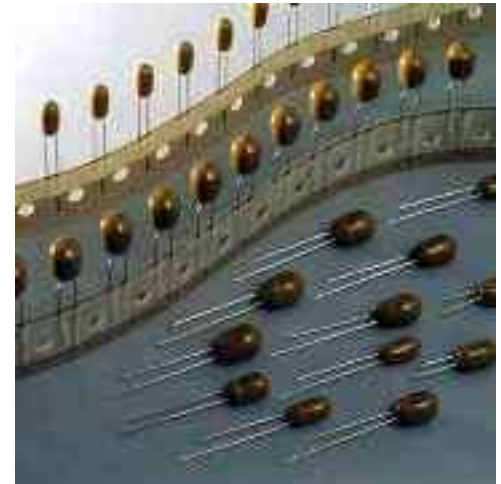
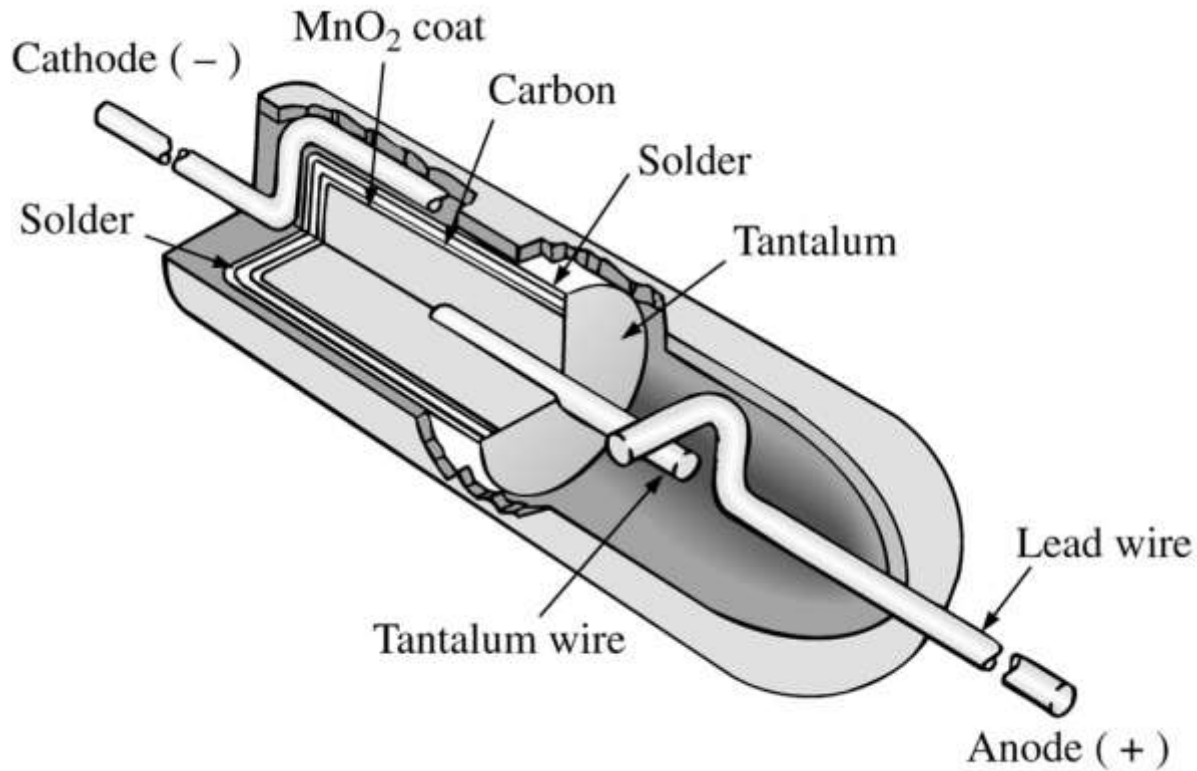

Capacitores

Tipos de capacitores:

Capacitores de filme de poliéster.

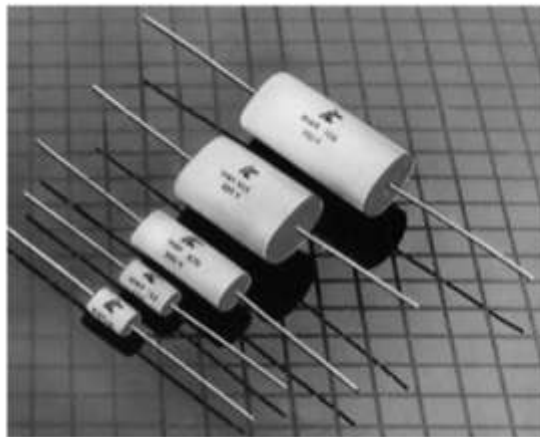
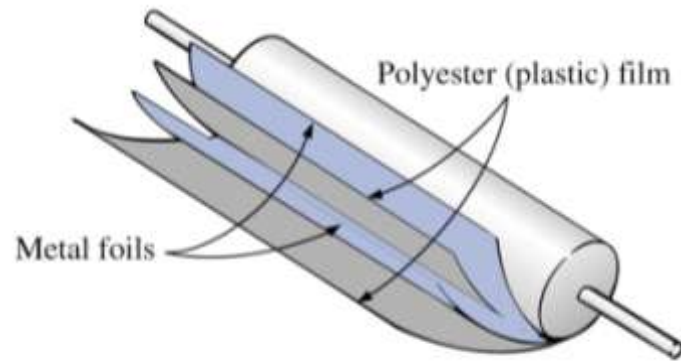

(a)

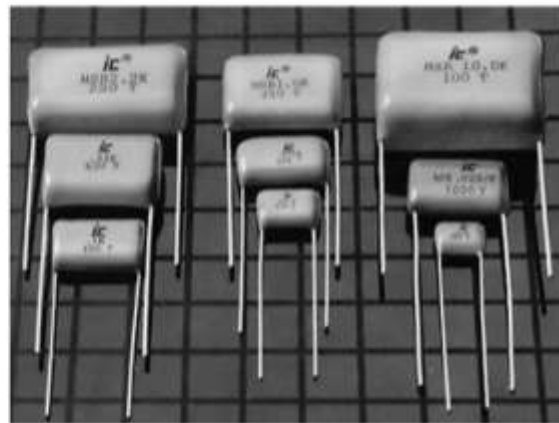

(b)

Capacitores

Tipos de capacitores:



Capacitores variáveis e ajustáveis.

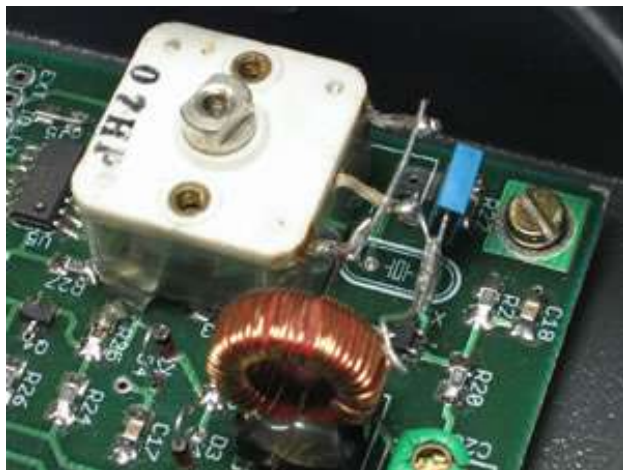

Capacitores

Tipos de capacitores:

Super capacitores



Small capacitance	3F, 2.3V – 300F, 2.3V	back-up power, on-board UPS, etc.
Medium capacitance	300F, 2.3V – 5000F, 2.7V	peak power, UPS, etc.
Large capacitance	5000F, 2.7V – 80.000F, 1.8 V	peak power, low maintenance energy storage, etc.
Supercapacitor modules	5V- 700V, capacitance on request.	Higher voltage applications



Capacitores

Tipos de capacitores, resumen:

Type: Miniature Axial Electrolytic
Typical Values: 0.1 μ F to 15,000 μ F
Typical Voltage Range: 5 V to 450 V
Capacitor tolerance: \pm 20%
Applications: Polarized, used in DC power supplies, bypass filters, DC blocking.



Type: Miniature Radial Electrolyte
Typical Values: 0.1 μ F to 15,000 μ F
Typical Voltage Range: 5 V to 450 V
Capacitor tolerance: \pm 20%
Applications: Polarized, used in DC power supplies, bypass filters, DC blocking.



Type: Ceramic Disc
Typical Values: 10 pF to 0.047 μ F
Typical Voltage Range: 100 V to 6 kV
Capacitor tolerance: \pm 5%, \pm 10%
Applications: Non-polarized, NPO type, stable for a wide range of temperatures. Used in oscillators, noise filters, circuit coupling, tank circuits.



Type: Dipped Tantalum (solid and wet)
Typical Values: 0.047 μ F to 470 μ F
Typical Voltage Range: 6.3 V to 50 V
Capacitor tolerance: \pm 10%, \pm 20%
Applications: Polarized, low leakage current, used in power supplies, high frequency noise filters, bypass filter.



Type: Surface Mount Type (SMT)
Typical Values: 10 pF to 10 μ F
Typical Voltage Range: 6.3 V to 16 V
Capacitor tolerance: \pm 10%
Applications: Polarized and non-polarized, used in all types of circuits, requires a minimum amount of PC board real estate.



Type: Silver Mica
Typical Value: 10 pF to 0.001 μ F
Typical Voltage Range: 50 V to 500 V
Capacitor tolerance: \pm 5%
Applications: Non-polarized, used in oscillators, in circuits that require a stable component over a range of temperatures and voltages.



Type: Mylar Paper
Typical Value: 0.001 μ F to 0.68 μ F
Typical Voltage Range: 50 V to 600 V
Capacitor tolerance: \pm 22%
Applications: Non-polarized, used in all types of circuits, moisture resistant.



Type: AC/DC Motor Run
Typical Value: 0.25 μ F to 1200 μ F
Typical Voltage Range: 240 V to 660 V
Capacitor tolerance: \pm 10%
Applications: Non-polarized, used in motor run-start, high-intensity lighting supplies, AC noise filtering.



Type: Trimmer Variable
Typical Value: 1.5 pF to 600 pF
Typical Voltage Range: 5 V to 100 V
Capacitor tolerance: \pm 10%
Applications: Non-polarized, used in oscillators, tuning circuits, AC filters.



Type: Tuning variable
Typical Value: 10 pF to 600 pF
Typical Voltage Range: 5 V to 100 V
Capacitor tolerance: \pm 10%
Applications: Non-polarized, used in oscillators, radio tuning circuit.



Capacitores

Tipos de capacitores:

Type: Miniature Axial Electrolytic
Typical Values: 0.1 μF to 15,000 μF
Typical Voltage Range: 5 V to 450 V
Capacitor tolerance: $\pm 20\%$
Applications: Polarized, used in DC power supplies, bypass filters, DC blocking.

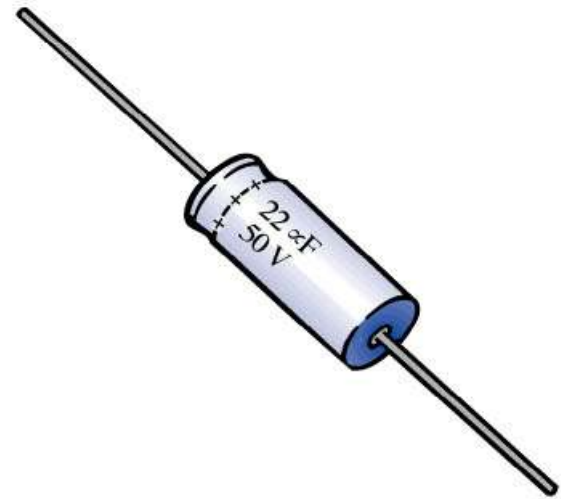

Capacitores

Tipos de capacitores:

Type: Miniature Radial Electrolyte

Typical Values: 0.1 μF to 15,000 μF

Typical Voltage Range: 5 V to 450 V

Capacitor tolerance: $\pm 20\%$

Applications: Polarized, used in DC power supplies, bypass filters, DC blocking.



Capacitores

Tipos de capacitores:

Type: Ceramic Disc

Typical Values: 10 pF to 0.047 μ F

Typical Voltage Range: 100 V to 6 kV

Capacitor tolerance: $\pm 5\%$, $\pm 10\%$

Applications: Non-polarized, NPO type, stable for a wide range of temperatures. Used in oscillators, noise filters, circuit coupling, tank circuits.

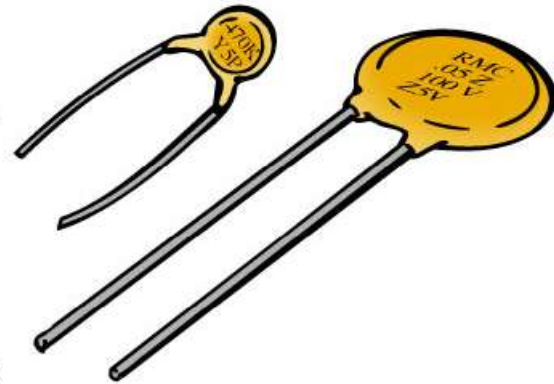

Capacitores

Tipos de capacitores:

Type: Dipped Tantalum (solid and wet)

Typical Values: 0.047 μ F to 470 μ F

Typical Voltage Range: 6.3 V to 50 V

Capacitor tolerance: $\pm 10\%$, $\pm 20\%$

Applications: Polarized, low leakage current, used in power supplies, high frequency noise filters, bypass filter.

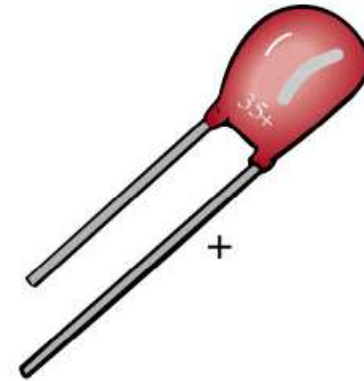

Capacitores

Tipos de capacitores:

Type: Surface Mount Type (SMT)

Typical Values: 10 pF to 10 μ F

Typical Voltage Range: 6.3 V to 16 V

Capacitor tolerance: $\pm 10\%$

Applications: Polarized and non-polarized, used in all types of circuits, requires a minimum amount of PC board real estate.

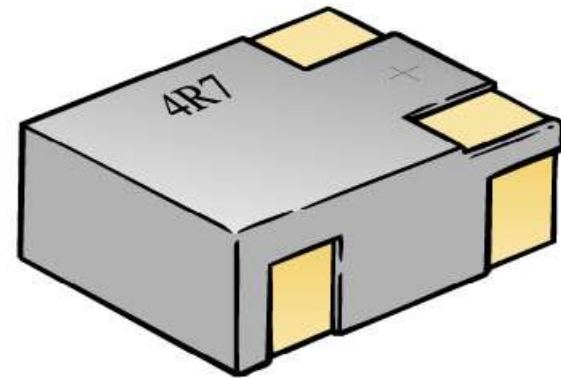

Capacitores

Tipos de capacitores:

Type: Silver Mica

Typical Value: 10 pF to 0.001 μ F

Typical Voltage Range: 50 V to 500 V

Capacitor tolerance: $\pm 5\%$

Applications: Non-polarized, used in oscillators, in circuits that require a stable component over a range of temperatures and voltages.

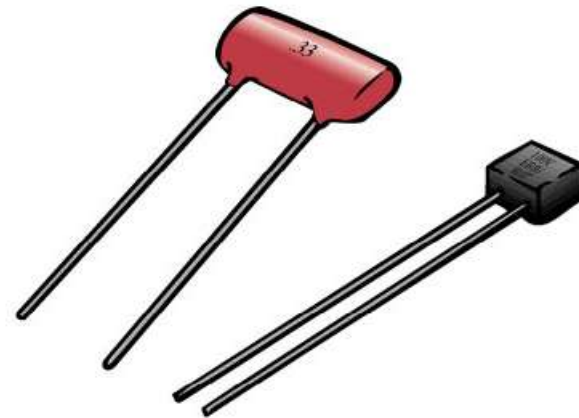

Capacitores

Tipos de capacitores:

Type: Mylar Paper

Typical Value: 0.001 μF to 0.68 μF

Typical Voltage Range: 50 V to 600 V

Capacitor tolerance: $\pm 22\%$

Applications: Non-polarized, used in all types of circuits, moisture resistant.

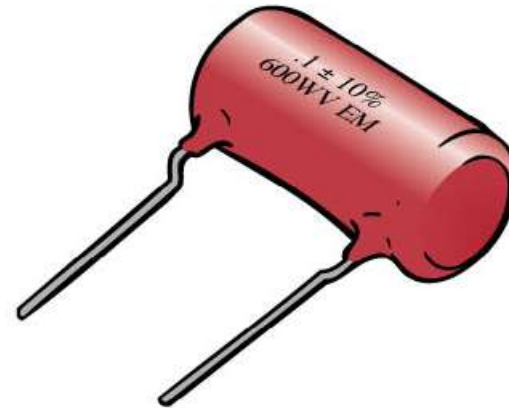

Capacitores

Tipos de capacitores:

Type: AC/DC Motor Run

Typical Value: 0.25 μ F to 1200 μ F

Typical Voltage Range: 240 V to 660 V

Capacitor tolerance: $\pm 10\%$

Applications: Non-polarized, used in motor run-start, high-intensity lighting supplies, AC noise filtering.



Capacitores

Tipos de capacitores:

Type: Trimmer Variable

Typical Value: 1.5 pF to 600 pF

Typical Voltage Range: 5 V to 100 V

Capacitor tolerance: $\pm 10\%$

Applications: Non-polarized, used in oscillators, tuning circuits, AC filters.



Capacitores

Tipos de capacitores:

Type: Tuning variable

Typical Value: 10 pF to 600 pF

Typical Voltage Range: 5 V to 100 V

Capacitor tolerance: $\pm 10\%$

Applications: Non-polarized, used in oscillators, radio tuning circuit.

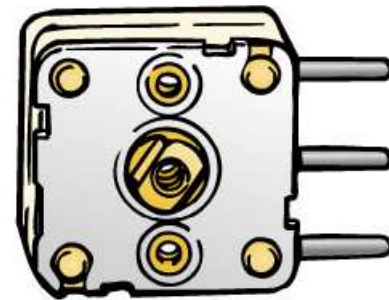

Capacitores

Testando capacitores:

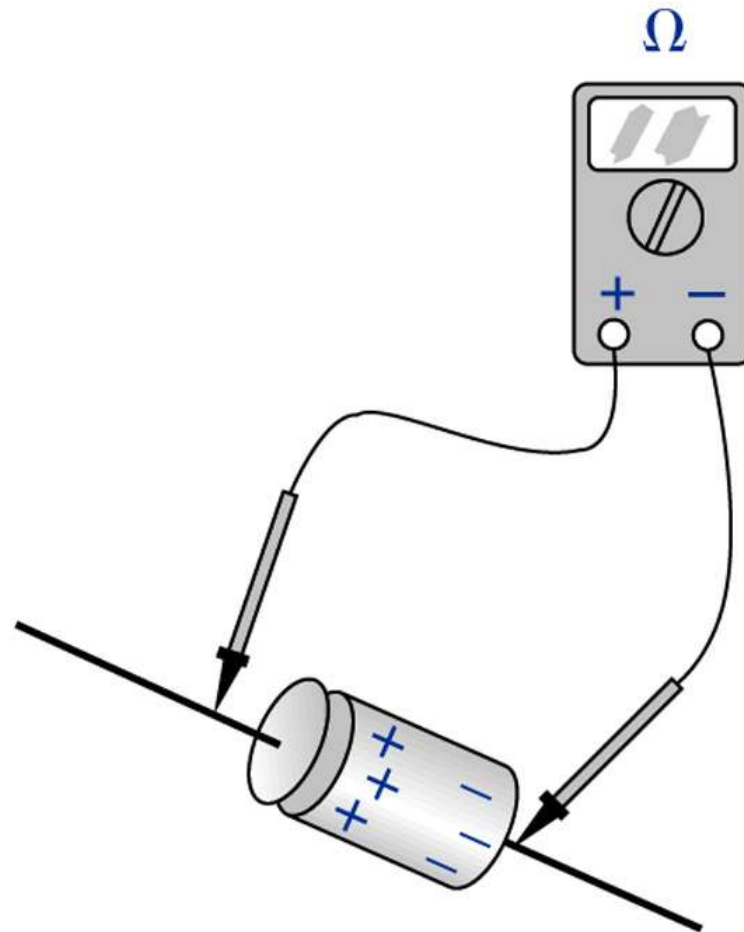

Diodos

Diodos zener

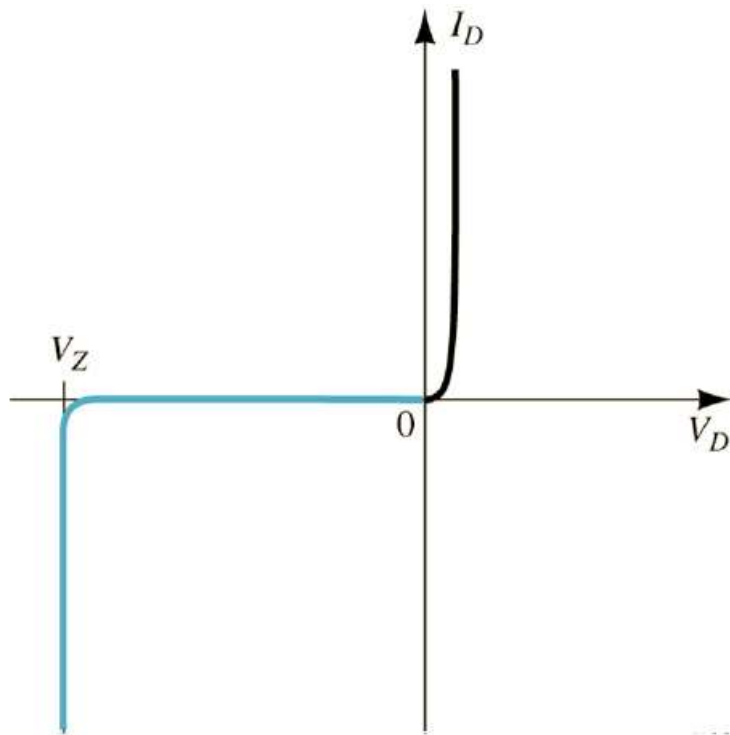

Curva I_D x V_D

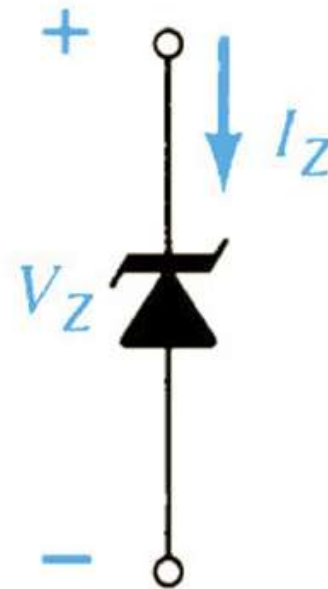

Diodo zener

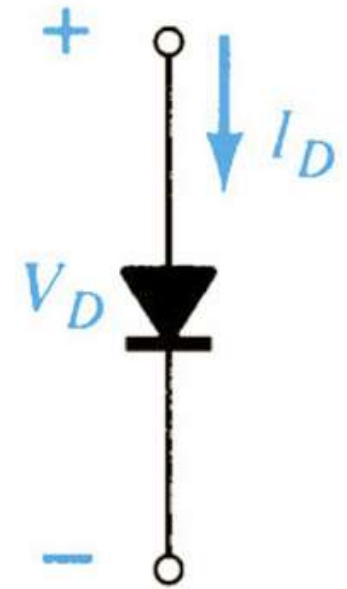

Diodo convencional

Diodos zener

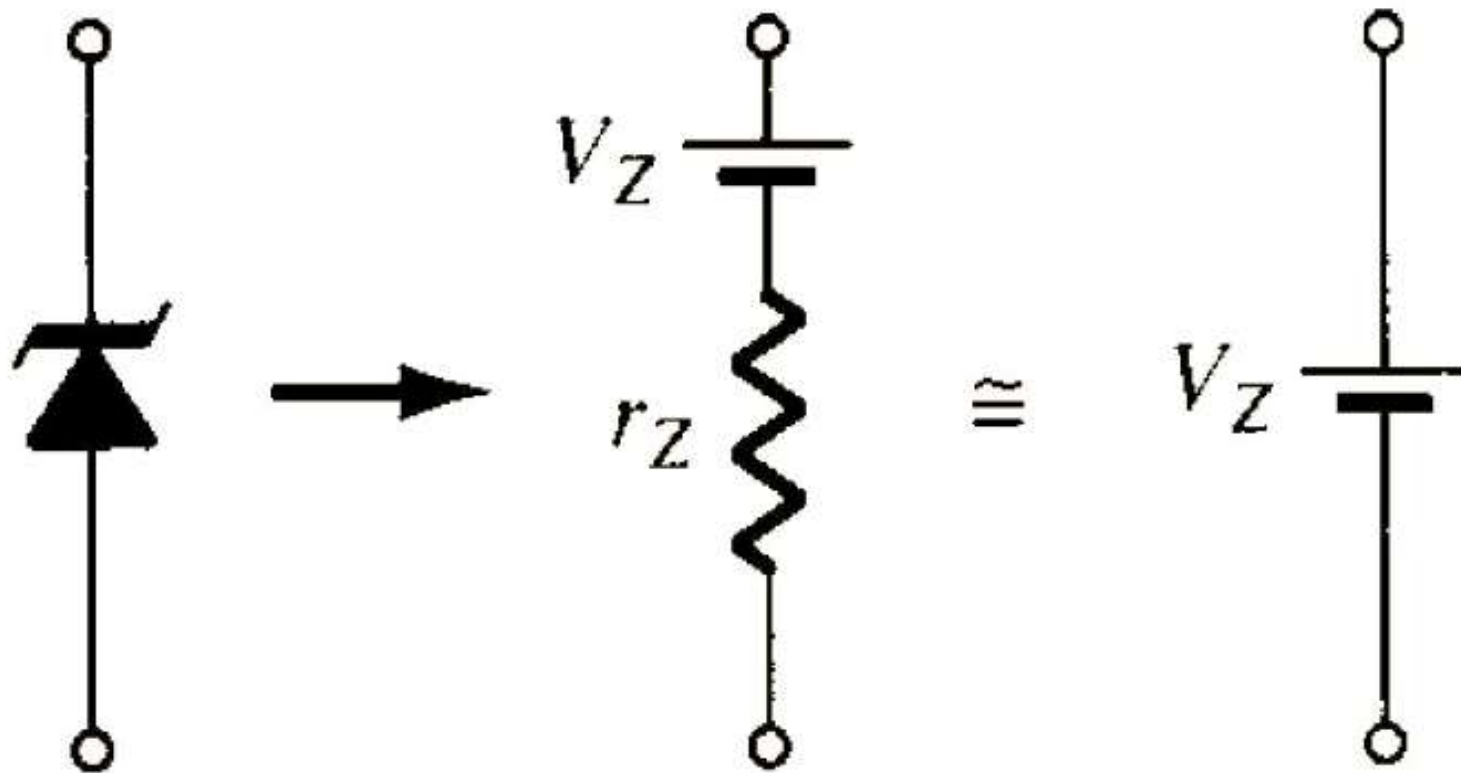

Circuitos equivalentes do diodo zener

Diodos zener

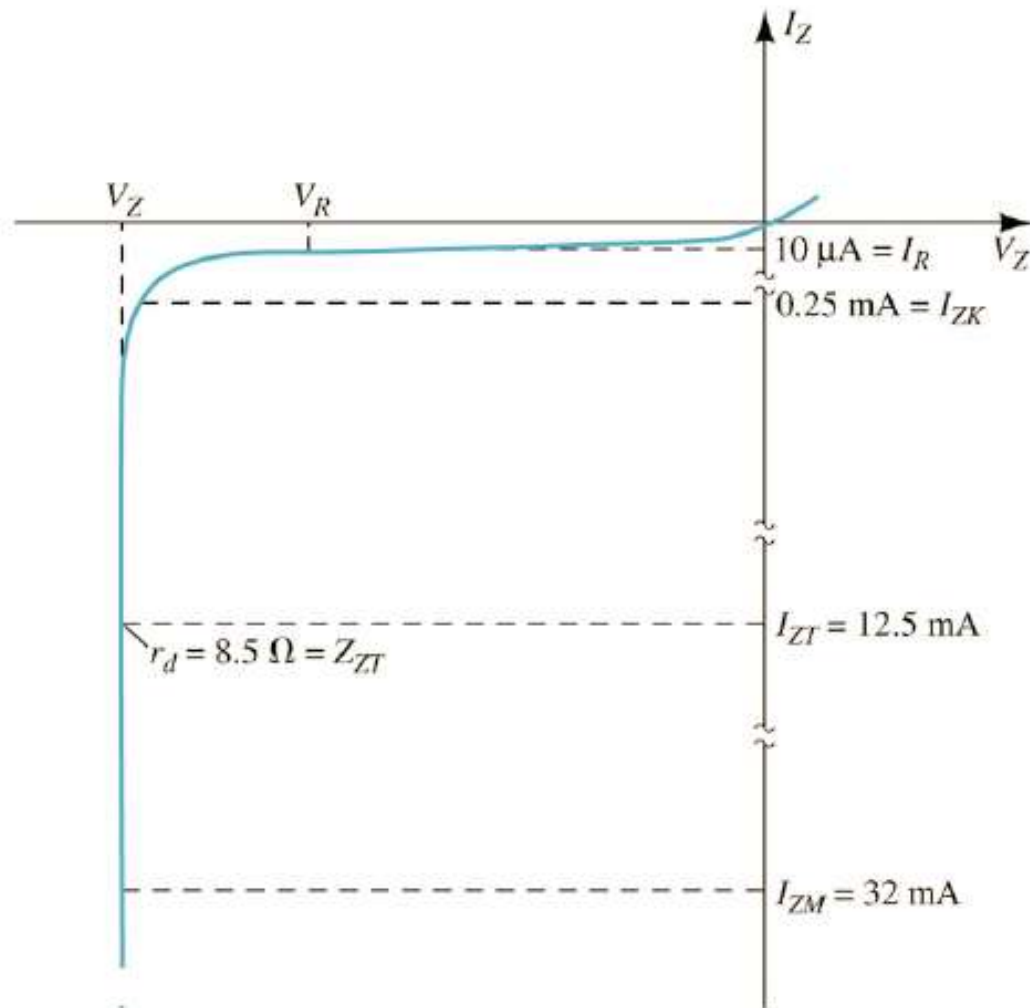

Curva $I_D \times V_D$

Diodos zener

Aspectos de diodos zener:

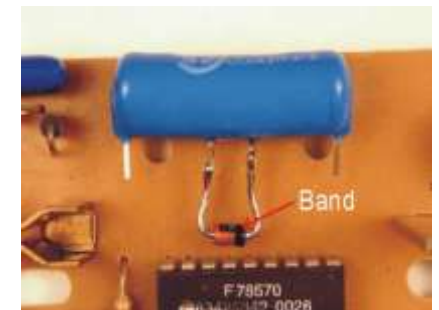
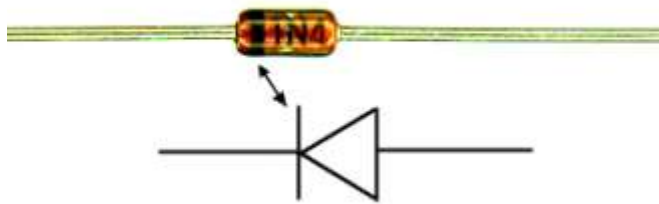
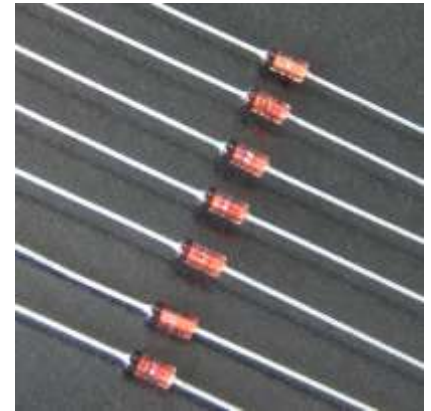
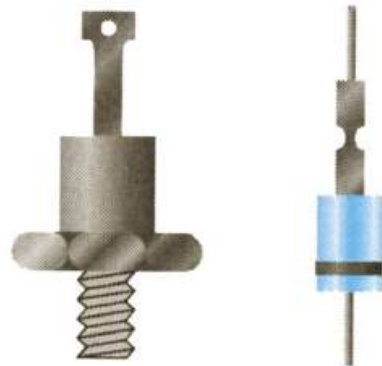
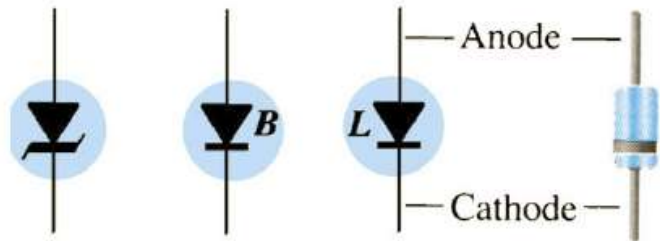

Diodos de barreira Schottky

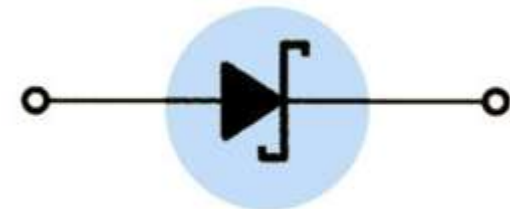
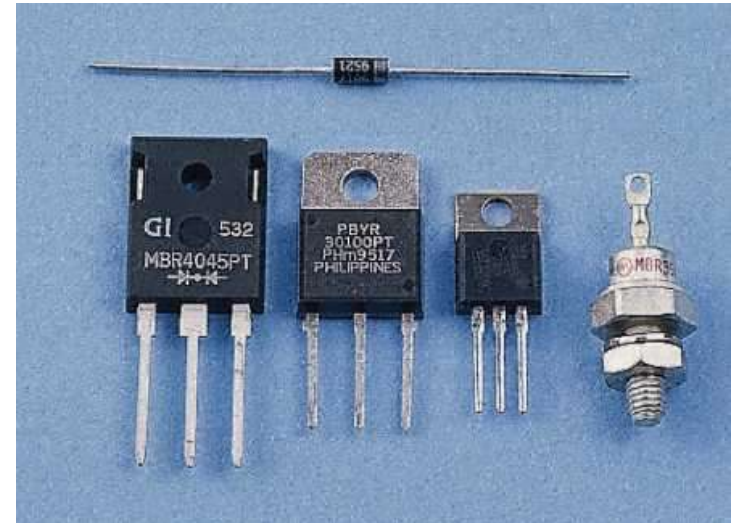
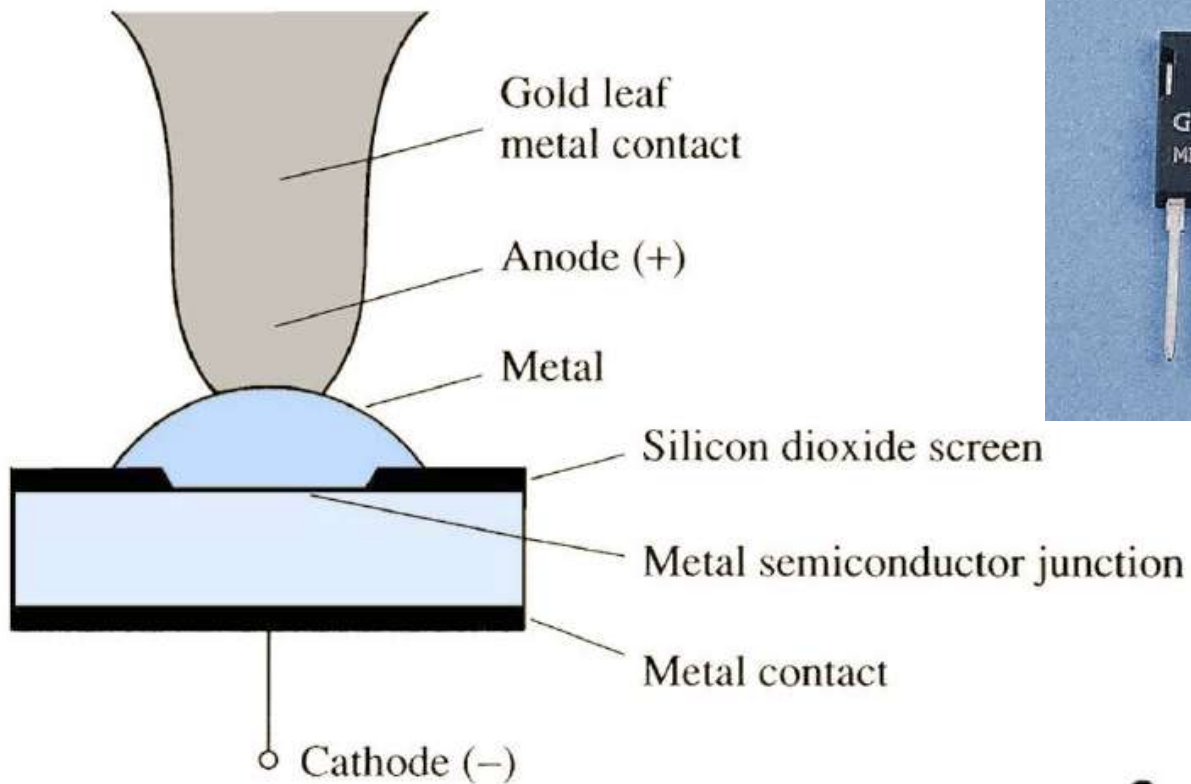

Diodos de barreira Schottky

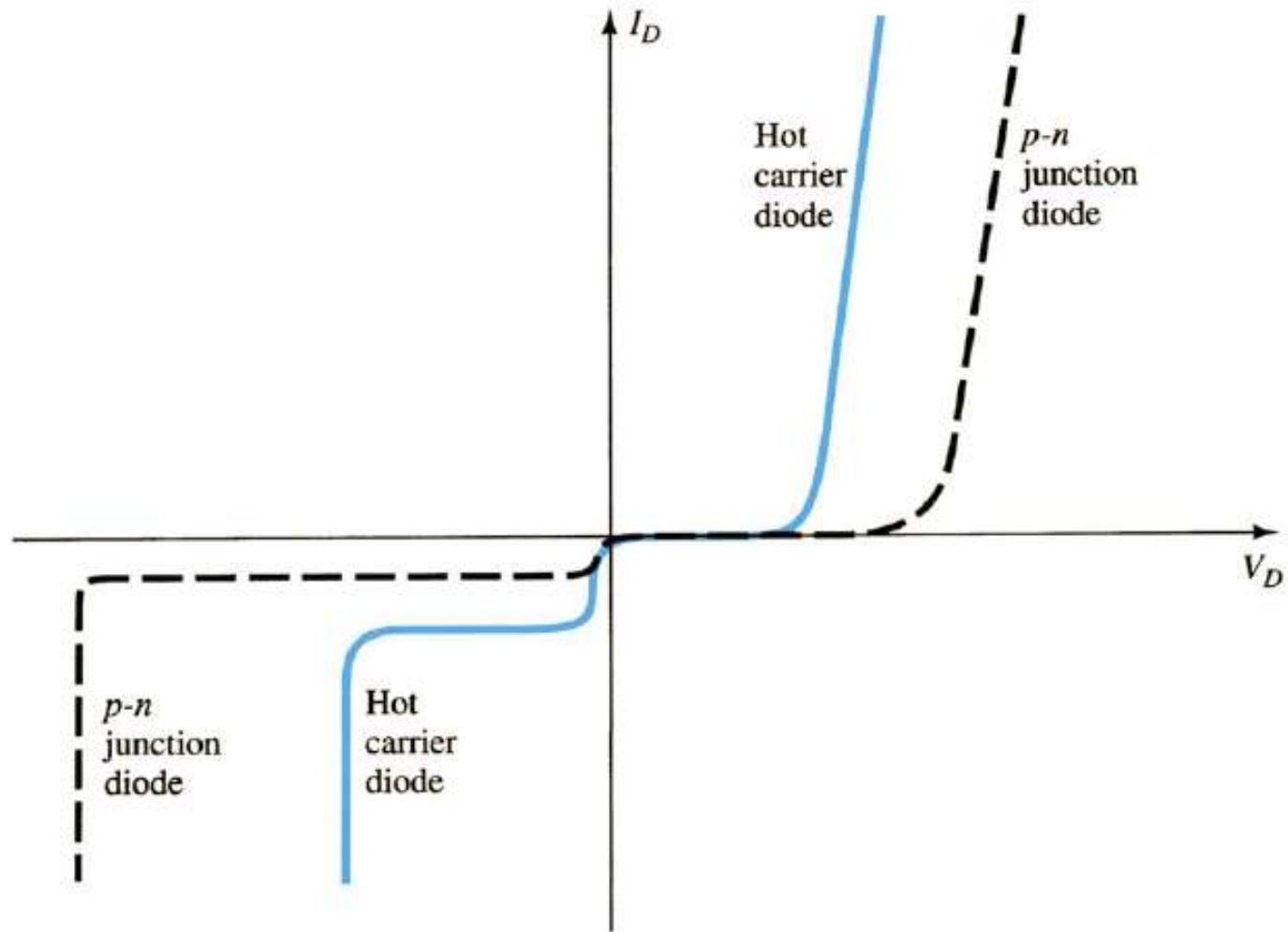

Diodos de barreira Schottky

V_{RRM} (Volts)	Case	0.5 A	1.0 A	
		51-02 (DO-7) Glass	59-04 Plastic	
	Anode:			
	Cathode:			
20		MBR020	IN5817	MBR120P
30		MBR030	IN5818	MBR130P
35				MBR135P
40			IN5819	MBR140P
	I_{FSM} (Amps)	5.0	100	50
	T_C @ Rated I_a (°C)			
	T_J Max	125°C	125°C	125°C
	Max V_F @ $I_{FSM} = I_c$	0.50 V	*0.60 V	0.65 V

Symb.	1N 4001	1N 4002	1N 4003	1N 4004	1N 4005
VRRM	50	100	200	400	600
VRMS	35	70	140	280	420
VDC	50	100	200	400	600
$I_F(AV)$	1.0				
I_{FSM}	30				
$I_R(AV)$	30				
$R_{\theta JA}$ $R_{\theta JL}$	50 25				
T_A	+150				
T_J, T_{STG}	-50 to +175				
V_F	1.1				

Diodo retificador normal

← Diodo Schottky

Diodos varactor (varicap)

Varicap:

- São diodos que variam sua capacitância com a tensão aplicada nos seus terminais.

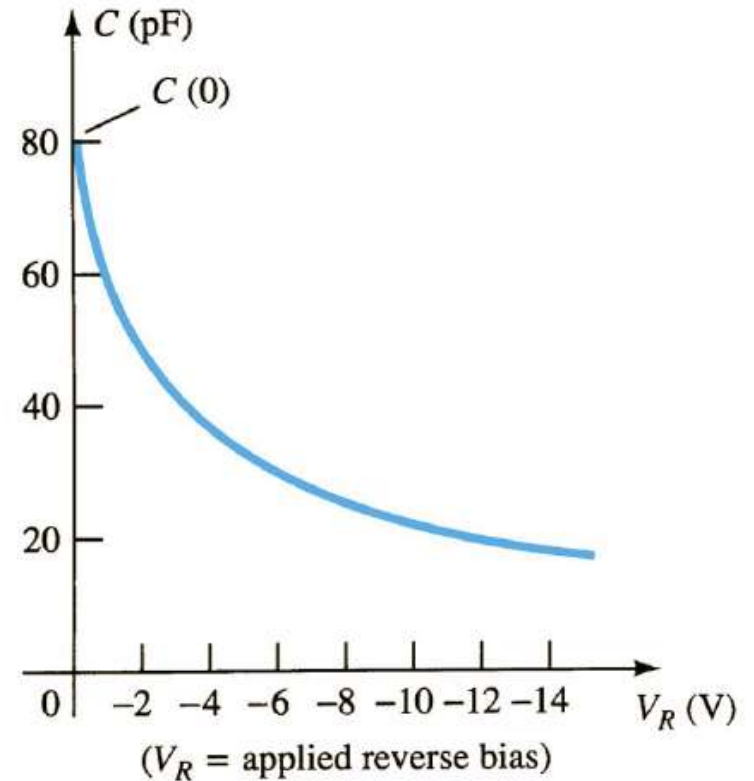
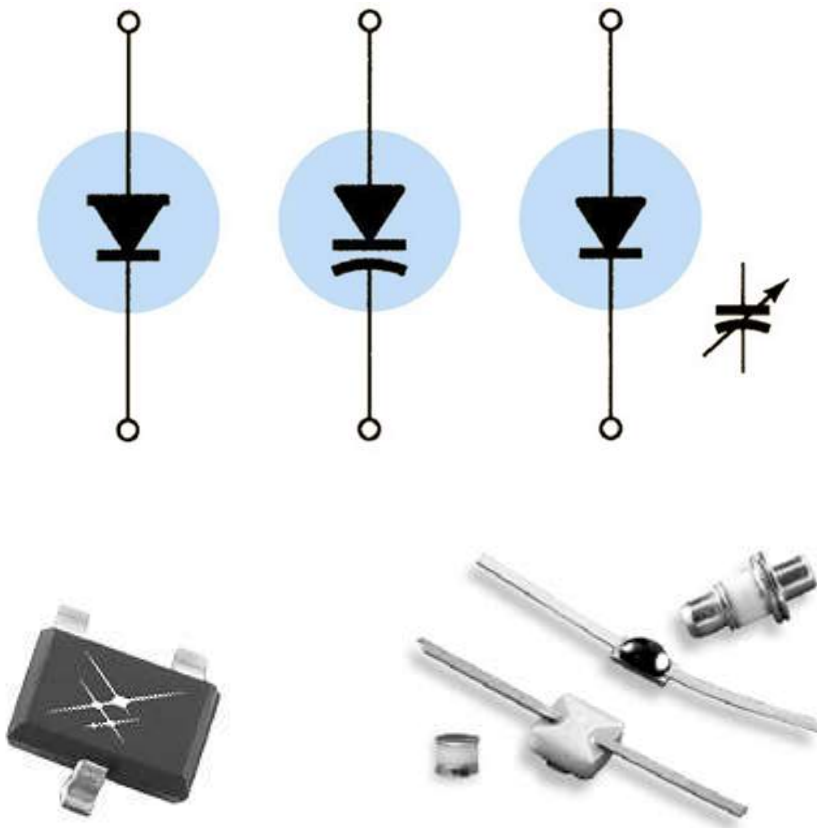

Diodos túnel

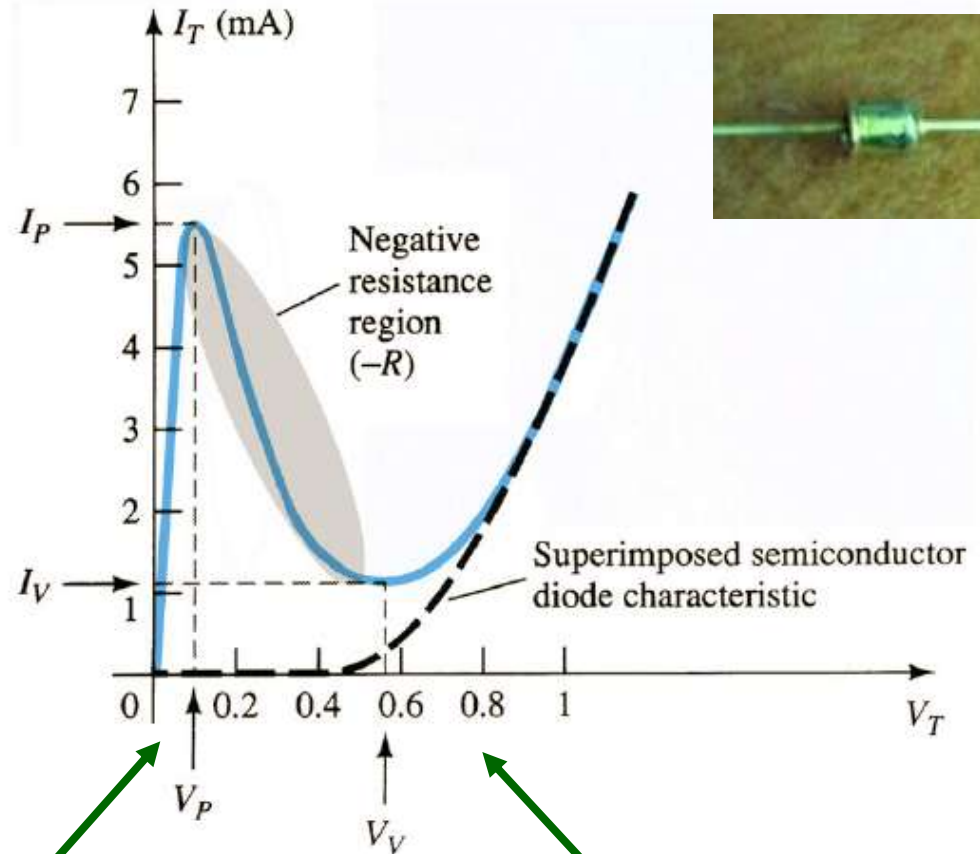
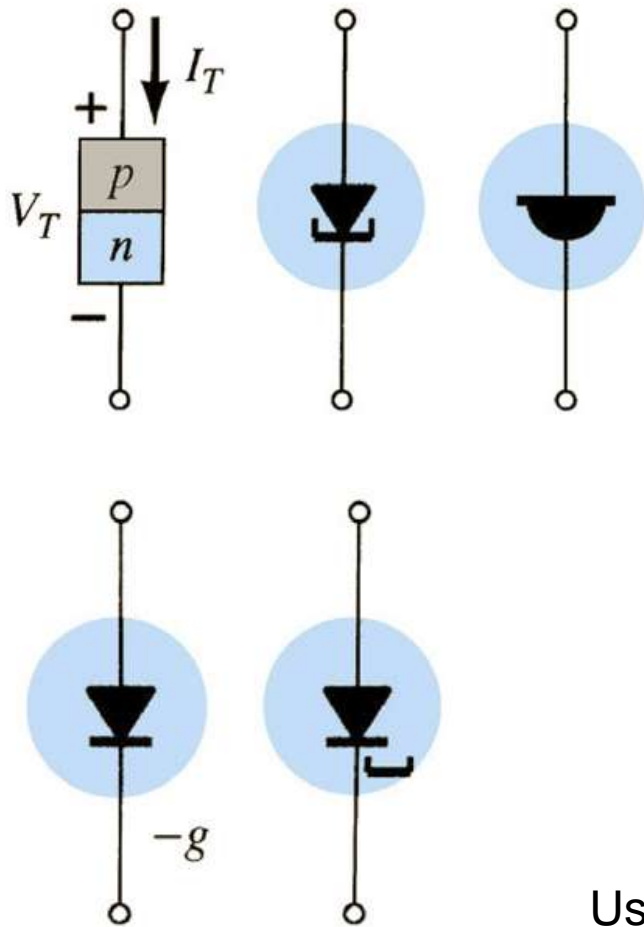

Usado em aplicações que requerem alta velocidade de comutação.

Também usado em circuitos osciladores.

Diodo Shockley

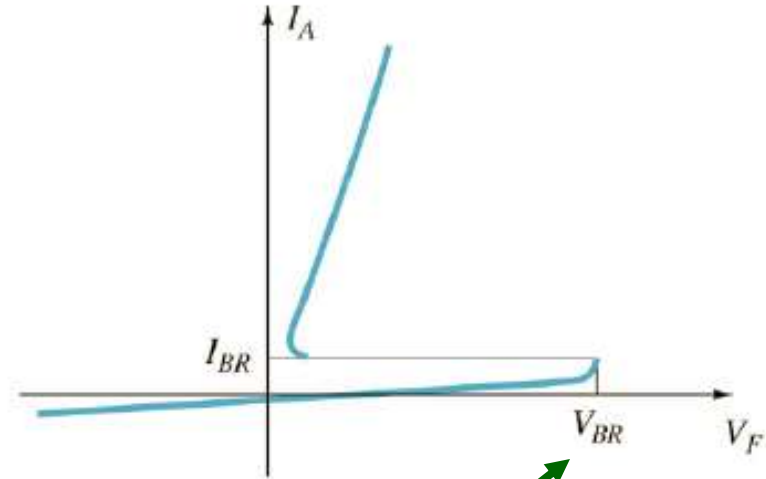
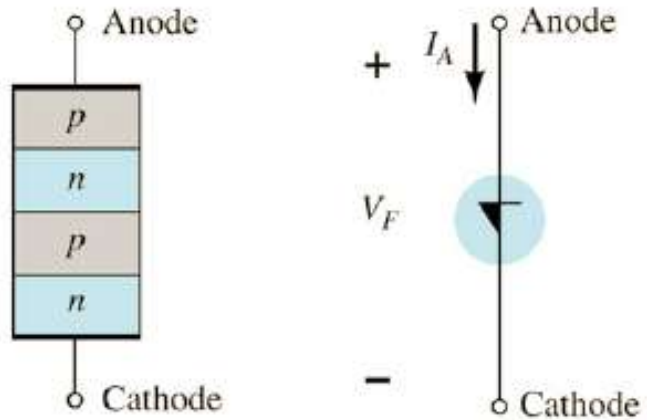

Entra em condução quando é atingida a tensão de ruptura (avalanche).

Diac

Diac – Diode for alternating current
(Diodo para corrente alternada)

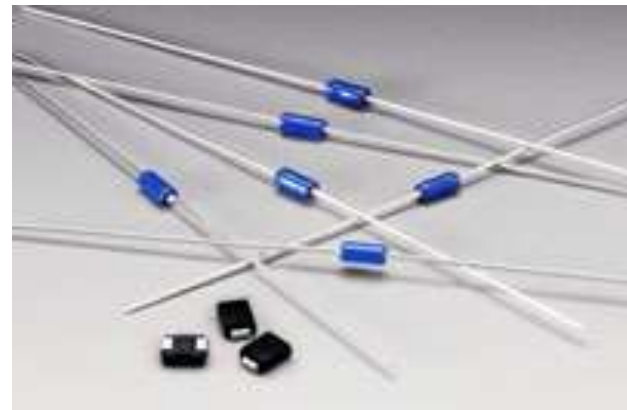
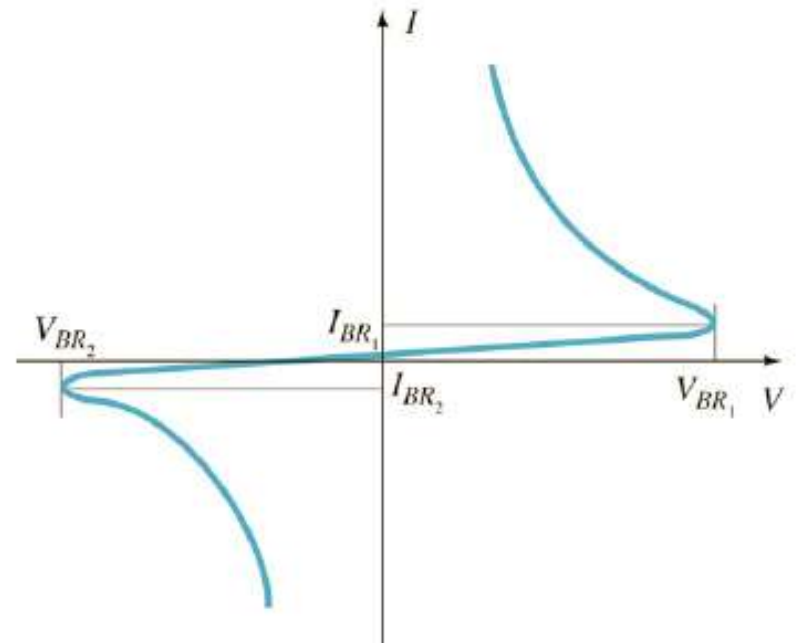
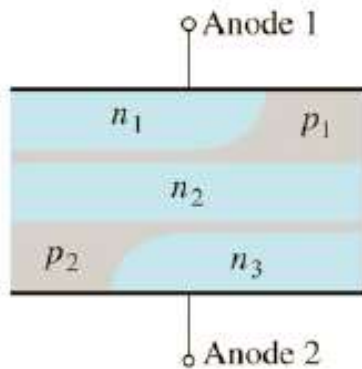
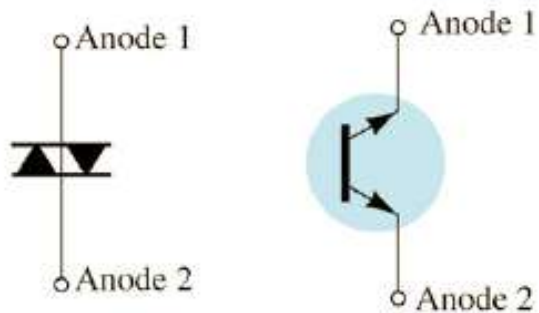

Retificador controlado de silício (SCR)

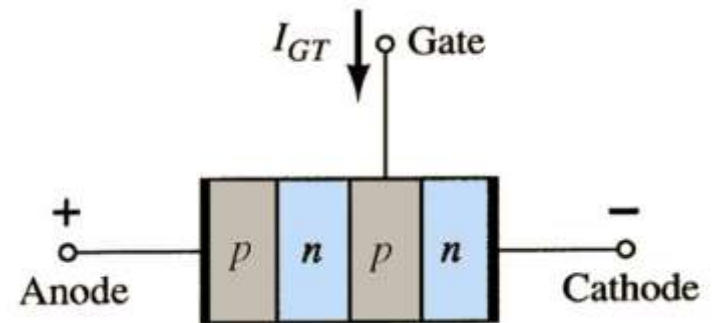
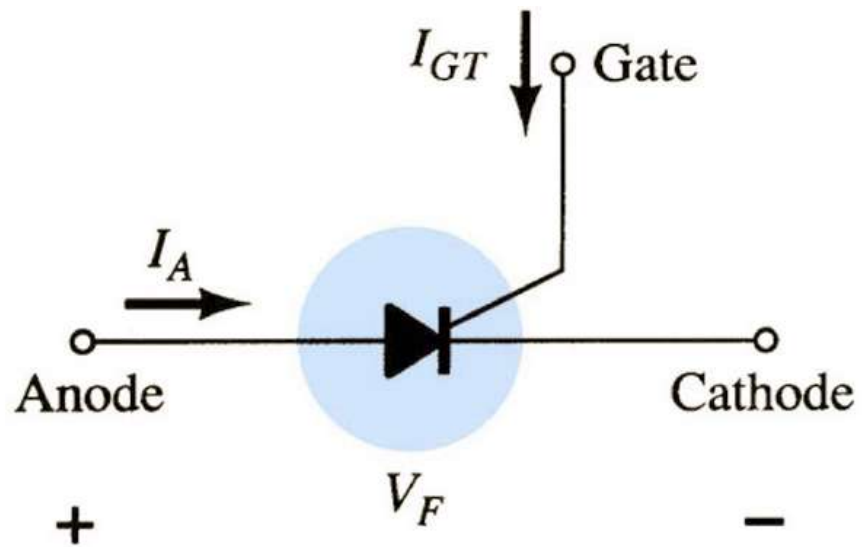

Retificador controlado de silício (SCR)

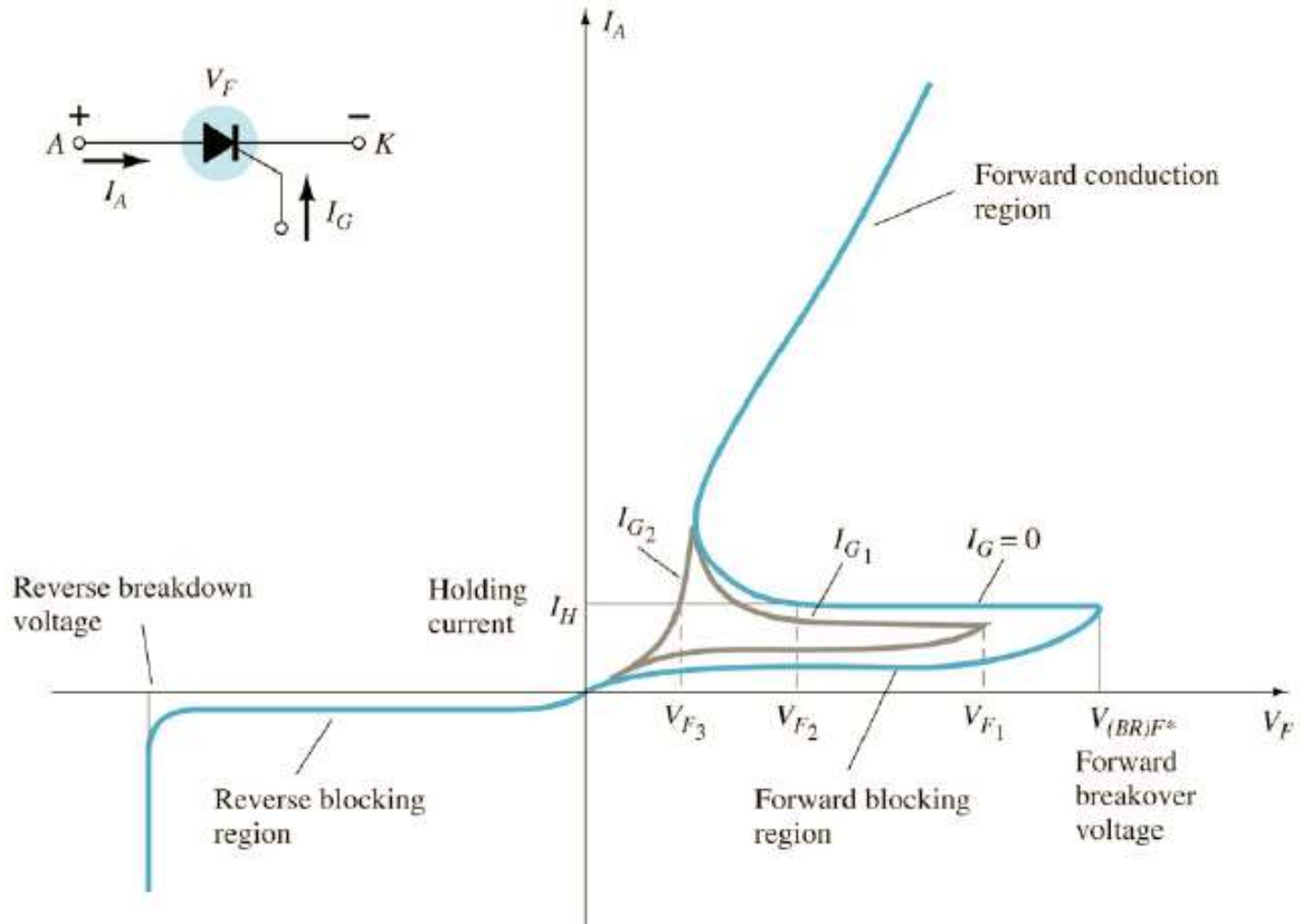

Retificador controlado de silício (SCR)

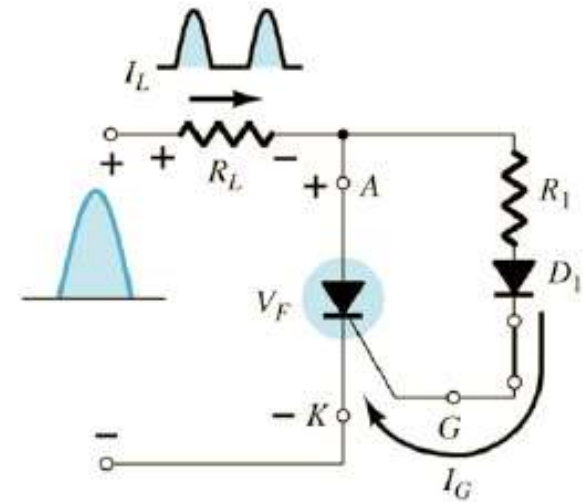
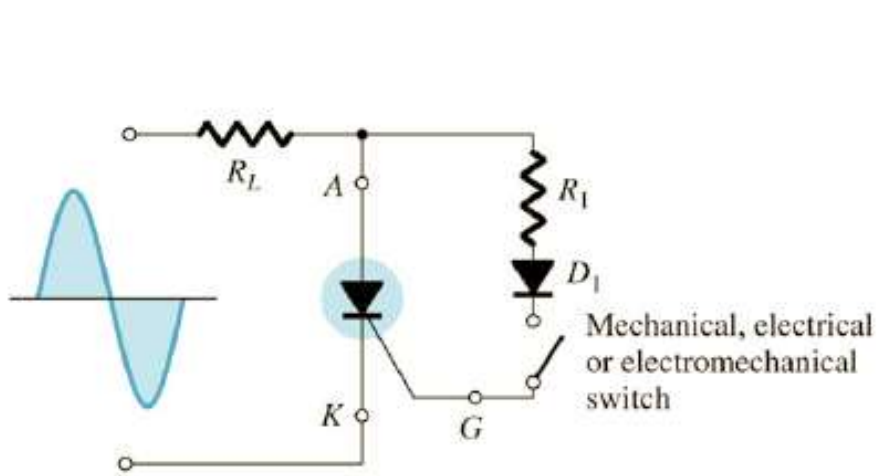

Retificadores de meia onda controlados.

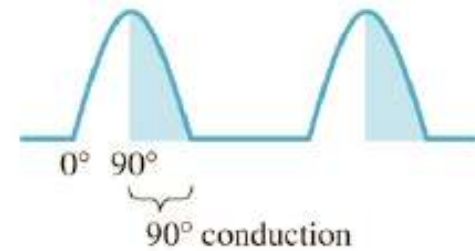
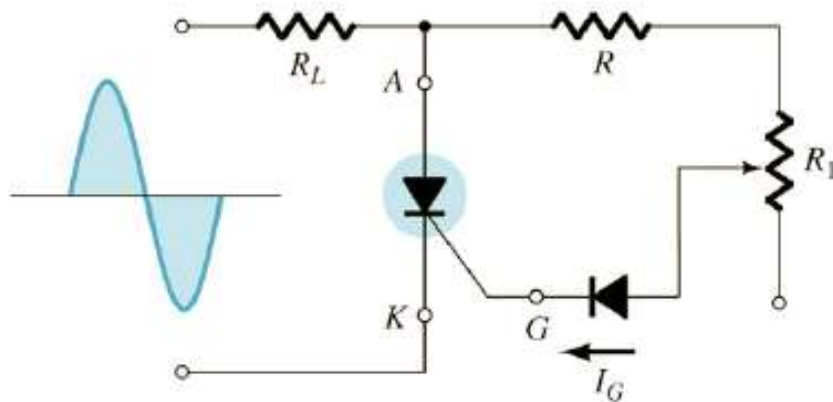

Triac

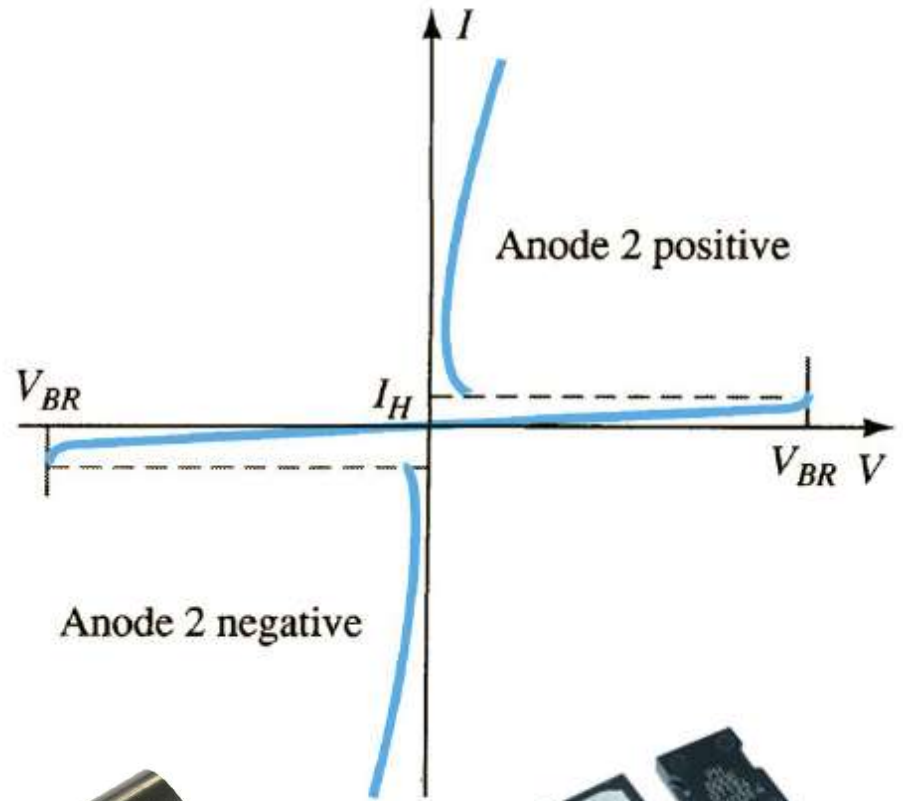
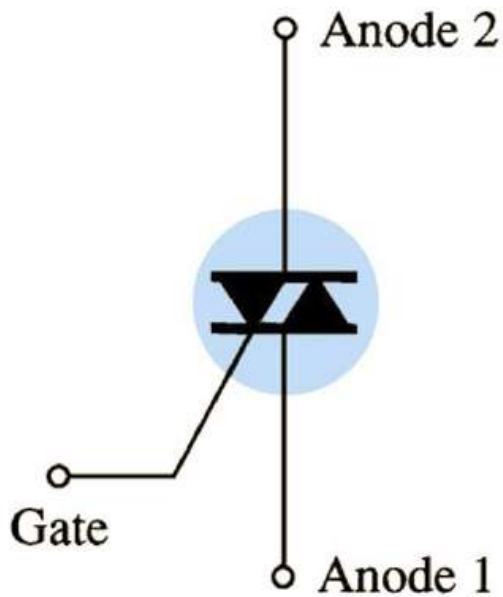

Triac

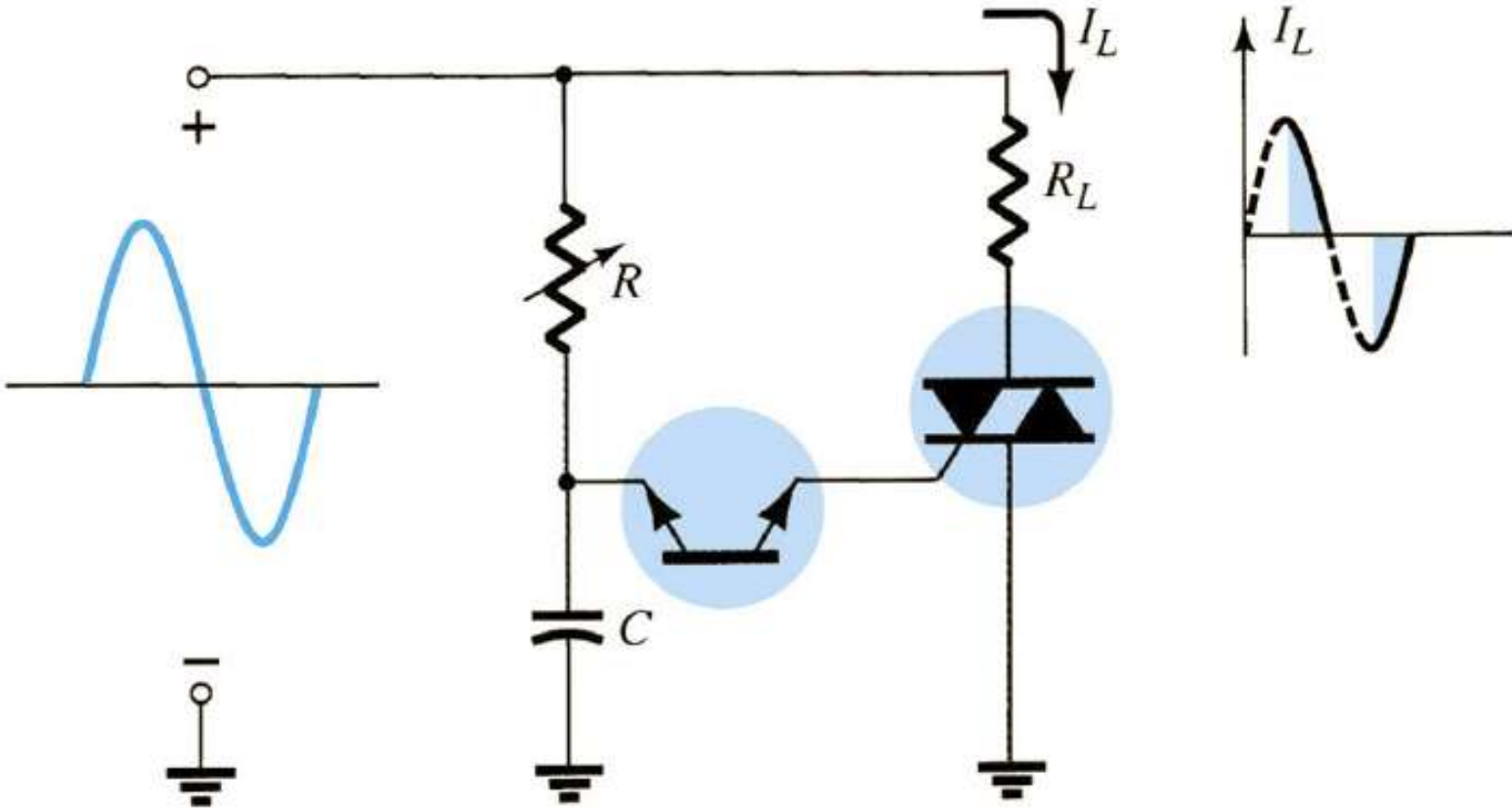

Diodos

LEDs

Diodos emissores de luz (LEDs):

- Eletroluminescência – processo de emissão de luz pela aplicação de uma fonte elétrica de energia.

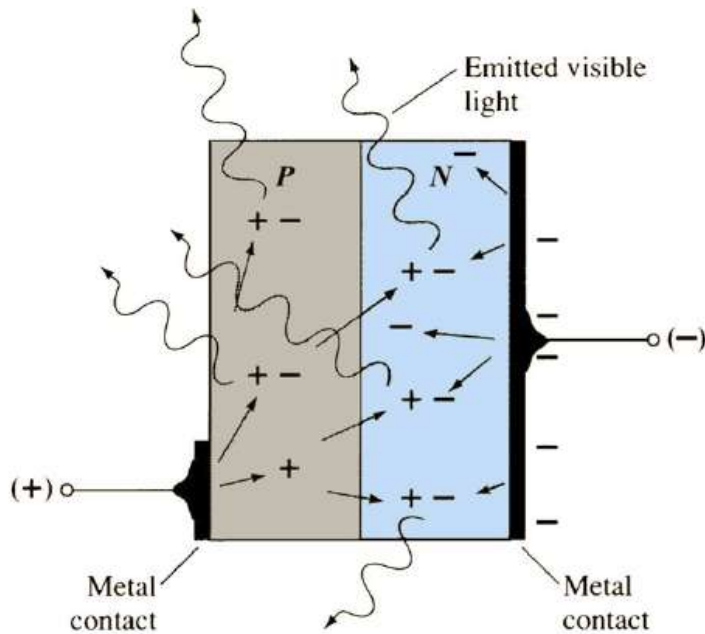

LEDs

Comprimentos de onda dos leds:

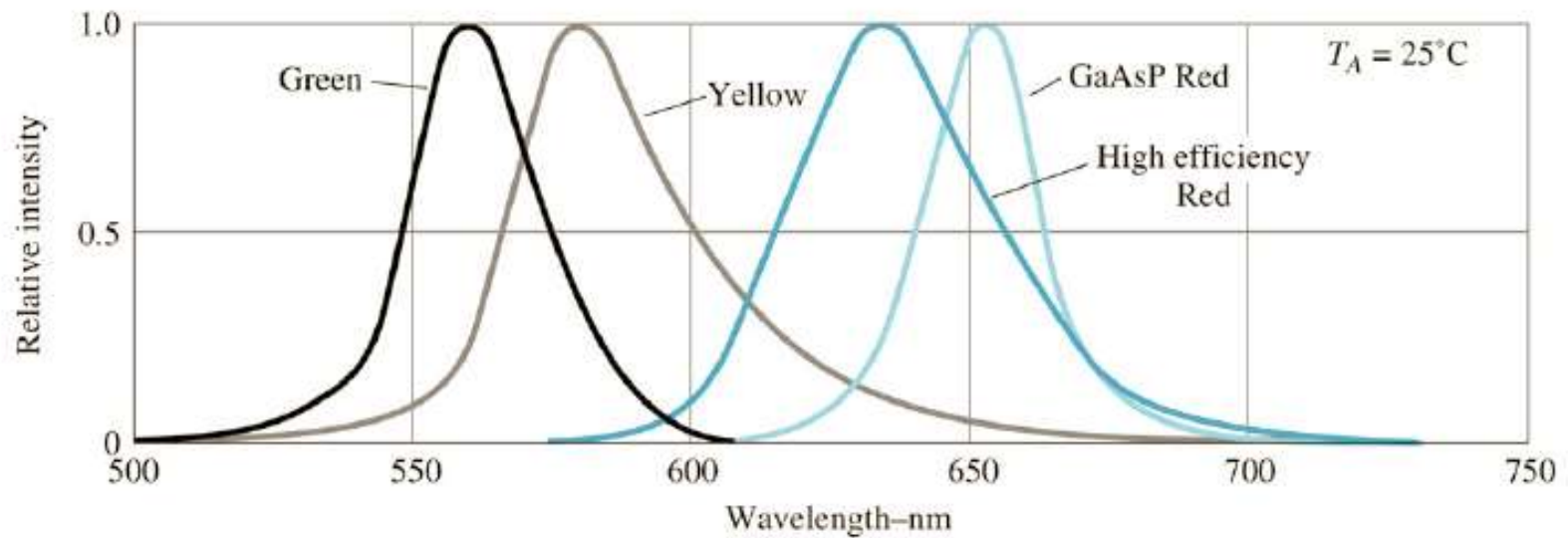

LEDs

Corrente direta versus tensão direta para leds miniatura:

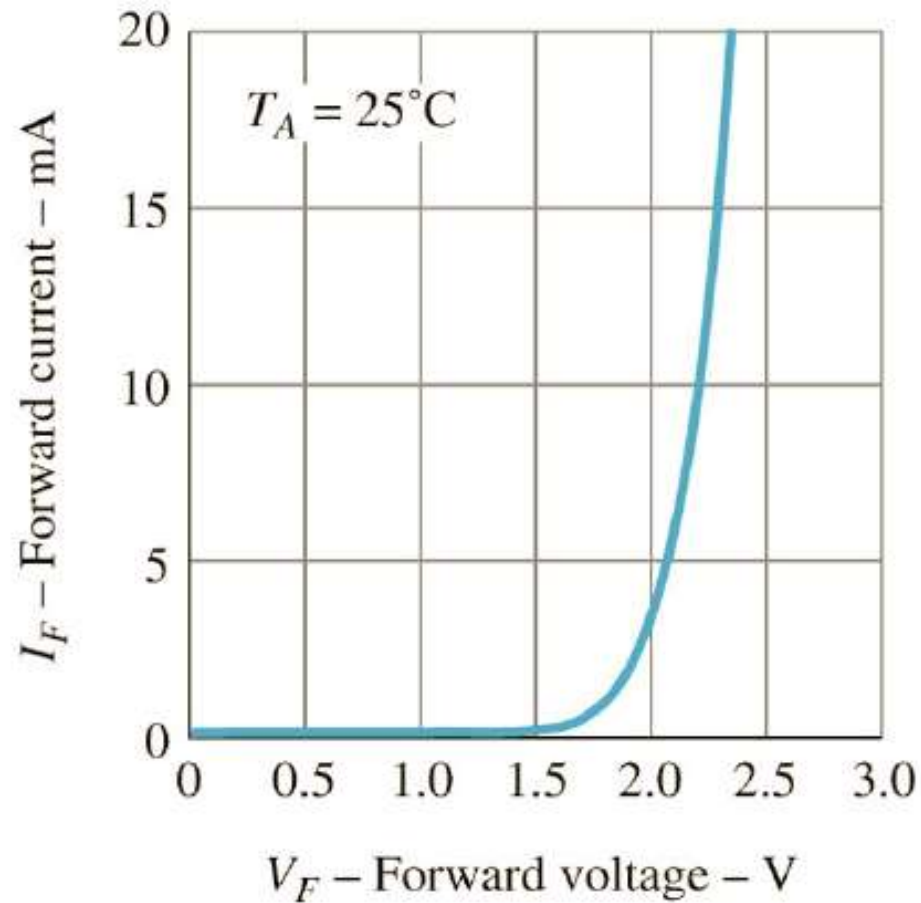

LEDs

Exercícios:

- Dimensionar circuitos com LED conforme especificações de fabricantes.

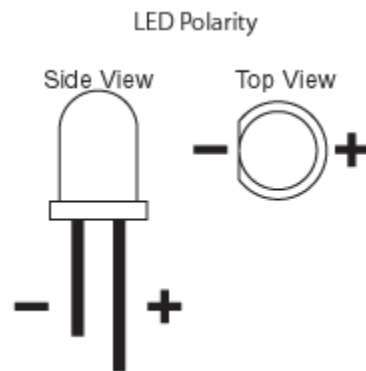

Spec	Value
Product ID	L4-0-Y5TH30-1
Angle	30
Package	5mm
Color	
Peak Wavelength in nm	590
Luminous Intensity	5000mcd typ. @ 20mA
Max Forward Current	30mA
Max Forward Current Pulse	100mA for $\leq 10\text{ms}$, duty $\leq 1/10$
Forward Voltage	2.25V typ. 2.6V max @ 20mA
Max Reverse Voltage	5V
Power Dissipation	
Operating Temp	-30 to +85 C
Soldering Temp	260 C for 5 Sec.
Max Reverse Current	10uA @ 5V

LEDs

SPECIFICATIONS FOR UPEC POWER LIGHT SOURCE TYPE LED

Absolute Maximum Ratings at Ta=25°C

Parameter	Symbol	Max	Unit
Power Dissipation	PD	3	W
Pulse Forward Current	IPF	1000	mA
Forward Current	IF	700	mA
Reverse Voltage	VR	5	V
Operating Temperature Range	Topr	- 40 to +85	°C
Storage Temperature Range	Tstg	- 40 to + 85	°C

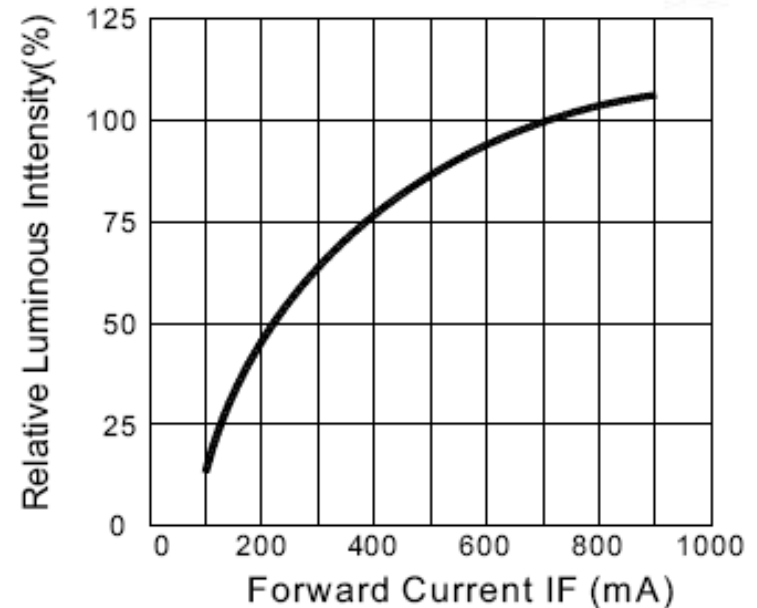
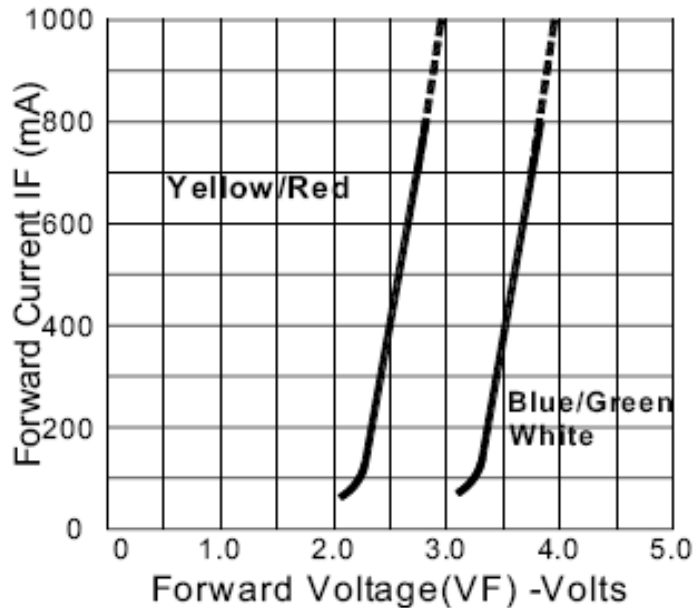
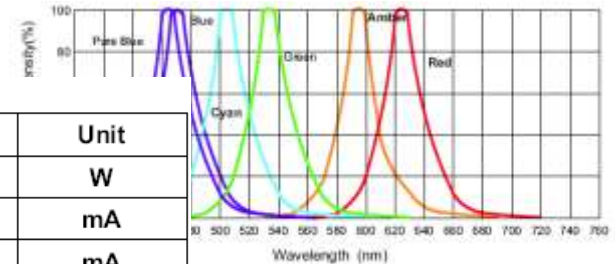

LEDs

SPECIFICATIONS FOR UPEC LTCC LIGHT SOURCE LED

MAXIMUM RATINGS

Parameter	Symbol	Values			Unit
		Red	Pure Green	Blue	
Operating temperature range	T_{op}	-40 ... + 85			°C
Storage temperature range	T_{stg}	-40 ... +100			°C
Power dissipation (Max)	P_d	2			W
Pulse forward current per chip	I_{pf}	250	300	250	mA
Forward current (R,G,B)	I_f	150	200	150	mA
Test current (White mixed)	I_f	100	200	50	mA
Reverse voltage	V_r	5			V



CHARACTERISTICS ($T_J = 25\text{ }^{\circ}\text{C}$)

Parameter	Symbol	Values			Unit
		Red	Pure Green	Blue	
Dominant wavelength	λ_{dom}	620~630	520~530	455~465	nm
Spectral bandwidth at 50 % (Typ)	$\Delta\lambda$	20	30	20	nm
Viewing angle at 50% I_v	$2\theta_{1/2}$	120	120	120	deg.
Forward voltage	V_f	2.0 3.0	2.8 3.6	2.8 3.6	V
Reverse current	I_r	100			μA

LEDs

SPECIFICATIONS FOR UPEC LED LIGHT SOURCE TYPE SYSTEM

Absolute Maximum Ratings at $T_a=25^{\circ}\text{C}$

Parameter	Symbol	Max	Unit
Power Dissipation	PD	6	W
Pulse Forward Current	IPF	500	mA
Forward Current	IF	350	mA
Operating Temperature Range	Topr	- 40 to + 120	$^{\circ}\text{C}$
Storage Temperature Range	Tstg	- 40 to + 120	$^{\circ}\text{C}$

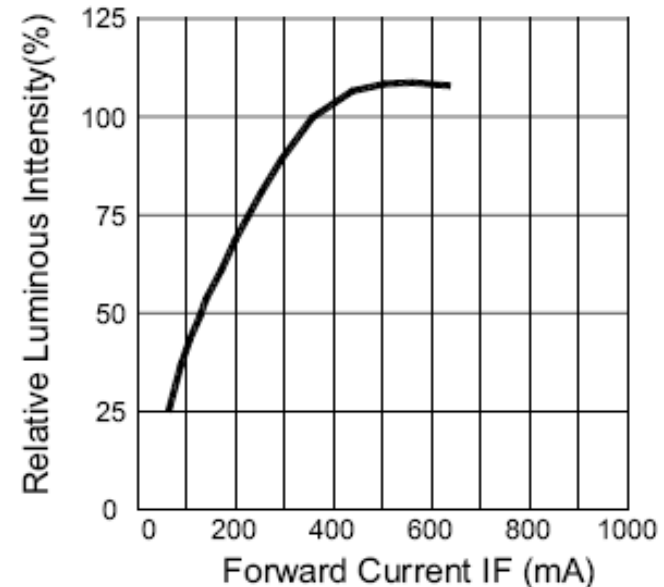
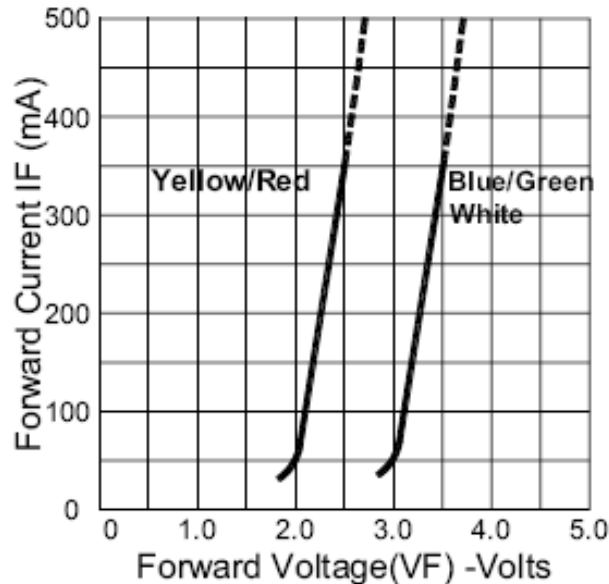

Fotodiodos

Fotodiodos:

- São diodos que operam na região reversa e são sensíveis à luz.
- Optoeletrônica – campo de estudo dos dispositivos sensíveis à luz.

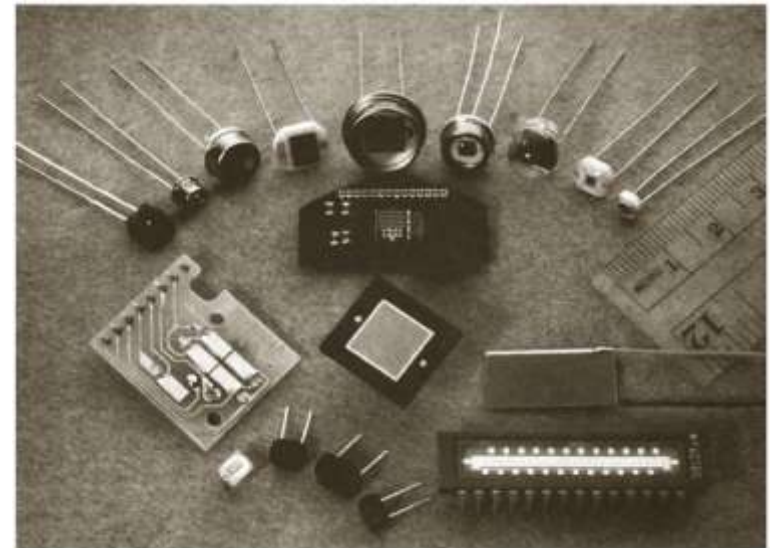
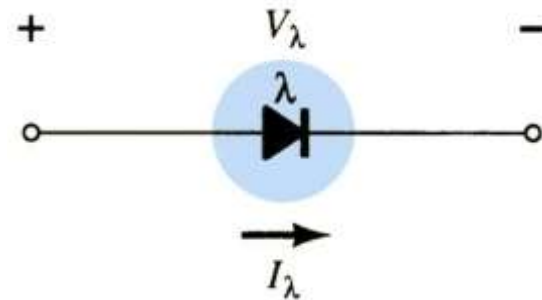
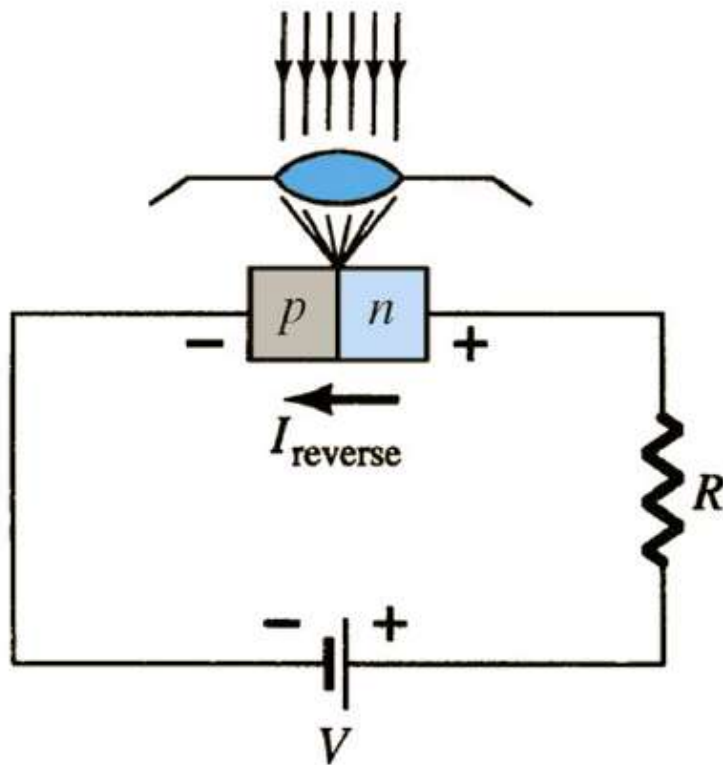

Fotodiodos

Curvas características dos fotodiodos:

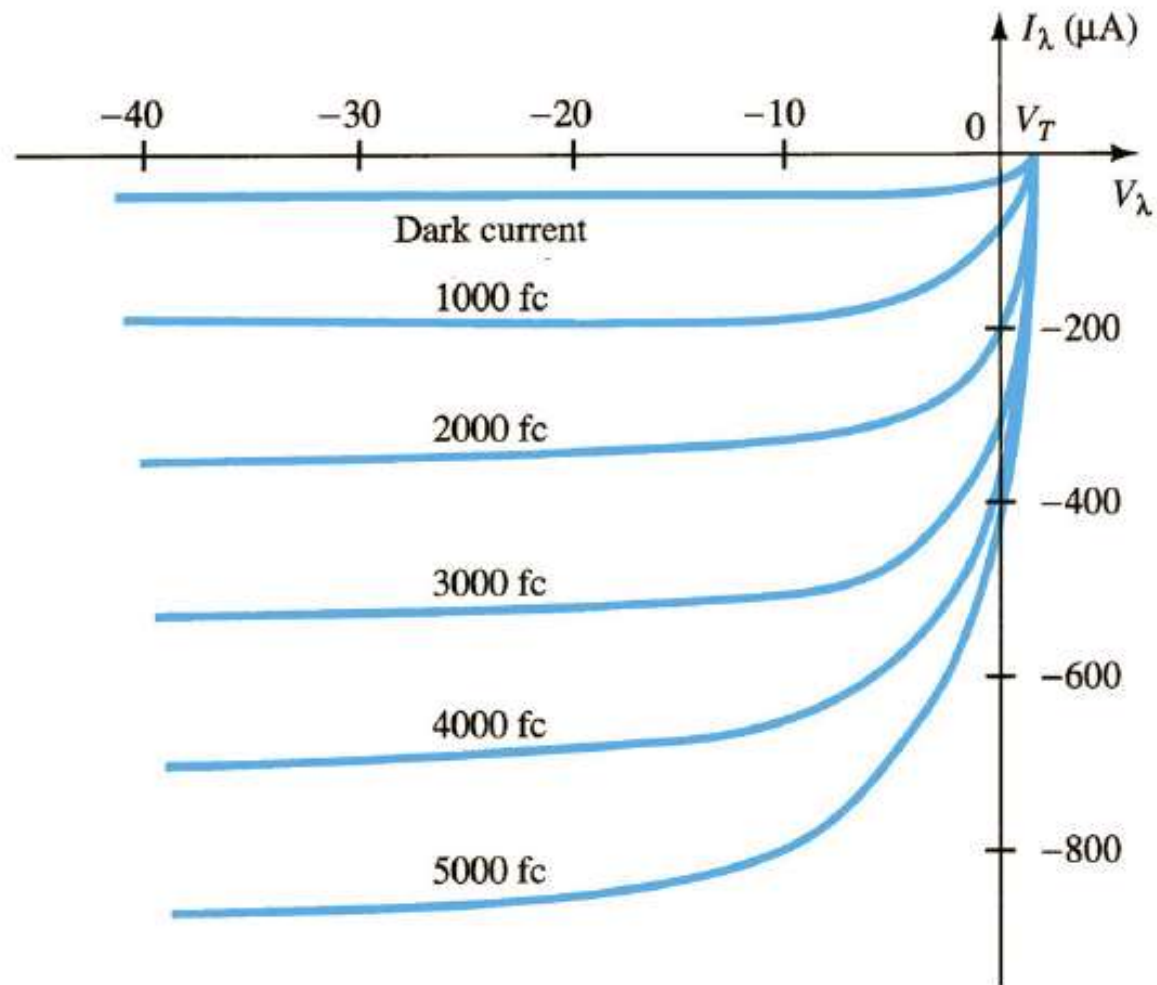

Fotodiodos

Resposta espectral de fotodiodos:

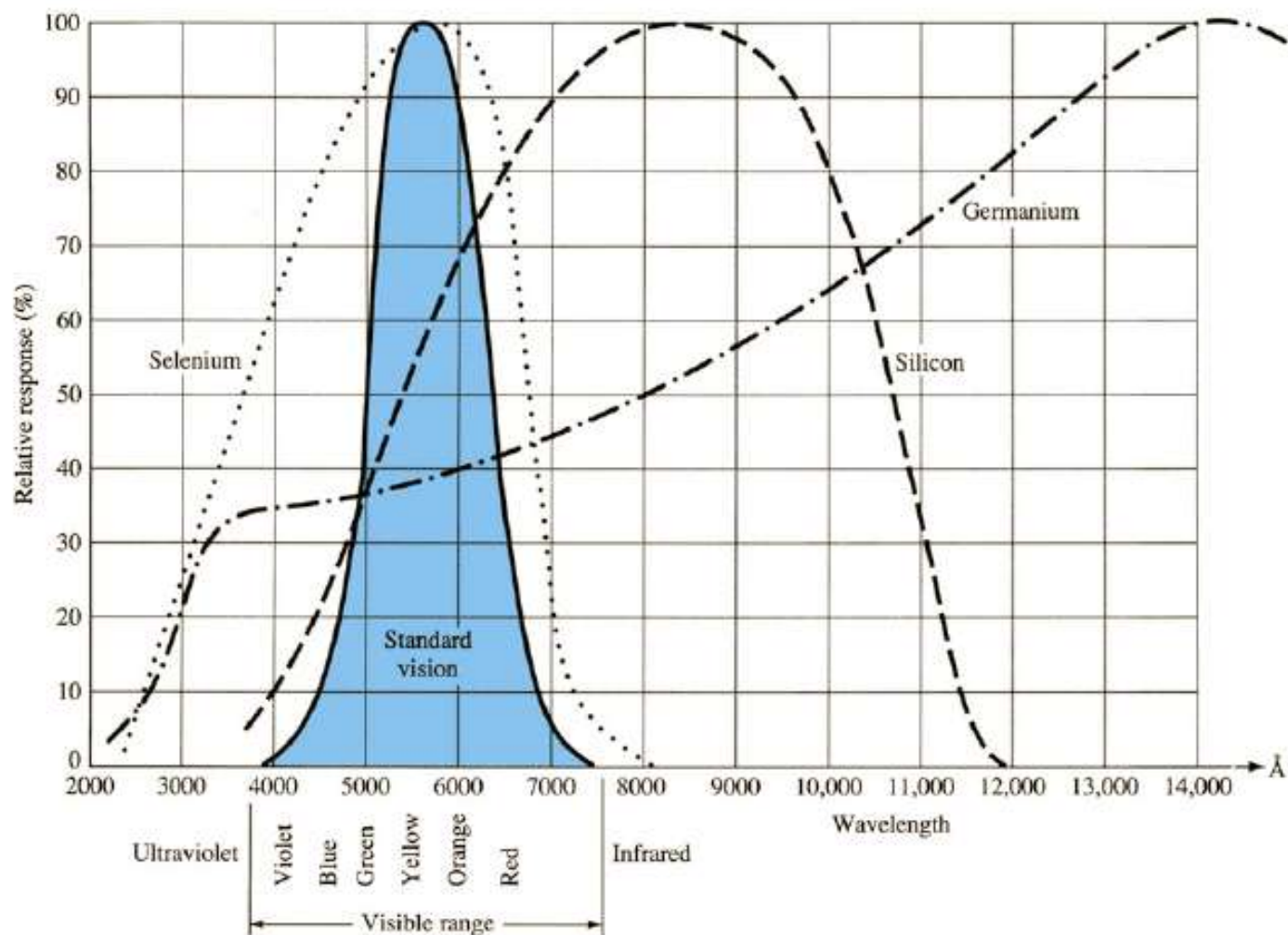

Fotodiodos

Exemplo de aplicação:

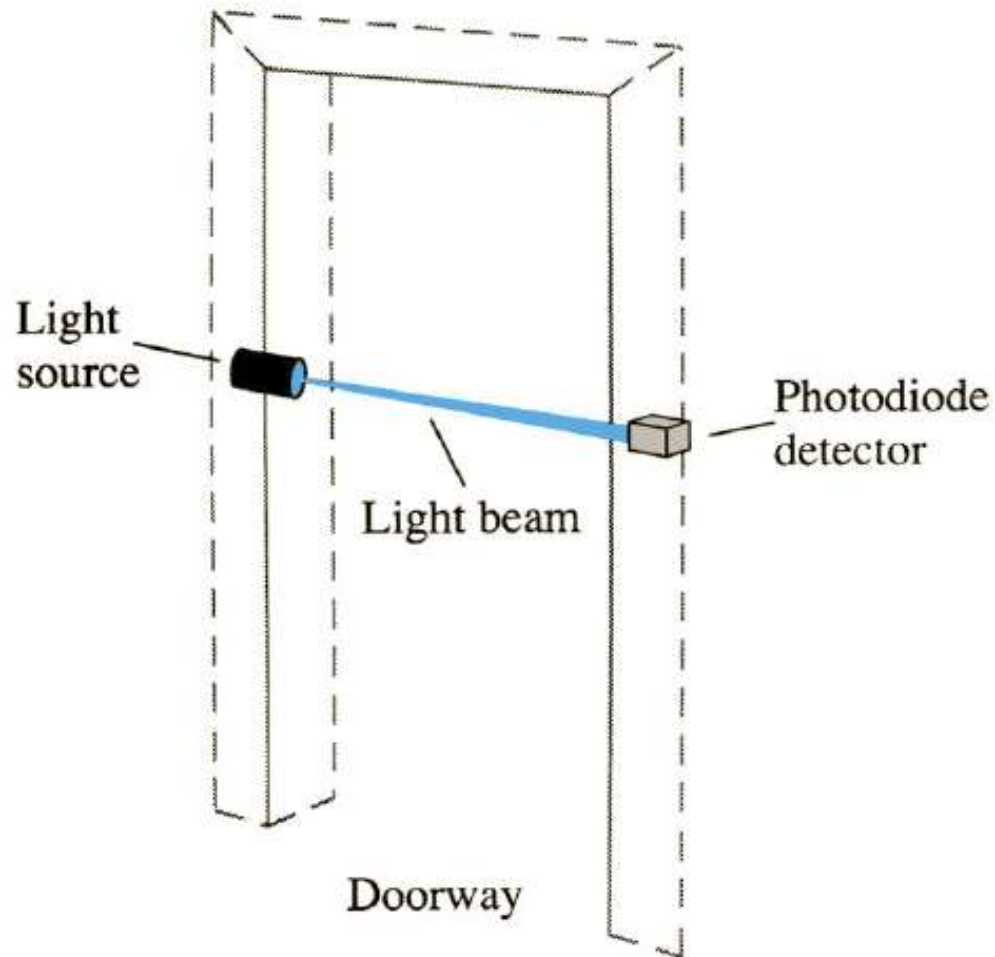

Transistores

Fototransistor

Fototransistor:

- São transistores sensíveis à luz.



Optoacopladores

Optoacoplador:

- São dispositivos que possuem no mesmo encapsulamento um fotodiodo e um fototransistor (ou tiristor), montados de maneira a permitirem o acoplamento óptico entre os dois.
- Usados para isolação entre circuitos, pois não ocorre ligação elétrica entre os circuitos, por exemplo para transmissão de dados.

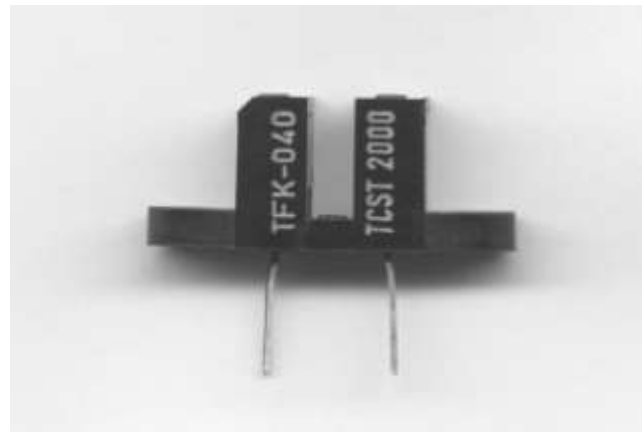

Optoacopladores



March 2007

4N25M, 4N26M, 4N27M, 4N28M, 4N35M, 4N36M, 4N37M,
H11A1M, H11A2M, H11A3M, H11A4M, H11A5M
General Purpose 6-Pin Phototransistor Optocouplers

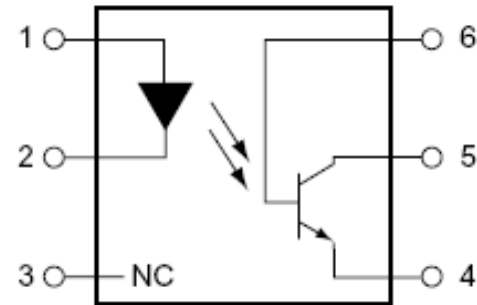
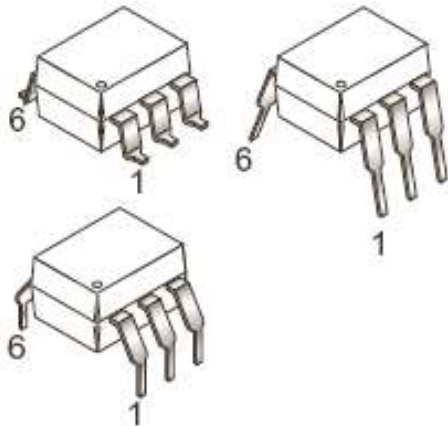

- PIN 1. ANODE
- 2. CATHODE
- 3. NO CONNECTION
- 4. EMITTER
- 5. COLLECTOR
- 6. BASE

TEST CIRCUIT

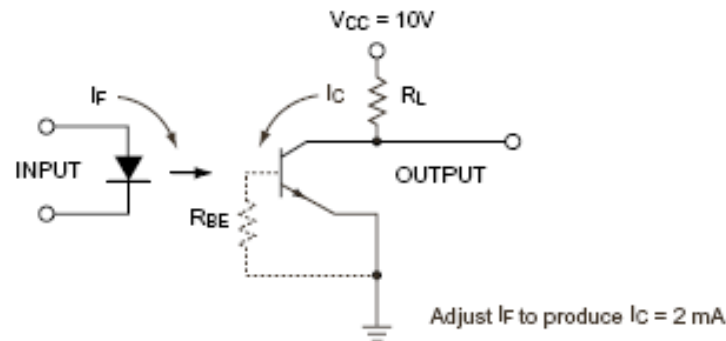

WAVE FORMS

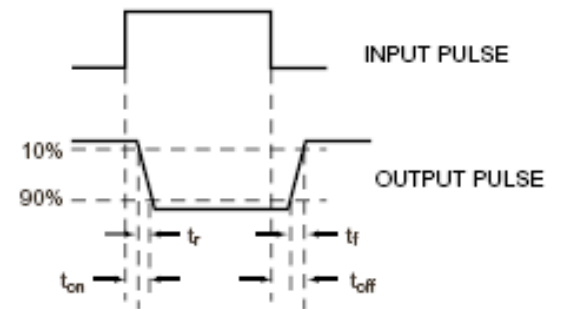

Optoacopladores

Optoacoplador com saída tiristorizada:

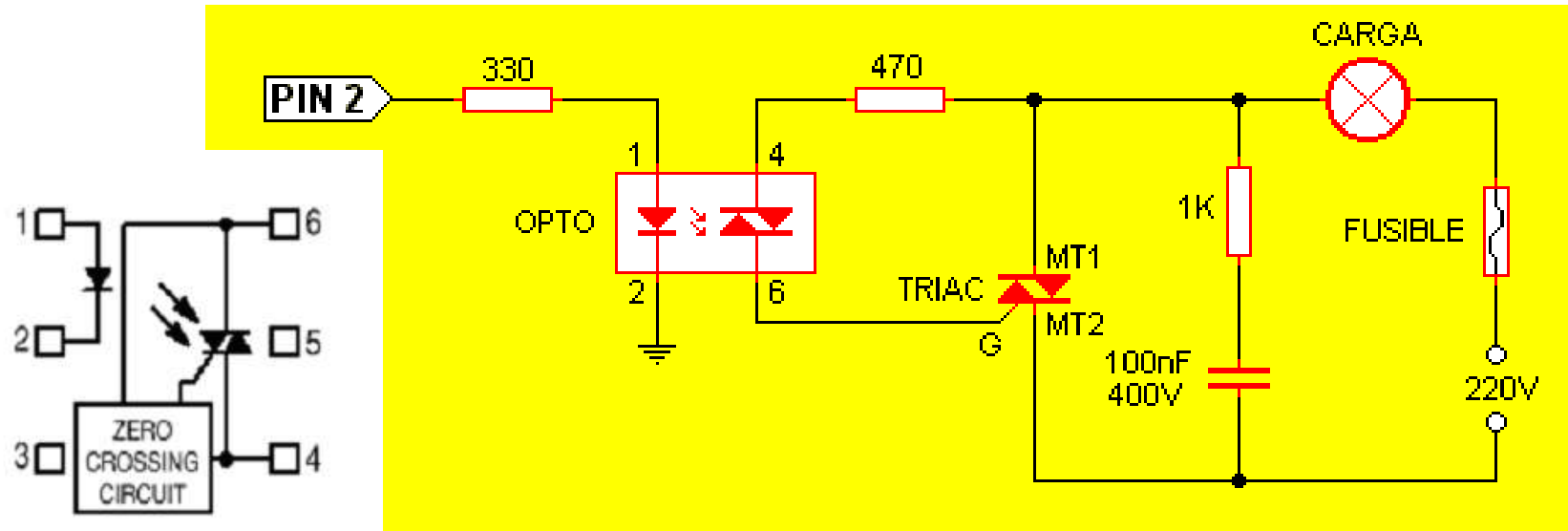

1. ANODE
2. CATHODE
3. NC
4. MAIN TERMINAL
5. SUBSTRATE
DO NOT CONNECT
6. MAIN TERMINAL

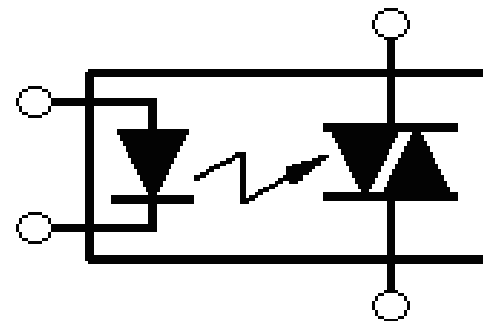

Outros Dispositivos

Células solares

Células solares:

- São dispositivos construídos a partir de materiais semicondutores e que são sensíveis à luz.
- Geram potências da ordem de mW quando iluminados.

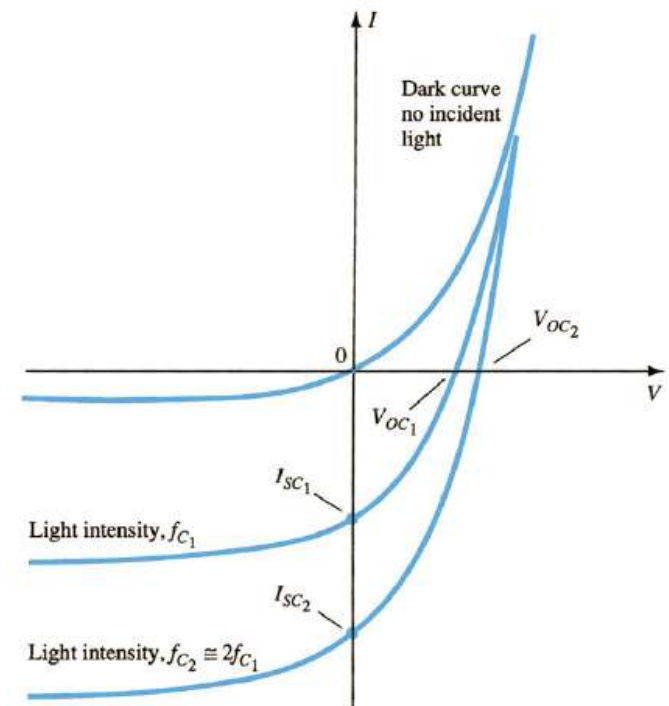
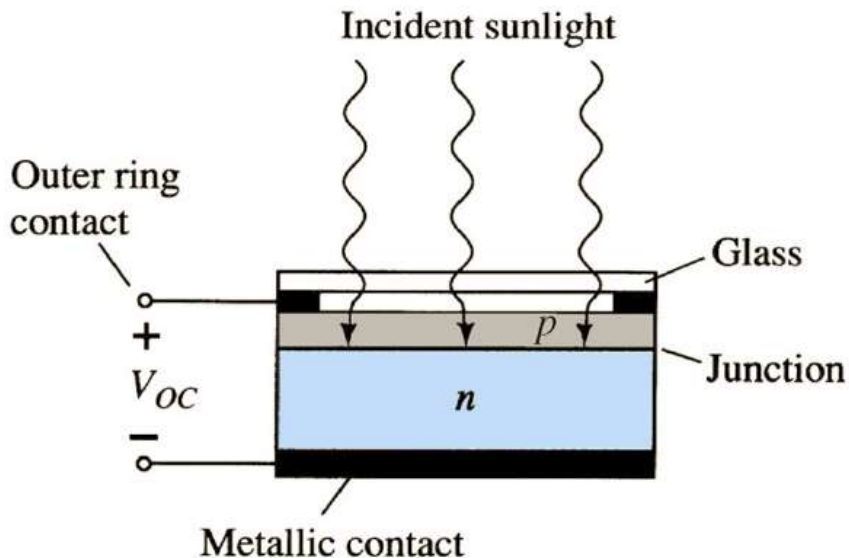

Células solares

Células solares:

- São dispositivos construídos a partir de materiais semicondutores e que são sensíveis à luz.
- Geram potências da ordem de mW quando iluminados.

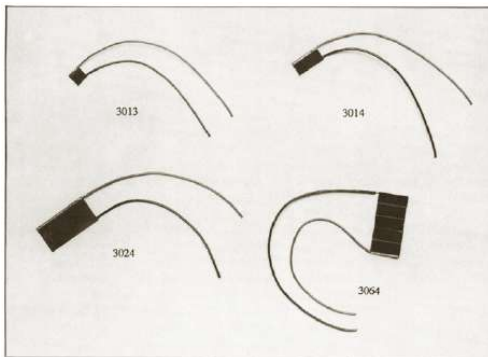

Semicondutores de Carbeto de Silício

Diodos de silicón carbide

Principal característica:

- Diminuem acentuadamente o fenômeno da recuperação reversa.

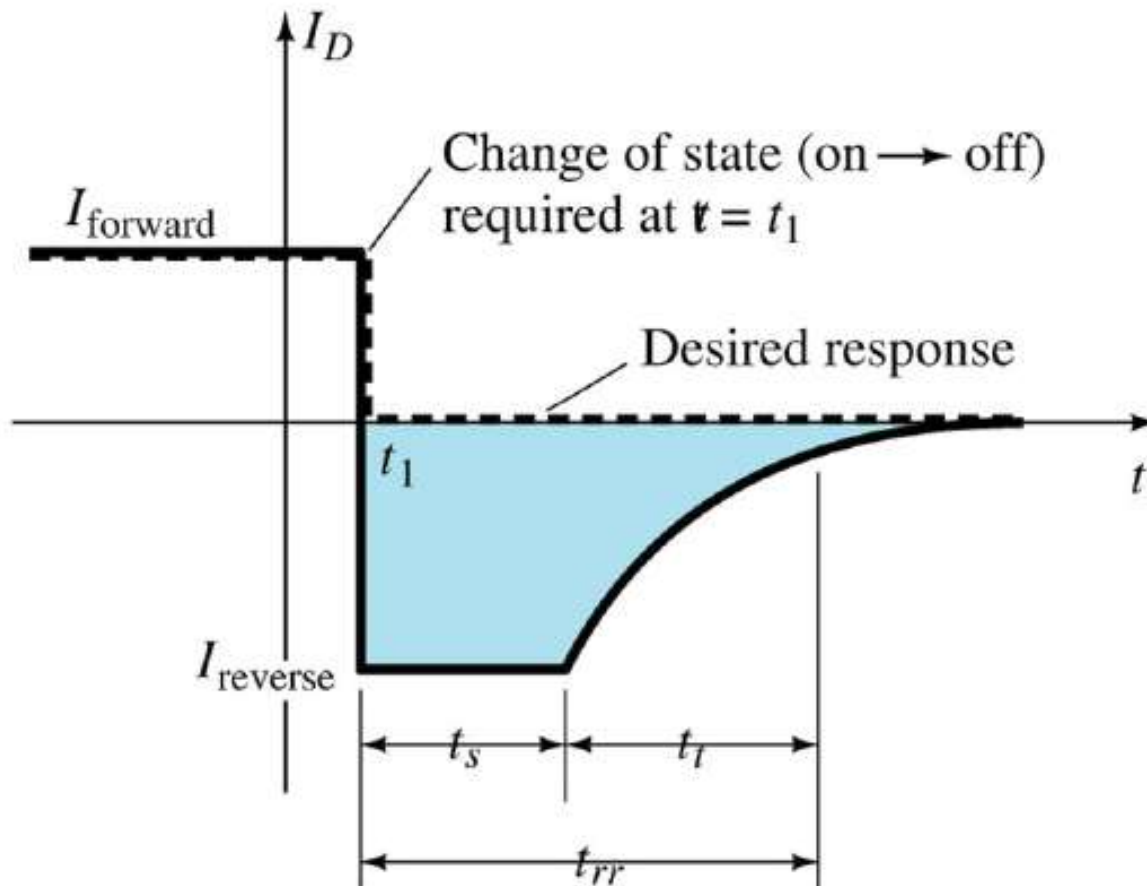

<http://www.infineon.com>

<http://www.cree.com>

Diodos de silicon carbide x silício (SiC x Si)

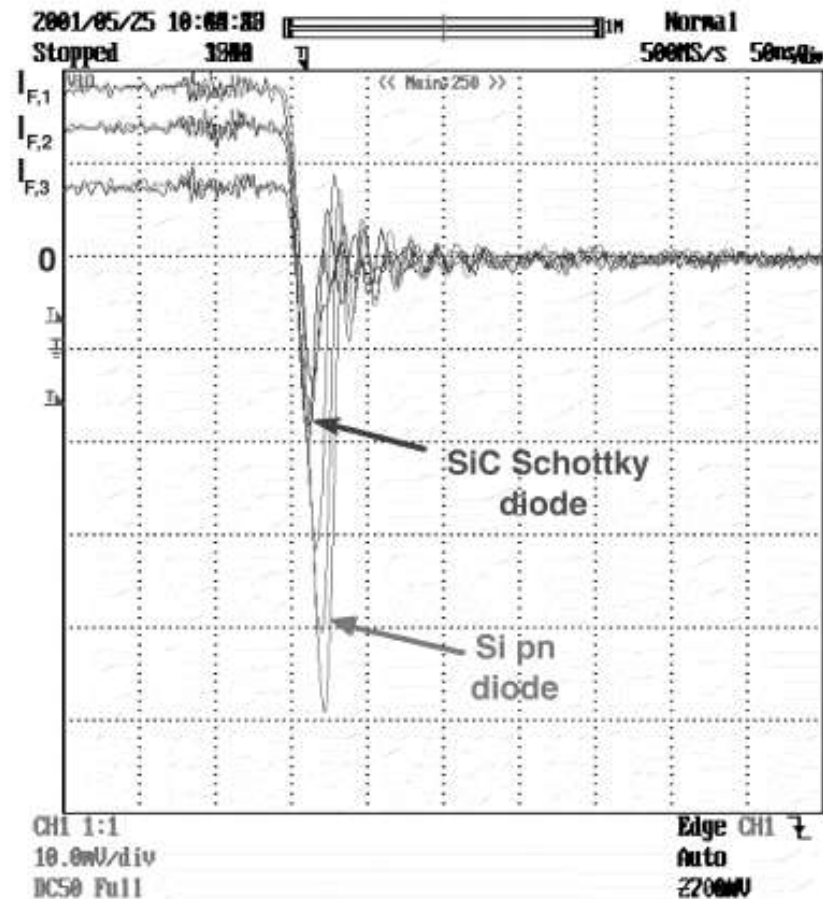

Fig. 5. Typical reverse recovery waveforms of the Si pn and SiC Schottky diode for three different forward currents (2 A/div.).

Diodos de silicon carbide x silício (SiC x Si)

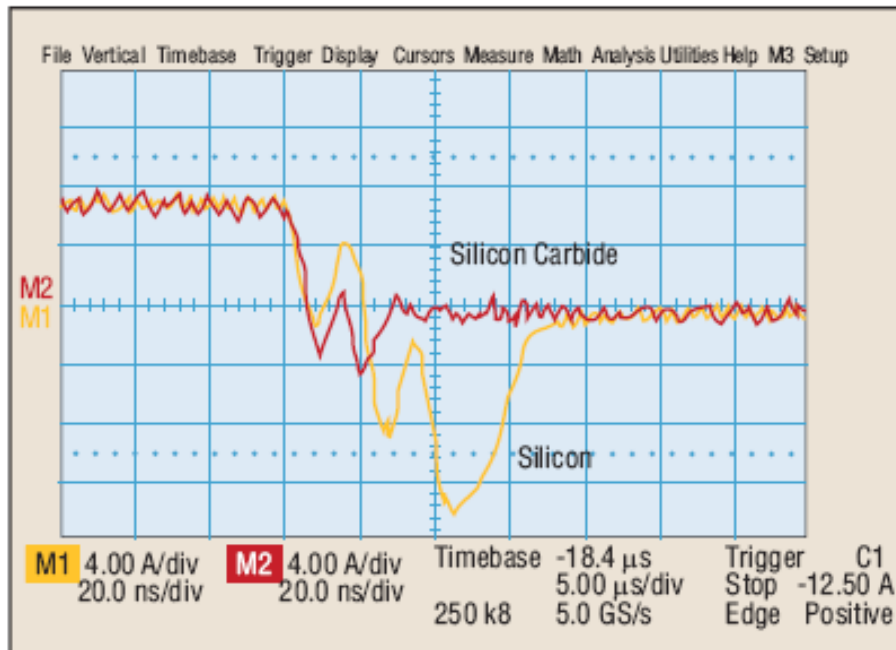

Fig. 4. Low-line diode recovery currents in PFC front-end converter.

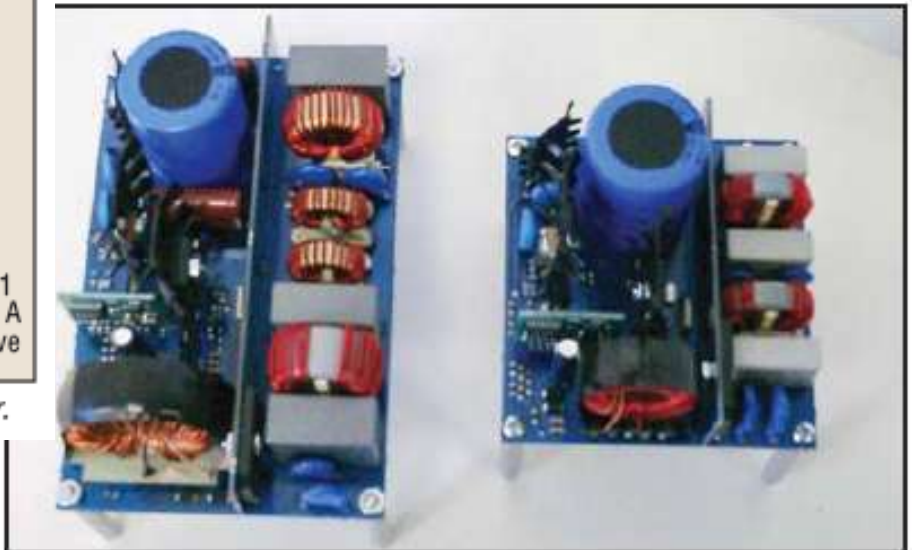

Fig. 8. A size comparison of an 80-kHz PFC front-end built with Si rectifiers (left) and a 200-kHz PFC front-end with SiC rectifiers.

Diodos de silicón carbide



C2D20120D—Silicon Carbide Schottky Diode *ZERO RECOVERY*[®] RECTIFIER

$$V_{RRM} = 1200 \text{ V}$$

$$I_F = 20 \text{ A}$$

$$Q_c = 122 \text{ nC}$$

Features

- 1200-Volt Schottky Rectifier
- Zero Reverse Recovery
- Zero Forward Recovery
- High-Frequency Operation
- Temperature-Independent Switching Behavior
- Extremely Fast Switching
- Positive Temperature Coefficient on V_f

Benefits

- Replace Bipolar with Unipolar Rectifiers
- Essentially No Switching Losses
- Higher Efficiency
- Reduction of Heat Sink Requirements
- Parallel Devices Without Thermal Runaway

Package



TO-247-3

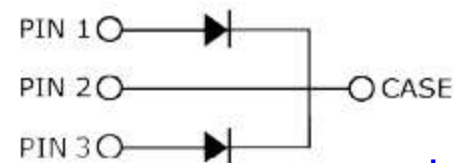

LEDs de silicon carbide

The Real Color DisplayT, a moving sign which is capable of displaying the full range of colors, made possible by the use of blue LEDs.

New Products: Blue LEDs and Silicon Carbide Wafers

The ATP project has been highly productive for Cree and the economy at large. The company has used the new technology to produce larger silicon carbide wafers to use in its fabrication process for blue LEDs. It is also offering the larger silicon carbide wafers for sale to companies.

Cree is using the ATP-funded technology to reduce the cost of producing blue LEDs, and their sales have increased substantially. Production cost is primarily a function of the number of wafers processed. If wafer size can be increased dramatically, the cost per device will decrease dramatically because so many more devices can be produced on a wafer. The silicon carbide wafer technology is also aimed at markets for other blue light-emitting optoelectronic devices, optical disk storage, microwave communications, and blue and ultraviolet laser diodes, as well as high-temperature, high-power, and high-frequency semiconductors.

Benefits for the Economy

Benefits from the new silicon carbide technology are already accruing to customers who have bought large volumes of silicon carbide wafers to use in their own production. Performance measures (resistance, power output, sensitivity to light) for silicon carbide devices are frequently large, relative to available alternatives. Economic benefits from these performance improvements spill over to other producers involved in fabrication and assembly before a wafer-based product reaches the end user. The incremental benefits is expected to be much larger than the profits Cree receives for selling the silicon carbide wafers.

Cree's private success has led to public benefit, which is expected to grow as the number of applications for larger silicon carbide wafers increases. Westinghouse, for example, used Cree's silicon carbide wafers in fabricating components for the transmitter for the first commercial-level HDTV broadcast in the United States, in 1996. Westinghouse said its transmitter can deliver three times the life and costs less to produce than conventional silicon-based transmitters. Although the number of HDTV transmitters using silicon carbide wafers is unknown at this time, widespread use of this technology in HDTV broadcasting could produce significant economic benefits if it speeds commercialization of HDTV.

ATP Advantages

Cree reports it was attracted to the ATP as a funding source for the development of the bulk crystal and epitaxial growth technology because the company could retain its process technology knowledge. The ATP award also helped Cree form alliances with other companies, enabling the company to get results about 18 months sooner than it would otherwise have been able to do. D



IGBTs de silicon carbide

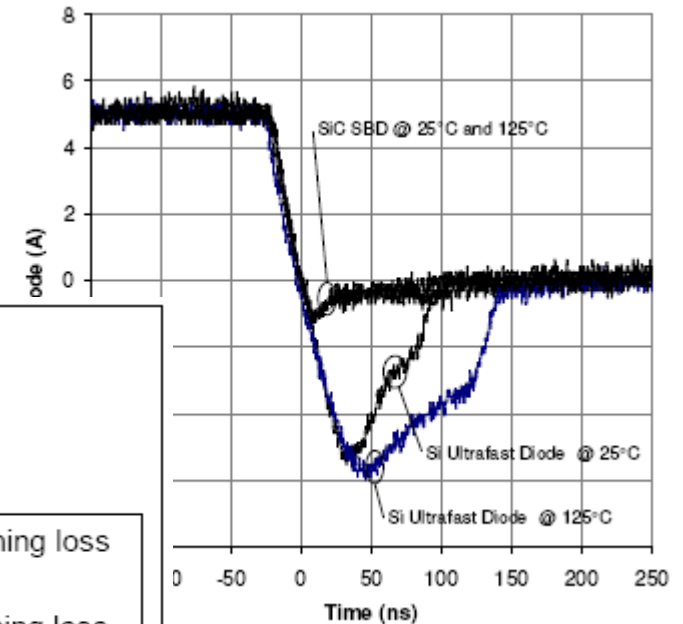
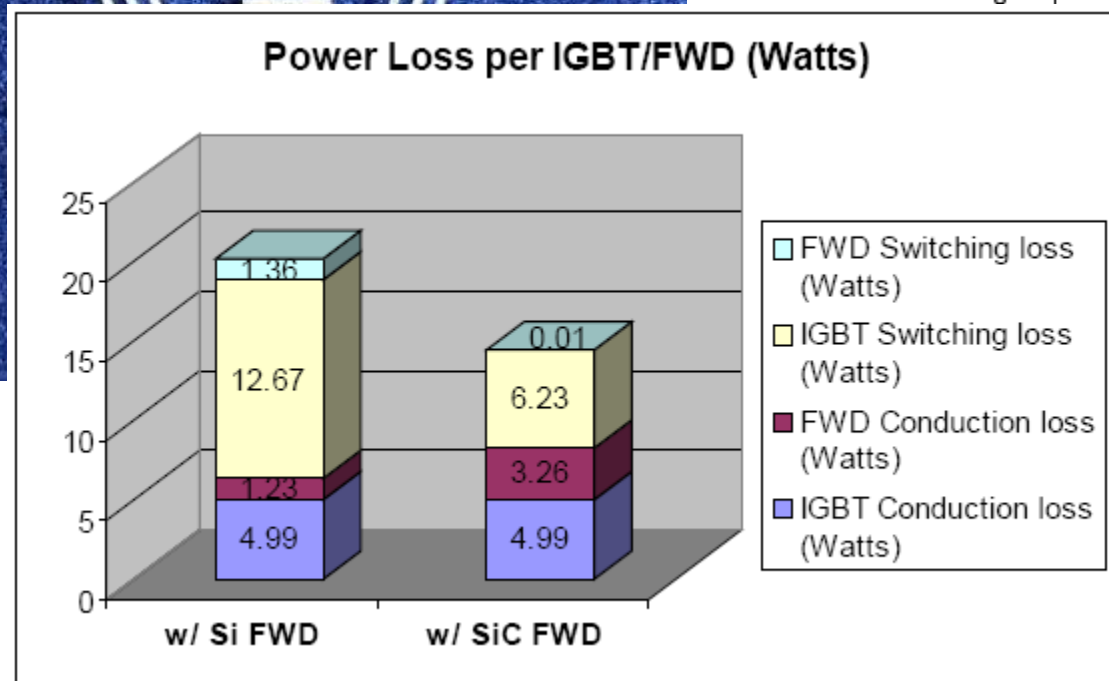

Na próxima aula

Seqüência de conteúdos:

1. Aplicações de diodos – Parte 1.

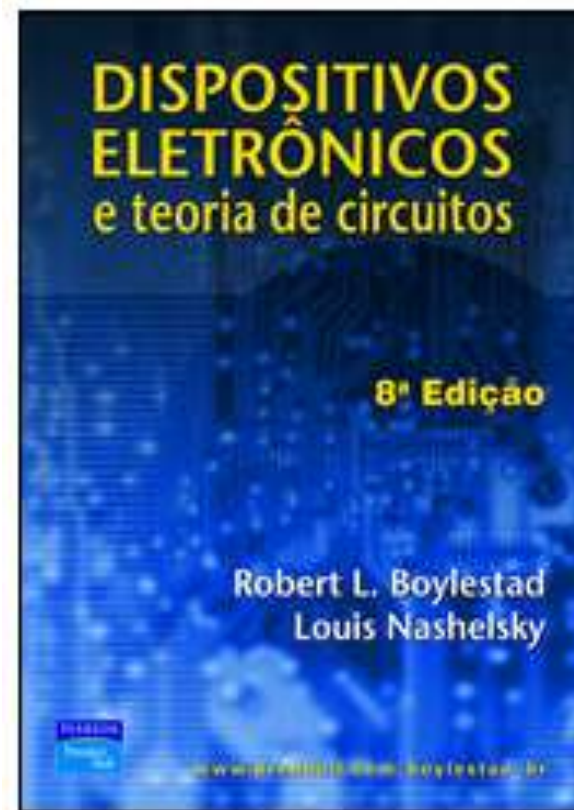

www.cefetsc.edu.br/~petry